

# Mitsubishi Package Air-Conditioner Optional Component

## Instructions on Installing Drain Socket

### SAFETY PRECAUTIONS

- Read these "Safety Precautions" thoroughly and install the drain socket securely.
- Be sure to observe the precautions given here: They are critical for safety.
- Precautions are classified using the following symbols depending on extent and type of danger by erroneous handling:

<b>WARNING</b>	Erroneous handling can cause death or serious injury.
<b>CAUTION</b>	Erroneous handling can cause personal injury or damage.

● After installation, make a trial run to ensure that no fault occurs, and ask the customer to keep this installation sheet with instruction manual. Also ask the customer to pass them to the new user if the user changes.

#### WARNING

<p><b>Ask the dealer or specialist to install the drain socket.</b></p> <ul style="list-style-type: none"> <li>● If the user install the drain socket incorrectly by yourself, some components could cause water leak, electric shock, fire, etc.</li> </ul>	<p><b>Securely install the drain socket, referring to this installation sheet.</b></p> <ul style="list-style-type: none"> <li>● Incomplete installation could cause water leak, electric shock, fire, etc., with some components.</li> </ul>
--	--

Before performing installation (moving) and electrical construction:

#### CAUTION

<p><b>Do not place polyethylene bags in reach of children.</b></p> <ul style="list-style-type: none"> <li>● Putting over the head will block breathing passages, which could result in suffocation.</li> </ul>	<p><b>If wiring for power supply is necessary, use only specified wires that comply with current capacity.</b></p> <ul style="list-style-type: none"> <li>● Using other wires could cause leak, heat generation, fire, etc.</li> </ul>
<p><b>If refrigerant piping is necessary, securely execute insulation so that condensation does not occur.</b></p> <ul style="list-style-type: none"> <li>● Incomplete insulation will cause condensation on surface of pipe, etc. and moisture will drip, which could wet ceiling, floor or other areas.</li> </ul>	<p><b>If drain piping is necessary, lay piping for secure drain, referring to instruction manual, and maintain the temperature to prevent condensation.</b></p> <ul style="list-style-type: none"> <li>● Incomplete piping will cause water leak, which could wet ceiling, floor or household goods.</li> </ul>

The outdoor unit is provided with several holes for drainage at the bottom to make drainage easier. The drain socket is used to close the unnecessary holes and centralize the drainage when using the drain tube at the installation place.  
Do not to use the drain socket in cold areas. The drain tube can be frozen.  
※ Condensation could drop through the part fitting holes and knockout holes (slits) in the bottom of the outdoor unit. Use the centralized drain pan to completely prevent condensation dropping.

### 1. Accessory

Be aware that the following parts are put in the package together with the instruction manual.

① Drain socket ..... 1 pc	② Drain cap Large size: 5pcs Small size: 2pcs ※The number of pieces changes depending on the model.
③ Insulation part (for liquid pipe) ..... 1 pc	④ Insulation part (for gas pipe) ..... 1 pc
⑤ Band ..... 8 pcs	

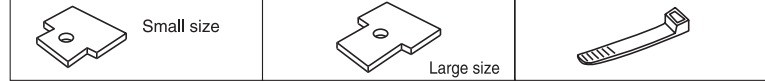

### 2. Installation method for drain unit ☆ Prepare the adhesive in the field.

- (1) Glue the drain socket ① to the hole that is used to centralize the drainage among several holes at the bottom of the unit with the glue (Prepare in the field).
- (2) Glue the drain caps ② to close all the other unnecessary holes with the glue (Prepare in the field). The number of holes changes depending on the model.  
 (Note) Apply the glue securely, as the glue (Prepare in the field) will work as seal to prevent water from leaking.  
 (Note) Use the adhesive for the rubber and metal.
- (3) Insert a vinyl tube of which inner diameter 25 mm available commercially or a hard vinyl tube VP25 to the drain socket ①.

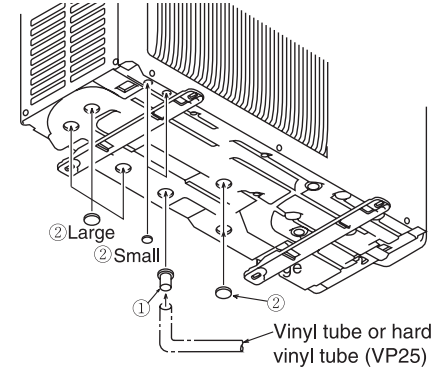
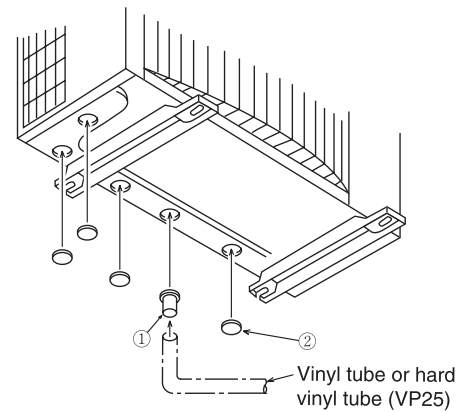

For outdoor unit with a dimension of 800x600x300 (widthxheightxdepth)

### 3. Installation method for insulation parts

- Install the insulation parts to stop valve of the outdoor unit.  
 ※ The insulation parts should be installed after the tube has been connected to the unit.  
 ※ Some units are provided with a check valve near stop valve. In this case, cut the insulation parts ③ and ④ so that they will fit the stop valve properly.
- (1) Install the insulation part ③ with 2 holes to the liquid pipe side so that the holes fit the valve caps and cover the stop valve entirely.
  - (2) Fix the insulation part ③ securely with bands ⑤.
- Install the other insulation part ④ to the gas pipe side with the same procedure.

• Cut the right and left ends of the insulation part ④ as appropriate as shown to the under.

