



Service Manual

Models:

GWH09AKC-K6DNA1A
GWH12AKC-K6DNA1A
GWH18AKC-K6DNA1A
(R32)

GREE ELECTRIC APPLIANCES, INC. OF ZHUHAI

The background features a network of thin grey lines connecting various circular nodes, some of which are shaded in light blue or grey. At the bottom, there are large, overlapping geometric shapes in shades of blue and teal. A portion of these shapes shows a detailed, metallic-looking structure of pipes and machinery, likely representing an air conditioning system's internal components.

Table of Contents

Part I : Technical Information	1
1. Summary	1
2. Specifications	2
2.1 Specification Sheet.....	2
2.2 Capacity Variation Ratio According to Temperature	6
2.3 Cooling and Heating Data Sheet in Rated Frequency.....	6
2.4 Noise Curve	7
3. Outline Dimension Diagram	8
3.1 Indoor Unit.....	8
3.2 Outdoor Unit.....	8
4. Refrigerant System Diagram	10
5. Electrical Part	11
5.1 Wiring Diagram	11
5.2 PCB Printed Diagram	13
6. Function and Control	17
6.1 Remote Controller Introduction	17
6.2 GREE+ App Operation Manual	21
6.3 Ewpe Smart App Operation Manual.....	22
6.4 Brief Description of Modes and Functions	23
Part II : Installation and Maintenance	28
7. Notes for Installation and Maintenance	28
8. Installation	32
8.1 Installation Dimension Diagram.....	32
8.2 Installation Parts-checking	34
8.3 Selection of Installation Location.....	34
8.4 Electric Connection Requirement	34
8.5 Installation of Indoor Unit.....	34

2. Specifications

2.1 Specification Sheet

Model			GWH09AKC-K6DNA1A	GWH12AKC-K6DNA1A
Product Code			CB340000100 CB340000101	CB340000200 CB340000201
Power Supply	Rated Voltage	V~	220-240	220-240
	Rated Frequency	Hz	50	50
	Phases		1	1
Power Supply Mode			Indoor	Indoor
Cooling Capacity		W	2700	3530
Heating Capacity		W	3600	4200
Cooling Power Input		W	550	802
Heating Power Input		W	750	934
Cooling Current Input		A	2.65	3.55
Heating Current Input		A	3.54	4.23
Rated Input		W	1600	1650
Rated Cooling Current		A	6.05	6.22
Rated Heating Current		A	7	7.5
Air Flow Volume(SS/H/MH/M/ML/L/SL/SM)		m ³ /h	700/600/530/500/400/300/270/180	800/700/550/500/400/300/270/180
Dehumidifying Volume		L/h	0.8	1.4
EER		W/W	4.91	4.4
COP		W/W	4.8	4.5
SEER		W/W	9.4	9
SCOP(Average/Warmer/Colder)		W/W	5.1/6.3/4	5.1/6.2/4
Application Area		m ²	12-18	16-24
Indoor Unit	Model		GWH09AKC-K6DNA1A/I	GWH12AKC-K6DNA1A/I
	Product Code		CB340N00100 CB340N00101	CB340N00200 CB340N00201
	Fan Type		Cross-flow	Cross-flow
	Fan Diameter Length(DXL)	mm	Φ120×650	Φ120×650
	Cooling Speed	r/min	1200/1050/950/900/750/600/550/450	1300/1100/1000/900/750/600/550/450
	Heating Speed	r/min	1200/1050/950/900/800/750/650	1300/1100/1000/900/800/750/650
	Fan Motor Power Output	W	20	20
	Fan Motor RLA	A	-	-
	Fan Motor Capacitor	μF	/	/
	Evaporator Form		Aluminum Fin-copper Tube	Aluminum Fin-copper Tube
	Evaporator Pipe Diameter	mm	Φ5	Φ5
	Evaporator Row-fin Gap	mm	4-1.4	4-1.4
	Evaporator Coil Length (LXD _X W)	mm	651×59.5×365	651×59.5×365
	Swing Motor Model		MP24AM/MP35CN /MP20AC	MP24AM/MP35CN /MP20AC
	Swing Motor Power Output	W	1.5/2.5/1.5	1.5/2.5/1.5
	Fuse Current	A	5	5
	Sound Pressure Level	dB (A)	Cooling:42/38/35/33/29/22/19/18 Heating:42/38/35/33/29/27/24	Cooling:44/39/37/34/29/23/22/20 Heating:44/39/37/34/29/27/25
	Sound Power Level	dB (A)	55	59
	Dimension (WXHXD)	mm	977X281X295	977X281X295
	Dimension of Carton Box (LXWXH)	mm	1083X373X387	1083X373X387
	Dimension of Package (LXWXH)	mm	1086X376X402	1086X376X402
	Net Weight	kg	17	17
	Gross Weight	kg	21.5	21.5

Outdoor Unit	Outdoor Unit Model		GWH09AKC-K6DNA1A/O	GWH12AKC-K6DNA1A/O
	Outdoor Unit Product Code		CB340W00100	CB340W00200
	Compressor Manufacturer		ZHUHAI LANDA COMPRESSOR CO., LTD	ZHUHAI LANDA COMPRESSOR CO., LTD
	Compressor Model		QXF-B103zF190A	QXF-B103zF190A
	Compressor Oil		FW68DA	FW68DA
	Compressor Type		Rotary	Rotary
	Compressor LRA	A	25	25
	Compressor RLA	A	4	4
	Compressor Power Input	W	800	800
	Compressor Overload Protector		HPC115/95U1/KSD115°C	HPC115/95U1/KSD115°C
	Throttling Method		Electron expansion valve	Electron expansion valve
	Set Temperature Range	°C	Cooling:16~30 Heating:8~30	Cooling:16~30 Heating:8~30
	Cooling Operation Ambient Temperature Range	°C	-15~52	-15~52
	Heating Operation Ambient Temperature Range	°C	-25~24	-25~24
	Condenser Form		Aluminum Fin-copper Tube	Aluminum Fin-copper Tube
	Condenser Pipe Diameter	mm	Φ7.94	Φ7.94
	Condenser Rows-fin Gap	mm	2.5-1.4	2.5-1.4
	Condenser Coil Length (LXDXW)	mm	733×57×550	733×57×550
	Fan Motor Speed	rpm	900	900
	Fan Motor Power Output	W	30	30
	Fan Motor RLA	A	0.37	0.37
	Fan Motor Capacitor	μF	/	/
	Outdoor Unit Air Flow Volume	m ³ /h	2400	2400
	Fan Type		Axial-flow	Axial-flow
	Fan Diameter	mm	438	438
	Defrosting Method		Automatic Defrosting	Automatic Defrosting
	Climate Type		T1	T1
	Isolation		I	I
	Moisture Protection		IPX4	IPX4
	Permissible Excessive Operating Pressure for the Discharge Side	MPa	4.3	4.3
	Permissible Excessive Operating Pressure for the Suction Side	MPa	2.5	2.5
	Sound Pressure Level (H/M/L)	dB (A)	53	54
	Sound Power Level (H/M/L)	dB (A)	62	62
Dimension(WXHXD)	mm	899X596X378	899X596X378	
Dimension of Carton Box (LXWXH)	mm	945X417X630	945X417X630	
Dimension of Package(LXWXH)	mm	948X420X645	948X420X645	
Net Weight	kg	37.5	37.5	
Gross Weight	kg	40.5	40.5	
Refrigerant		R32	R32	
Refrigerant Charge	kg	1	1	
Connection Pipe	Connection Pipe Length	m	5	5
	Connection Pipe Gas Additional Charge	g/m	16	16
	Outer Diameter Liquid Pipe		1/4"	1/4"
	Outer Diameter Gas Pipe		3/8"	3/8"
	Max Distance Height	m	10	10
	Max Distance Length	m	15	20
Note: The connection pipe applies metric diameter.				

The above data is subject to change without notice. Please refer to the nameplate of the unit.

Model			GWH18AKC-K6DNA1A	
Product Code			CB340000300	
Power Supply	Rated Voltage	V~	220-240	
	Rated Frequency	Hz	50	
	Phases		1	
Power Supply Mode			Outdoor	
Cooling Capacity		W	5300	
Heating Capacity		W	5600	
Cooling Power Input		W	1395	
Heating Power Input		W	1474	
Cooling Current Input		A	6.2	
Heating Current Input		A	6.6	
Rated Input		W	2450	
Rated Cooling Current		A	9.3	
Rated Heating Current		A	11	
Air Flow Volume(SS/H/MH/M/ML/L/SL/SM)		m ³ /h	800/700/550/500/450/350/300/250	
Dehumidifying Volume		L/h	1.8	
EER		W/W	3.8	
COP		W/W	3.8	
SEER		W/W	7	
SCOP(Average/Warmer/Colder)		W/W	4.3/4.9/3.4	
Application Area		m ²	21-31	
Indoor Unit	Model		GWH18AKC-K6DNA1A/I	
	Product Code		CB340N00300	
	Fan Type		Cross-flow	
	Fan Diameter Length(DXL)		mm	Φ120×650
	Cooling Speed		r/min	1300/1100/1000/900/800/650/600/550
	Heating Speed		r/min	1350/1200/1050/950/900/800/750
	Fan Motor Power Output		W	20
	Fan Motor RLA		A	-
	Fan Motor Capacitor		μF	/
	Evaporator Form			Aluminum Fin-copper Tube
	Evaporator Pipe Diameter		mm	Φ5
	Evaporator Row-fin Gap		mm	4-1.4
	Evaporator Coil Length (LXDXW)		mm	651×59.5×365
	Swing Motor Model			MP24AM MP35CN MP20AC
	Swing Motor Power Output		W	1.5/2.5/1.5
	Fuse Current		A	5
	Sound Pressure Level		dB (A)	Cooling:46/40/37/35/31/25/24/22 Heating:46/41/38/34/32/29/28
	Sound Power Level		dB (A)	Cooling:60/54/51/49/45/39/38 Heating:60/55/52/48/46/43/42
	Dimension (WXHxD)		mm	977X281X295
	Dimension of Carton Box (LXWXH)		mm	1083X373X387
Dimension of Package (LXWXH)		mm	1090X380X407	
Net Weight		kg	17	
Gross Weight		kg	21.5	

2.2 Capacity Variation Ratio According to Temperature

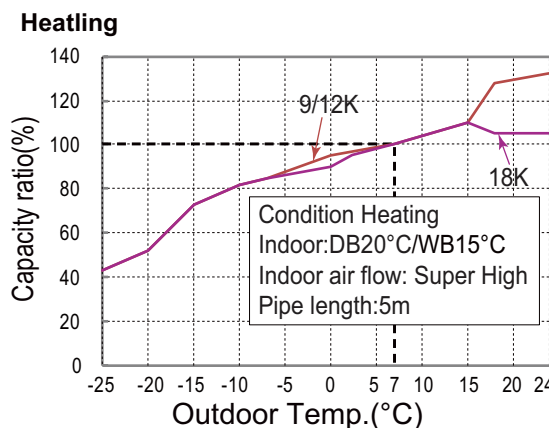
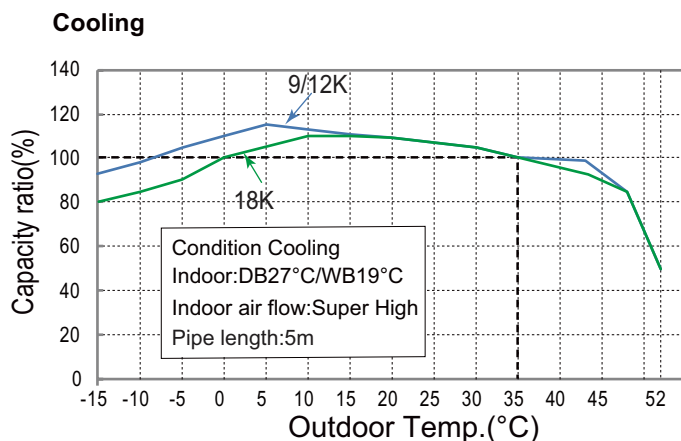

2.3 Cooling and Heating Data Sheet in Rated Frequency

Cooling:

Rated cooling condition(°C) (DB/WB)		Model	Pressure of gas pipe connecting indoor and outdoor unit	Inlet and outlet pipe temperature of heat exchanger		Fan speed of indoor unit	Fan speed of outdoor unit
Indoor	Outdoor			T1 (°C)	T2 (°C)		
27/19	35/24	ALL	P (MPa) 0.9 to 1.1	12 to 14	75 to 37	Super High	High

Heating:

Rated cooling condition(°C) (DB/WB)		Model	Pressure of gas pipe connecting indoor and outdoor unit	Inlet and outlet pipe temperature of heat exchanger		Fan speed of indoor unit	Fan speed of outdoor unit
Indoor	Outdoor			T1 (°C)	T2 (°C)		
20/-	7/6	ALL	2.8 to 3.0	70 to 35	2 to 4	Super High	High

Instruction:

T1: Inlet and outlet pipe temperature of evaporator

T2: Inlet and outlet pipe temperature of condenser

P: Pressure at the side of big valve

Connection pipe length: 5m.

3. Outline Dimension Diagram

3.1 Indoor Unit

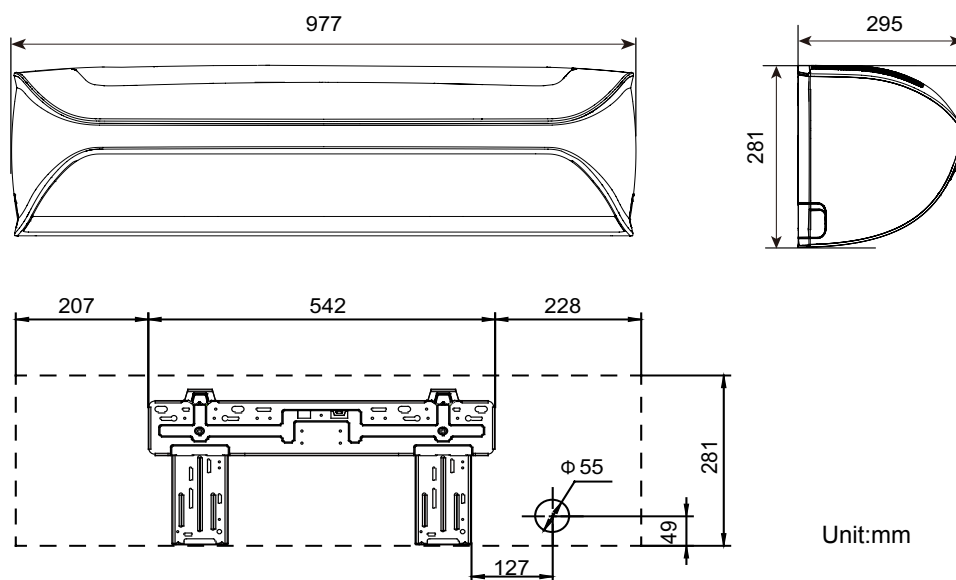

3.2 Outdoor Unit

9/12K

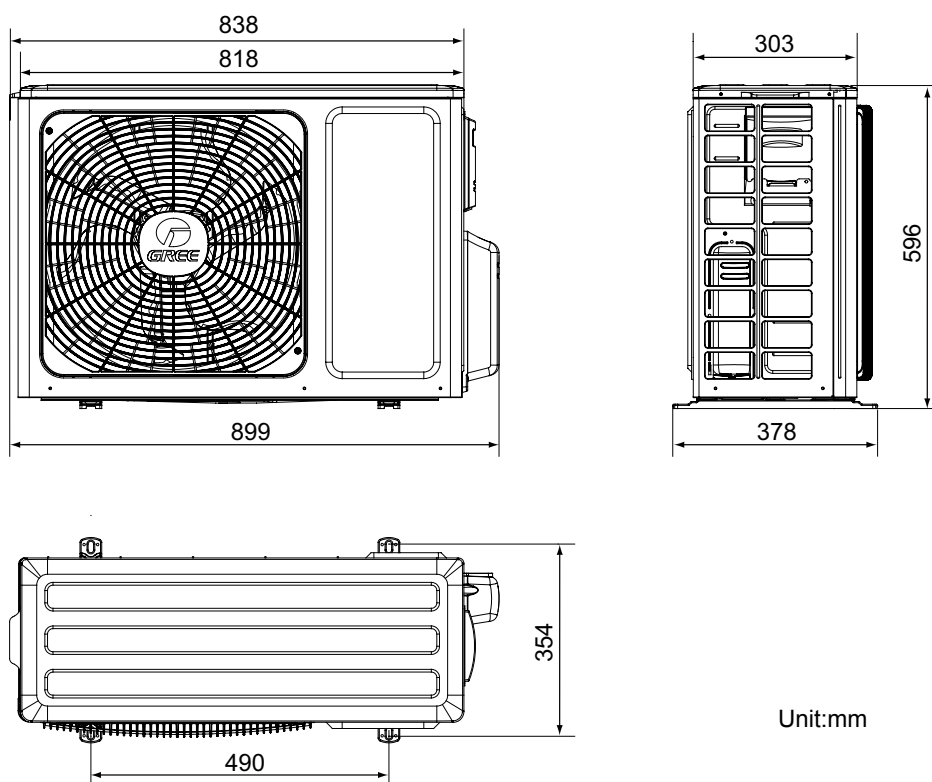

5.2 PCB Printed Diagram

Indoor Main PCB

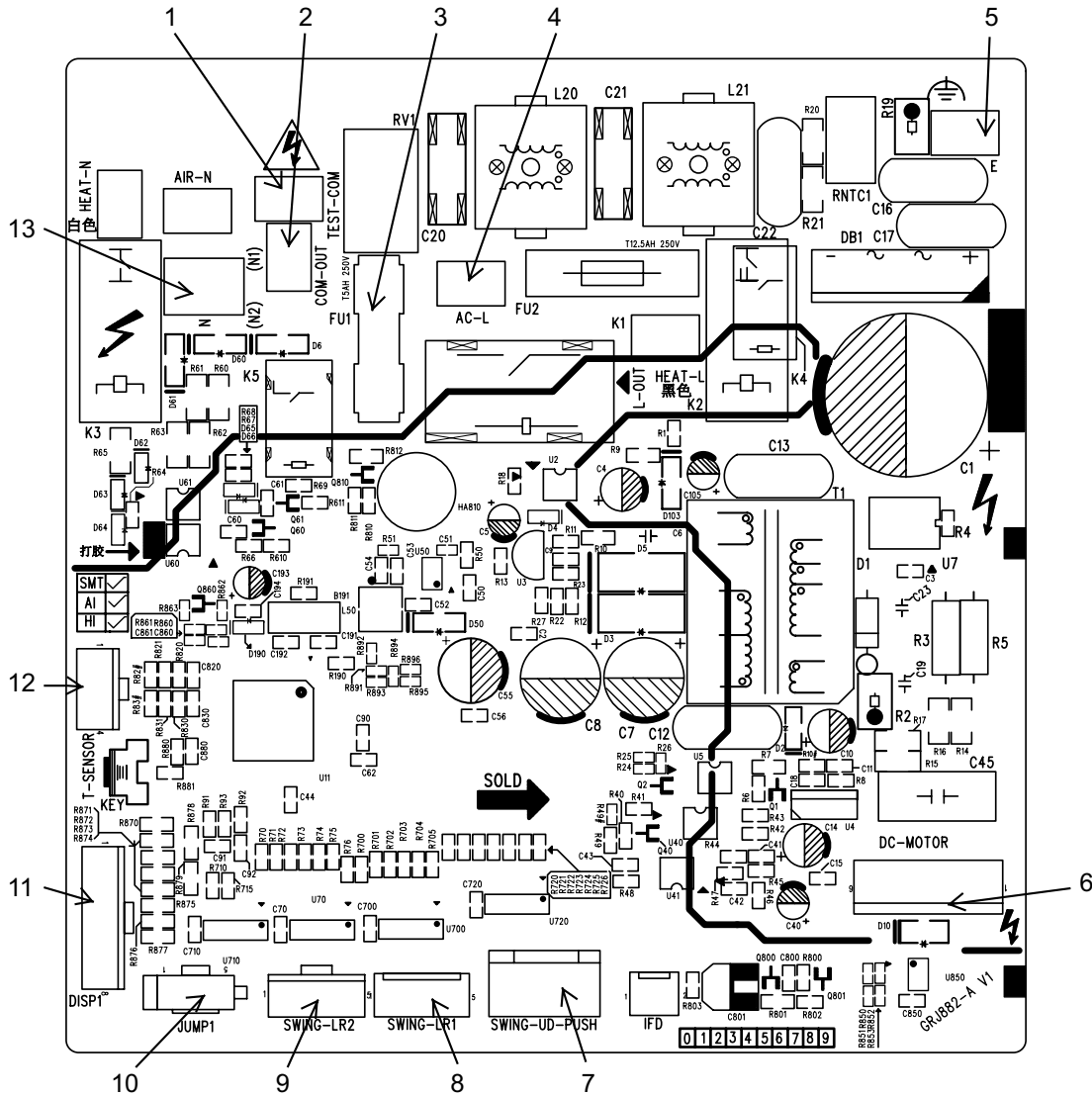

No.	Name
1	Communication interface of service self-detection device
2	Communication terminal of indoor unit and outdoor unit
3	Fuse
4	Live wire terminal
5	Grounding wire interface
6	DC motor terminal
7	Up&down swing and out-pushing mechanism
8	Up&down swing 1
9	Up&down swing 2
10	Jumper cap
11	Display board interface
12	Temperature sensor terminal
13	Neutral wire terminal

Display PCB

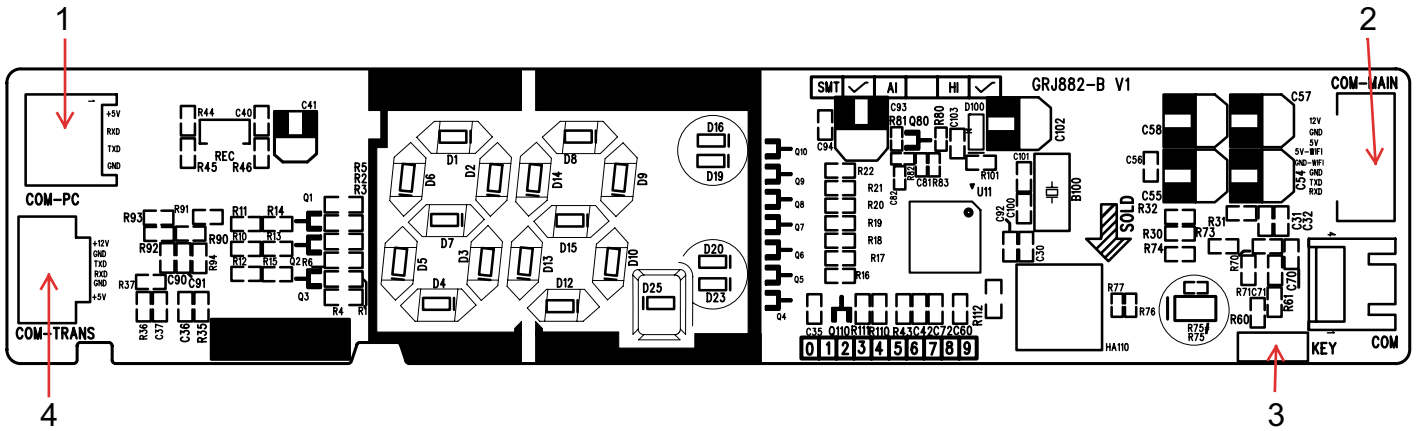

No.	Name
1	WIFI detection interface
2	Main board interface
3	Auto button
4	Connection board interface

Connection PCB

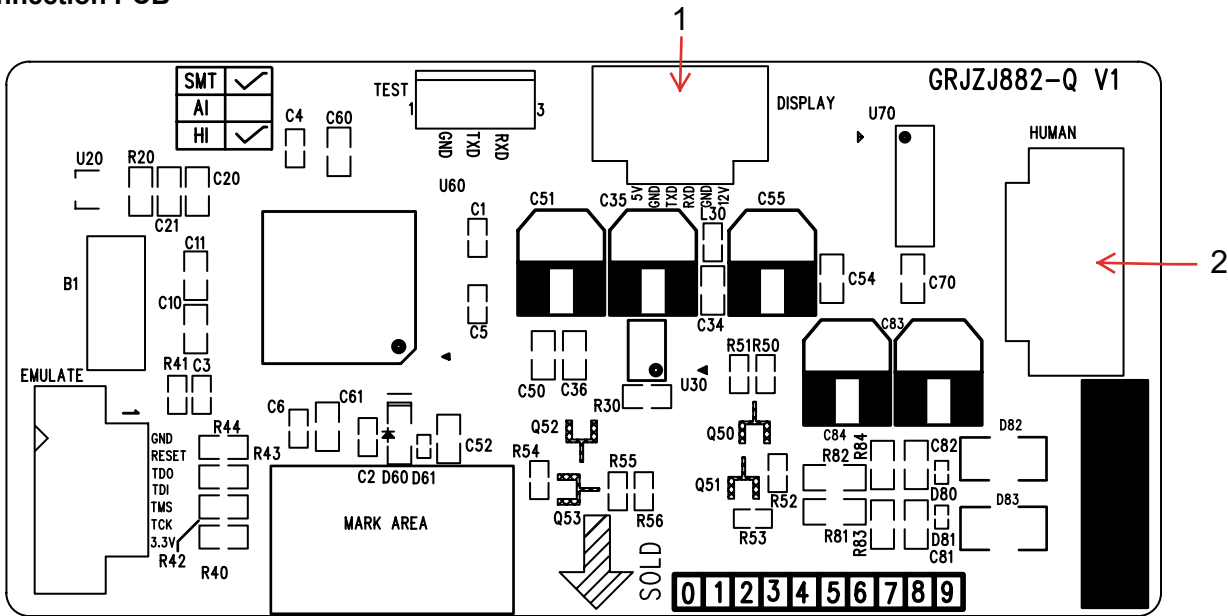

No.	Name
1	Display board interface
2	Human body induction meter interface

Human induction meter PCB

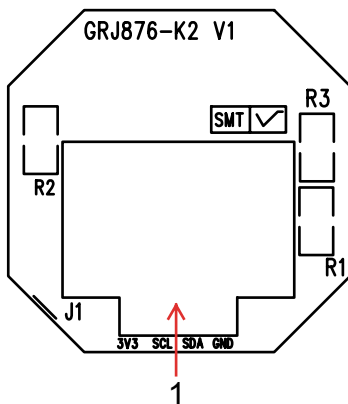

No.	Name
1	Connection board interface

Note:

- This series has no health and breeze functions.

1.ON/OFF

Press this button to turn on/off the air conditioner. When turning on/off, clear off the original timer and sleep setting.

2.MODE

Press this button to select your required operation mode.



Note: cooling only type does not receive heating mode signa.

3.-/+



Press "-" or "+" button once increase or decrease set temperature 0.5 °C.

Holding "-" or "+" button, 1s later, set temperature on remote controller will change quickly. On releasing button after setting is finished, temperature indicator on indoor unit will change accordingly.

4.FAN

Press this button, circulation change of fan speed is as follow: 

Under dry mode, it can only be operated under the fan speed of .

 can only be started under cooling and heating mode.  can be started under cooling and heating mode. Under fan mode, health function (this model has no health function) shall be started at the same time.

Under cooling mode, start the breeze function, circulation change of fan speed is as follow: 

5. SWING

Press this button to start (display “” icon) or shut down (no display “” icon) up and down swing function.

Remark: according to the comfort demand of air supply, the swing range under different modes is different.

6.U&D FIXED ANGLE

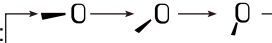
Press this button to set up and down swing status, the circula-tion change is as follow: 

7. SWING

Press this button to start (display “” icon) or shut down (no display “” icon) left and right swing function.

Remark: according to the comfort demand of air supply, the swing range under different modes is different.

8.L&R FIXED ANGLE

Press this button to set left and right swing status, the circulation change is as follow:



9.COOL

Press this button, the air conditioner will conduct cooling mode.

10.HEAT

Press this button, the air conditioner will conduct heating mode.

11. I SENSE

In Cool or Heat mode, press this button and the unit will work in the following sequence:



SMART: the unit will judge based on the body sensing device, body temperature, indoor temperature and the operation data to enter different air supply modes including airflow blowing to people, airflow avoiding people, and circular airflow.

FOLLOW: the unit will control the vertical and horizontal swing louvers automatically according to the body sensing device so as to blow air toward people.

AVOID: the unit will control the vertical and horizontal swing louvers automatically according to the body sensing device so as to avoid direct airflow to people.

SURROUND: the unit will control the vertical and horizontal swing louvers automatically according to the body sensing device so as to supply air around the people. If the air is directly blown to people, it will pass the people very quickly.

12.E-HEATER

Under heating mode, press this button, circulation change of auxiliary heating status is as follow:

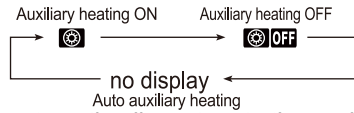

After starting heating mode, the remote controller will automatically restore to the auxiliary heating status set previously. The function is only available for some models.

13.TIMER

Under ON status, press this button to set timer OFF;

Under OFF status, press this button to set timer ON.

Press this button once and the characters of HOUR ON (OFF) will flash to be displayed. Mean-while, press "+" or "-" button to adjust timer setting (time will change quickly if holding "+" or "-" button). Timer setting range is 0.5~24hours. Press this button again to confirm timer setting and the characters of HOUR ON (OFF)will stop flash-ing.

If the characters are flashing but you haven't press timer button,timer setting status will be quit after 5s. If timer is confirmer, press this button again to cancel timer.

14.LIGHT

Press this button to control the LED status on the displayer, the circulation change is as follow:

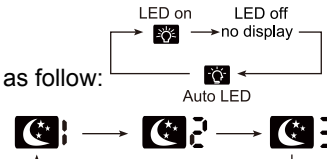

15.SLEEP

Press this button, the sleeping status will be circulated in the following sequence: Turn off sleep → Sleep 1 → Sleep 2 → Sleep 3 → Sleep 4 → Turn off sleep. **Sleep 1: Cooling mode:** under sleep status and after operation for 1h, the temperature of the master unit will increase 1°C, then 2°C after 2h, after that, the unit will be operated at the set temperature. **Heating mode:** under sleep status and after operation for 1h, the set temperature will decrease, then decrease 2°C after 2h, after that, the unit will be operated at the set temperature.

Sleep 2 is the sleep temperature curve preset based on the system.

Sleep 3 is the sleep curve setting under DIY sleep mode:

(1) Under Sleep 3 mode, long press "Up and down" button to enter personalized sleep setting status, as the fig shown:

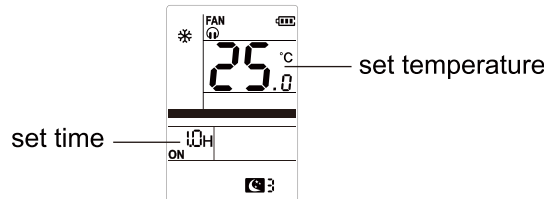

(2) Adjust "-" or "+" button to change the corresponding set temperature, after that, press "U&D FIXED ANGLE" button for confirmation to set temperature for the next hour, until temperature setting for the next 8h is finished. If sleep curve setting is completed, at this time, the remote controller will display again.

(3) If not pressing any buttons in 10 seconds, the remote controller will exit sleep curve setting status automatically and restore the original display. During setting process, if pressing "ON/OFF", "Timer", "Sleep" or other modes, it will exit the sleep curve setting as well.

Sleep 4 is the afternoon nap mode. The temperature will be changed automatically according to afternoon nap status.

If re-energizing the unit after power off, sleep mode will be cancelled acquiescently; if micro sense function is not activated, when starting the sleep function, quiet fan speed will be started automatically.

16.WiFi

When WiFi function is turned on, " WiFi " icon will be displayed on the remote controller; when WiFi function is turned off, " WiFi " icon will disappear.

How to turn on WiFi: Press " WiFi " button to turn on WiFi function.

How to turn off WiFi:Hold " WiFi " button for 5s to turn off WiFi function.

Under off status, press "MODE" and " WiFi " buttons simultaneously for 1s, WiFi module will restore factory settings.

This function is only available for some models.

17.MODE+FAN(Auto clean function)

When the remote controller is OFF, press "MODE" and "FAN" button at the same time for about 5 seconds to start auto clean function, after that, the air conditioner will display "CL". Repeat the operation to exit auto clean (if exiting auto clean through button operation, the unit will be operated in low speed for drying for a period of time compulsorily).

Operation time for cleaning is about 30 minutes.

NOTICE:

Don't mix the new battery with the old one and batteries of different types shall not be mixed. The remote controller shall be kept well;

Liquid shall not flow into the remote controller;

The remote controller shall avoid direct sunshine or not be put in places with high temperature.

If not using the remote controller for a long time, please take out the battery.

When the remote controller is sending message, “” icon will blink for about 1 second. When receiving 1 second. When receiving effective remote message, the air conditioner will give out a sound.

1. Press the back side of remote controller marked with “”, as shown in the fig, and then push out the cover of battery box along the arrow direction.
2. Replace two 7# (AAA 1.5V) dry batteries, and make sure the position of “+” polar and “-” polar are correct.
3. Reinstall the cover of battery box.

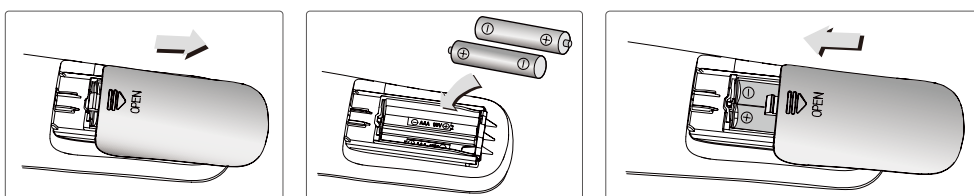

Remark: the remote controller will display the remaining battery life, when it displays “”, please replace the battery immediately.

Emergency operation

If remote controller is lost or damaged, please use aux. button to turn on or turn off the air conditioner. The operation in details is as below:

As shown, open the panel and press aux. button to turn on or turn off the air conditioner. When the air conditioner is turned on, it will operate under auto mode.

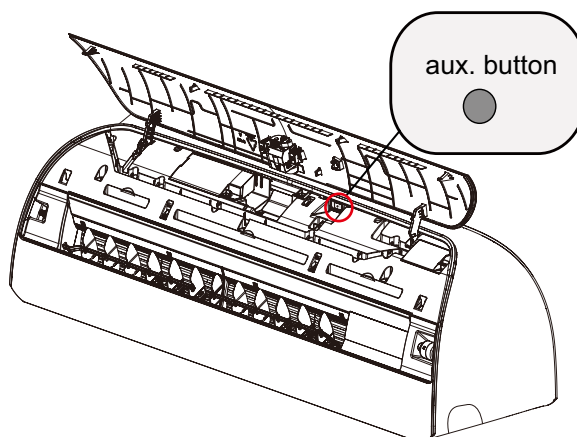

6.3 Ewpe Smart App Operation Manual

Control Flow Chart

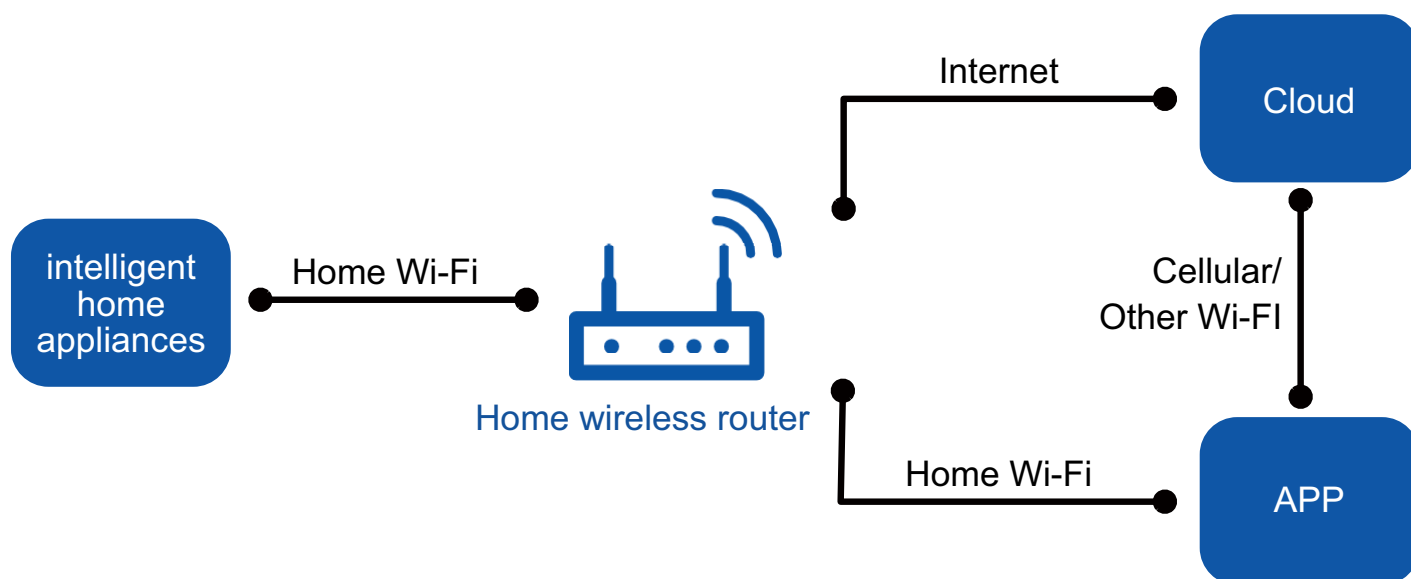

Operating Systems

Requirement for User's smart phone:

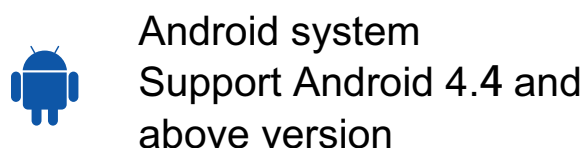
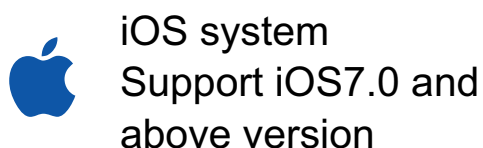

Download and installation



App Download Linkage

Scan the QR code or search "Ewpe Smart" in the application market to download and install it. When "Ewpe Smart" App is installed, register the account and add the device to achieve long-distance control and LAN control of smart home appliances. For more information, please refer to "Help" in App.

a beep.

(4) Sleep function:

Under this mode, the unit will operate in suitable sleep curve according to different set temperature.

(5) Turbo function:

This function can be set in cooling or heating mode.

(6) Auto fan speed control:

Under this mode, IDU fan will automatically operate in five fan speeds of high, medium high, medium, medium low and low according to the changes of ambient temperature.

(7) Left&right swing control:

Select different left&right swing directions according to the left&right swing remote control status.

Position ①, position ②, position ③, position ④, position ⑤, left&right swing from position ① ~ ⑤, stop position, position ① ⑤, confronted swing.

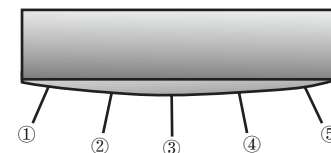

(8) Up&down swing control:

Up&down swing consists of two parts: swing mechanism and swing louvers;

After energizing, swing mechanism will arrange reset action and then extend to the maximum angle before closing;

After turning on the unit, the mechanism will extend to different length according to the remote control status. The swing louvers has two kinds of situation in the view of position: upper part swing and lower part swing;

If fixed-angle swing is selected, three different position swing for air supply can be selected;

If unrestricted swing is selected, the unit will arrange lower part swing during heating and arrange upper part swing during cooling;

For detailed position, please refer to the following figure:

Diagram of swing louver position

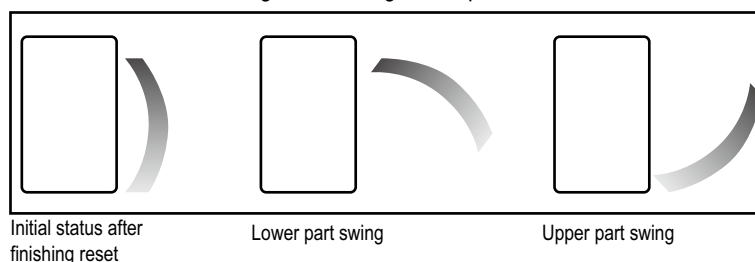

(9) Display

After energizing, the nixie tube and power indicator are all on. Under standby status, power indicator is on. When turning on the unit with remote control, the nixie tube displays current set temperature. If light button is turned off, all displays are off too.

6. Special functions

Photoconductive sound and light control

When "auto light" is set by the remote control, the unit will enter photoconductive sound and light control if the indoor controller detects that the brightness is low. In this case, nixie tube and power indicator display is off. When remote control brightness will be lower and the sound of buzzer will be lower, too. After 5s, the display will be off again.

I Sense control

1. For the model with I Sense detection device

1.1 Smart sensing swing function:

Under cooling or heating mode, you can set "Smart", "Follow", "Avoid" or "Surround" sensing swing function through the remote control or corresponding APP. I Sense device automatically starts detection. The air conditioner automatically detects human sensing temperature and quickly enters comfortable sensing status. The air conditioner automatically controls temperature, angle of horizontal louver and swing angle.

- Smart: according to human sensing device detection, human sensing temperature, indoor temperature and unit operation parameter, it automatically judge and select to enter comfortable air supply mode, such as Follow, Avoid or Surround.
- Follow: according to human sensing device, it automatically controls up&down swing, left&right swing to supply comfortable air to the position where people stay.
- Avoid: according to human sensing device, it automatically controls up&down swing, left&right swing to supply comfortable air to avoid the position where people stay.
- Surround: according to human sensing device, it automatically controls up&down swing, left&right swing to supply comfortable air to the surrounding where people stay. When the air reaches the position when people stay, it will pass through quickly.

1.2 Nobody energy-saving function

After setting nobody energy-saving function with mobile APP, I Sense device automatically starts detection. When it detects that nobody in the room, the unit will enter energy-saving operation automatically. The I Sense device will start body heat source detection. According to the status detected by the I Sense device, if nobody is detected in a certain time and the conditions for entering nobody energy-saving mode are met, the unit will automatically arrange necessary temperature adjustment to achieve

● Outdoor Unit

1. Cooling mode:

Working condition and process of cooling mode:

- ① When Tindoor ambient temperature $\geq T_{\text{preset}}$, unit enters into cooling mode. Indoor fan, outdoor fan and compressor start operation. Indoor fan operates according to set fan speed.
- ② When Tindoor ambient temperature $\leq T_{\text{preset}} - 2^{\circ}\text{C}$, compressor stops operation and outdoor fan will stop 30s later. Indoor fan operates according to set fan speed.
- ③ When $T_{\text{preset}} - 2^{\circ}\text{C} < \text{Tindoor ambient temperature} < T_{\text{preset}}$, unit operates according to the previous status.

Under cooling mode, 4-way valve is not energized. Temperature setting range is $16\sim 30^{\circ}\text{C}$. If compressor stops because of malfunction in cooling mode, indoor fan and swing motor will work according to the original status.

2. Drying mode

(1) Working condition and process of drying mode

- ① When Tindoor ambient temperature $> T_{\text{preset}}$, unit will be in drying mode. Outdoor fan and compressor start operation while indoor fan will operate at low fan speed.
- ② When $T_{\text{preset}} - 2^{\circ}\text{C} \leq \text{Tindoor ambient temperature} \leq T_{\text{preset}}$, unit operates according to the previous status.
- ③ When Tindoor ambient temperature $< T_{\text{preset}} - 2^{\circ}\text{C}$, compressor stops operation and outdoor fan will stop 30s later.

(2) Under drying mode, 4-way valve is not energized. Temperature setting range is $16\sim 30^{\circ}\text{C}$.

(3) Protection function: same as in cooling mode.

3. Fan mode

(1) Under this mode, indoor fan can select different fan speed (except Turbo) or auto fan speed. Compressor, outdoor fan and 4-way valve all stop operation.

(2) In fan mode, temperature setting range is $16\sim 30^{\circ}\text{C}$.

4. Heating mode

Working condition and process of heating mode:

- ① When $T_{\text{preset}} - (\text{Tindoor ambient temperature} - T_{\text{compensation}}) \geq 1^{\circ}\text{C}$, unit enters into heating mode. Compressor, outdoor fan and 4-way valve start operation.
- ② When $-2^{\circ}\text{C} < T_{\text{preset}} - (\text{Tindoor ambient temperature} - T_{\text{compensation}}) < 1^{\circ}\text{C}$, unit operates according to the previous status.
- ③ When $T_{\text{preset}} - (\text{Tindoor ambient temperature} - T_{\text{compensation}}) \leq -2^{\circ}\text{C}$, compressor stops operation and outdoor fan will stop 30s later. Indoor fan will be in residual-heat blowing status.
- ④ When unit is turned off under heating mode or changed to other modes from heating mode, 4-way valve will be power-off 2min after compressor stops working (compressor is in operation status under heating mode).
- ⑤ When Tindoor ambient temperature $> 30^{\circ}\text{C}$, compressor stops operation immediately. Outdoor fan will stop 30s later.
- ⑥ Under the condition that compressor is turned on, when unit is changed to heating mode from cooling or drying mode, 4-way valve will be energized in 2~3mins delay.

Note: Tcompensation is determined by IDU and ODU. If IDU controls the compensation temperature, then Tcompensation is determined according to the value sent by IDU to ODU; If IDU does not control the compensation temperature, then Tcompensation will default to 3°C by the ODU.

5. Freon recovery mode

After the Freon recovery signal from IDU is received, cooling at rated frequency will be forcibly turned on to recover Freon.

Indoor unit will display Fo. If any signal from remote controller is received, unit will exit from Freon recovery mode and indoor unit stops displaying Fo.

6. Compulsory defrosting

If unit is turned on under heating mode and set temperature is 16°C (by remote controller), press "+, -, +, -, +, -" within 5s, unit will enter into compulsory defrosting mode and send the signal to ODU. When the compulsory defrosting signal from ODU is received, IDU will exit from the compulsory defrosting mode and stop sending the signal to ODU.

After ODU receives the compulsory defrosting code, it will start compulsory defrosting. Defrosting frequency and opening angle will be the same as in normal defrosting mode. When compulsory defrosting is finished, the complete unit resumes original status.

Part II : Installation and Maintenance

7. Notes for Installation and Maintenance

Safety Precautions: Important!

Please read the safety precautions carefully before installation and maintenance.

The following contents are very important for installation and maintenance.

Please follow the instructions below.

- The installation or maintenance must accord with the instructions.
- Comply with all national electrical codes and local electrical codes.
- Pay attention to the warnings and cautions in this manual.
- All installation and maintenance shall be performed by distributor or qualified person.
- All electric work must be performed by a licensed technician according to local regulations and the instructions given in this manual.
- Be caution during installation and maintenance. Prohibit incorrect operation to prevent electric shock, casualty and other accidents.



Warnings

Electrical Safety Precautions:

1. Cut off the power supply of air conditioner before checking and maintenance.
2. The air condition must apply specialized circuit and prohibit share the same circuit with other appliances.
3. The air conditioner should be installed in suitable location and ensure the power plug is touchable.
4. Make sure each wiring terminal is connected firmly during installation and maintenance.
5. Have the unit adequately grounded. The grounding wire can't be used for other purposes.
6. Must apply protective accessories such as protective boards, cable-cross loop and wire clip.
7. The live wire, neutral wire and grounding wire of power supply must be corresponding to the live wire, neutral wire and grounding wire of the air conditioner.
8. The power cord and power connection wires can't be pressed by hard objects.
9. If power cord or connection wire is broken, it must be replaced by a qualified person.

10. If the power cord or connection wire is not long enough, please get the specialized power cord or connection wire from the manufacture or distributor. Prohibit prolong the wire by yourself.

11. For the air conditioner without plug, an air switch must be installed in the circuit. The air switch should be all-pole parting and the contact parting distance should be more than 3mm.

12. Make sure all wires and pipes are connected properly and the valves are opened before energizing.

13. Check if there is electric leakage on the unit body. If yes, please eliminate the electric leakage.

14. Replace the fuse with a new one of the same specification if it is burnt down; don't replace it with a cooper wire or conducting wire.

15. If the unit is to be installed in a humid place, the circuit breaker must be installed.

Installation Safety Precautions:

1. Select the installation location according to the requirement of this manual.(See the requirements in installation part)
2. Handle unit transportation with care; the unit should not be carried by only one person if it is more than 20kg.
3. When installing the indoor unit and outdoor unit, a sufficient fixing bolt must be installed; make sure the installation support is firm.
4. Ware safety belt if the height of working is above 2m.
5. Use equipped components or appointed components during installation.
6. Make sure no foreign objects are left in the unit after finishing installation.

Refrigerant Safety Precautions:

1. When refrigerant leaks or requires discharge during installation, maintenance, or disassembly, it should be handled by certified professionals or otherwise in compliance with local laws and regulations.
- 2.Avoid contact between refrigerant and fire as it generates poisonous gas; Prohibit prolong the connection pipe by welding.
3. Apply specified refrigerant only. Never have it mixed with any other refrigerant. Never have air remain in the refrigerant line as it may lead to rupture or other hazards.
4. Make sure no refrigerant gas is leaking out when installation is completed.
5. If there is refrigerant leakage, please take sufficient measure to minimize the density of refrigerant.
6. Never touch the refrigerant piping or compressor without wearing glove to avoid scald or frostbite.

Improper installation may lead to fire hazard, explosion, electric shock or injury.

Safety Operation of Flammable Refrigerant

Qualification requirement for installation and maintenance man

- All the work men who are engaging in the refrigeration system should bear the valid certification awarded by the authoritative organization and the qualification for dealing with the refrigeration system recognized by this industry. If it needs other technician to maintain and repair the appliance, they should be supervised by the person who bears the qualification for using the flammable refrigerant.
- It can only be repaired by the method suggested by the equipments manufacturer.

Installation notes

- The air conditioner is not allowed to use in a room that has running fire (such as fire source, working coal gas ware, operating heater).
- It is not allowed to drill hole or burn the connection pipe.
- The air conditioner must be installed in a room that is larger than the minimum room area. The minimum room area is shown on the nameplate or following table a.
- Leak test is a must after installation.

table a - Minimum room area(m²)

Minimum room area(m ²)	Charge amount (kg)	≤1.2	1.3	1.4	1.5	1.6	1.7	1.8	1.9	2	2.1	2.2	2.3	2.4	2.5
	wall mounted	/	1.6	1.9	2.1	2.4	2.8	3.1	3.4	3.8	4.2	4.6	5	5.5	6

Maintenance notes

- Check whether the maintenance area or the room area meet the requirement of the nameplate.
 - Its only allowed to be operated in the rooms that meet the requirement of the nameplate.
- Check whether the maintenance area is well-ventilated.
 - The continuous ventilation status should be kept during the operation process.
- Check whether there is fire source or potential fire source in the maintenance area.
 - The naked flame is prohibited in the maintenance area; and the “no smoking” warning board should be hanged.
- Check whether the appliance mark is in good condition.
 - Replace the vague or damaged warning mark.

Welding

- If you should cut or weld the refrigerant system pipes in the process of maintaining, please follow the steps as below:
 - a. Shut down the unit and cut power supply
 - b. Eliminate the refrigerant
 - c. Vacuuming
 - d. Clean it with N₂ gas
 - e. Cutting or welding
 - f. Carry back to the service spot for welding
- Make sure that there isnt any naked flame near the outlet of the vacuum pump and its well-ventilated.
- The refrigerant should be recycled into the specialized storage tank.

Filling the refrigerant

- Use the refrigerant filling appliances specialized for R32. Make sure that different kinds of refrigerant won't contaminate with each other.
- The refrigerant tank should be kept upright at the time of filling refrigerant.
- Stick the label on the system after filling is finished (or have not finished).
- Dont overfilling.
- After filling is finished, please do the leakage detection before test running; another time of leak detection should be done when its removed.

Safety instructions for transportation and storage

- Please use the flammable gas detector to check before unload and open the container.
- No fire source and smoking.
- According to the local rules and laws.

8. Installation

8.1 Installation Dimension Diagram

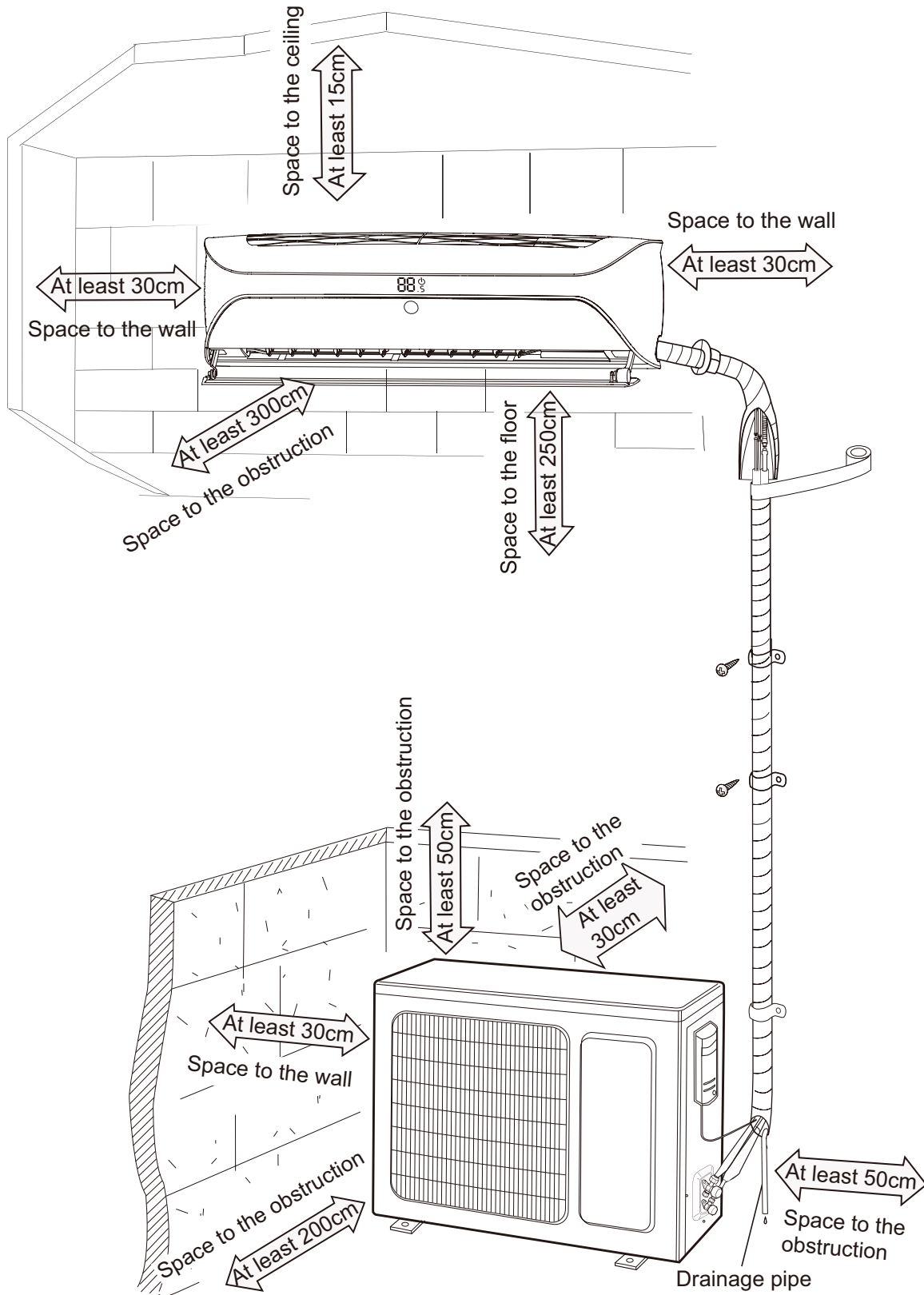

8.2 Installation Parts-checking

No.	Name	No.	Name
1	Indoor unit	8	Sealing gum
2	Outdoor unit	9	Wrapping tape
3	Connection pipe	10	Support of outdoor unit
4	Drainage pipe	11	Fixing screw
5	Wall-mounting frame	12	Drainage plug(cooling and heating unit)
6	Connecting cable(power cord)	13	Owners manual, remote controller
7	Wall pipe		

⚠ Note:

- 1.Please contact the local agent for installation.
- 2.Dont use unqualified power cord.

8.3 Selection of Installation Location

1. Basic Requirement:

Installing the unit in the following places may cause malfunction. If it is unavoidable, please consult the local dealer:

- (1) The place with strong heat sources, vapors, flammable or explosive gas, or volatile objects spread in the air.
- (2) The place with high-frequency devices (such as welding machine, medical equipment).
- (3) The place near coast area.
- (4) The place with oil or fumes in the air.
- (5) The place with sulfured gas.
- (6) Other places with special circumstances.
- (7) The appliance shall not be installed in the laundry.
- (8) It's not allowed to be installed on the unstable or motive base structure(such as truck) or in the corrosive environment (such as chemical factory).

2. Indoor Unit:

- (1) There should be no obstruction near air inlet and air outlet.
- (2) Select a location where the condensation water can be dispersed easily and won't affect other people.
- (3) Select a location which is convenient to connect the outdoor unit and near the power socket.
- (4) Select a location which is out of reach for children.
- (5) The location should be able to withstand the weight of indoor unit and won't increase noise and vibration.
- (6) The appliance must be installed 2.5m above floor.
- (7) don't install the indoor unit right above the electric appliance.
- (8) Please try your best to keep way from fluorescent lamp.

3. Outdoor Unit:

- (1) Select a location where the noise and outflow air emitted by the outdoor unit will not affect neighborhood.
- (2) The location should be well ventilated and dry, in which the outdoor unit won't be exposed directly to sunlight or strong wind.
- (3) The location should be able to withstand the weight of outdoor unit.
- (4) Make sure that the installation follows the requirement of installation dimension diagram.
- (5) Select a location which is out of reach for children and far away from animals or plants.If it is unavoidable, please add fence for safety purpose.

8.4 Electric Connection Requirement

1. Safety Precaution

- (1) Must follow the electric safety regulations when installing the unit.
- (2) According to the local safety regulations, use qualified power supply circuit and air switch.
- (3) Make sure the power supply matches with the requirement of air conditioner. Unstable power supply or incorrect wiring may result in electric shock, fire hazard or malfunction. Please install proper power supply cables before using the air conditioner.
- (4) Properly connect the live wire, neutral wire and grounding wire of power socket.
- (5) Be sure to cut off the power supply before proceeding any work related to electricity and safety.
- (6) Do not put through the power before finishing installation.
- (7) If the supply cord is damaged, it must be replaced by the manufacturer, its service agent or similarly qualified persons in order to avoid a hazard.
- (8) The temperature of refrigerant circuit will be high, please keep the interconnection cable away from the copper tube.
- (9) The appliance shall be installed in accordance with national wiring regulations.
- (10) Appliance shall be installed, operated and stored in a room with a floor area larger than Xm^2 (Please refer to table "a" in section of " Safety Operation of Inflammable Refrigerant" for Space X.)



Please notice that the unit is filled with flammable gas R32. Inappropriate treatment of the unit involves the risk of severe damages of people and material. Details to this refrigerant are found in chapter "refrigerant".

2. Grounding Requirement:

- (1) The air conditioner is first class electric appliance. It must be properly grounding with specialized grounding device by a professional. Please make sure it is always grounded effectively, otherwise it may cause electric shock.
- (2) The yellow-green wire in air conditioner is grounding wire, which can't be used for other purposes.
- (3) The grounding resistance should comply with national electric safety regulations.
- (4) The appliance must be positioned so that the plug is accessible.
- (5) An all-pole disconnection switch having a contact separation of at least 3mm in all poles should be connected in fixed wiring.
- (6) Including an air switch with suitable capacity, please note the following table. Air switch should be included magnet buckle and heating buckle function, it can protect the circuit-short and overload. (Caution: please do not use the fuse only for protect the circuit)

Model	Air switch capacity	Power cord
9K	10A	3G1.0
12K	10A	3G1.0
18K	16A	3G1.5

8.5 Installation of Indoor Unit

1. Choosing Installation location

Recommend the installation location to the client and then confirm it with the client.

2. Install Wall-mounting Frame

- (1) Hang the wall-mounting frame on the wall; adjust it in horizontal position with the level meter and then point out the screw fixing holes on the wall.
- (2) Drill the screw fixing holes on the wall with impact drill (the specification of drill head should be the same as the plastic expansion particle) and then fill the plastic expansion particles

in the holes.

(3) Fix the wall-mounting frame on the wall with tapping screws and then check if the frame is firmly installed by pulling the frame. If the plastic expansion particle is loose, please drill another fixing hole nearby.

3. Install Wall-mounting Frame

(1) Choose the position of piping hole according to the direction of outlet pipe. The position of piping hole should be a little lower than the wall-mounted frame.(As show in Fig.1)

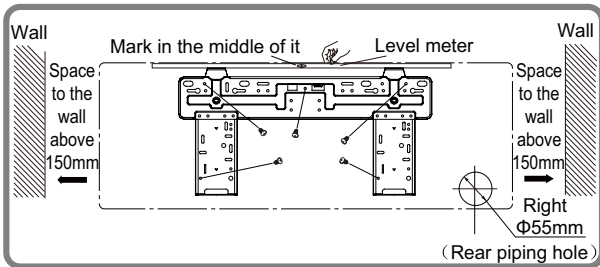

Fig.1

(2) Open a piping hole with the diameter of Φ55mm on the selected outlet pipe position. In order to drain smoothly, slant the piping hole on the wall slightly downward to the outdoor side with the gradient of 5-10°. (As show in Fig.2)

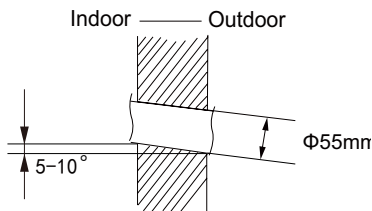

Fig.2

⚠ Note:

Pay attention to dust prevention and take relevant safety measures when opening the hole.

4. Outlet Pipe

(1) The pipe can be led out in the direction of right, rear right, left or rear left.(As show in Fig.3)

(2) When selecting leading out the pipe from left or right, please cut off the corresponding hole on the bottom case.(As show in Fig.4)

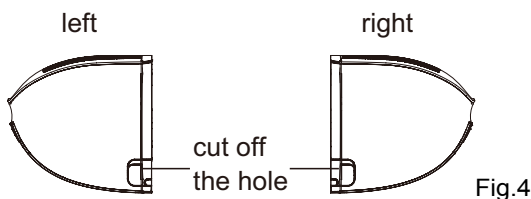
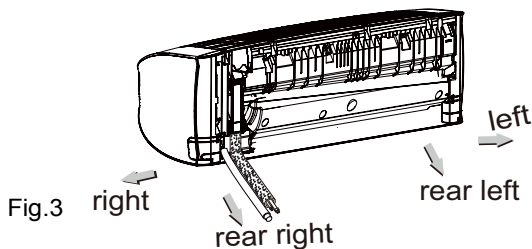

Fig.4

5. Connect the Pipe of Indoor Unit

(1) Aim the pipe joint at the corresponding bellmouth.(As show in Fig.5)

(2) Pretightening the union nut with hand.

(3) Adjust the torque force by referring to the following sheet. Place the open-end wrench on the pipe joint and place the torque wrench on the union nut. Tighten the union nut with torque wrench.(As show in Fig.6)

(4) Wrap the indoor pipe and joint of connection pipe with insulating pipe, and then wrap it with tape.(As show in Fig.7)

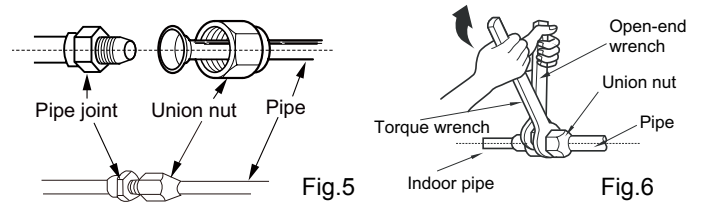

Fig.5

Fig.6

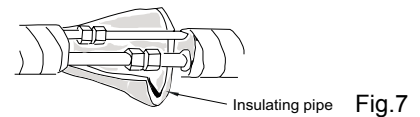

Fig.7

Refer to the following table for wrench moment of force:

Hex nut diameter(mm)	Tightening torque(N·m)
Φ6	15~20
Φ9.52	30~40
Φ12	45~55
Φ16	60~65
Φ19	70~75

6. Install Drain Hose

(1) Connect the drain hose to the outlet pipe of indoor unit.(As show in Fig.8)

(2) Bind the joint with tape.(As show in Fig.9)

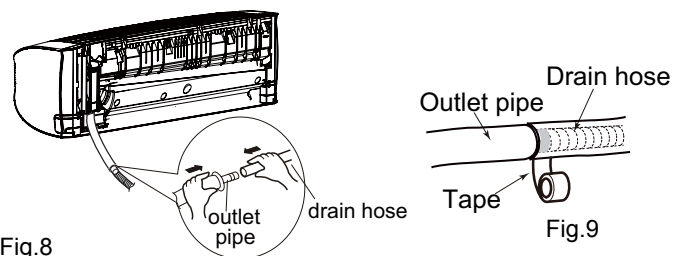

Fig.8

Fig.9

⚠ Note:

(1) Add insulating pipe in the indoor drain hose in order to prevent condensation.(As show in Fig.10)

(2) The drain pipe can only exit from the right or rear right side, otherwise it may cause water leakage.

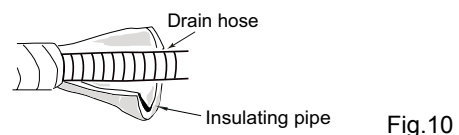
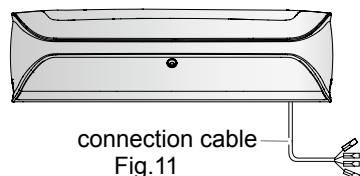

Fig.10

7. Connect Wire of Indoor Unit

The connection wire of indoor unit has been assembled before ex-factory, so you only need to check if it is loose before connecting wire.



connection cable
Fig.11

⚠ Note:

If the length of power connection wire is insufficient, please contact the supplier for a new one. Avoid extending the wire by yourself.

8. Bind up Pipe

- (1) Bind up the connection pipe, power cord and drain hose with the band.(As show in Fig.12)
- (2) Reserve a certain length of drain hose and power cord for installation when binding them. When binding to a certain degree, separate the indoor power and then separate the drain hose.(As show in Fig.13)
- (3) Bind them evenly.
- (4) The liquid pipe and gas pipe should be bound separately at the end.

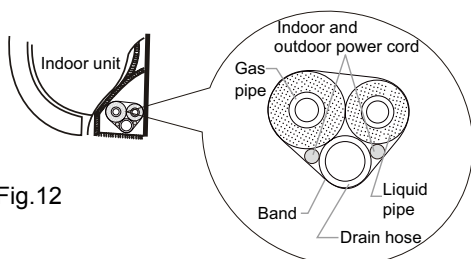

Fig.12

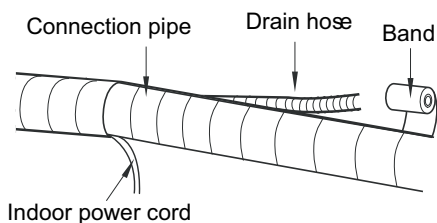

Fig.13

⚠ Note:

- (1) The power cord and control wire can't be crossed or winding.
- (2) The drain hose should be bound at the bottom.

9. Hang the Indoor Unit

- (1) Put the bound pipes in the wall pipe and then make them pass through the wall hole.
- (2) Hang the indoor unit on the wall-mounting frame.
- (3) Stuff the gap between pipes and wall hole with sealing gum.
- (4) Fix the wall pipe.(As show in Fig.14)
- (5) Check if the indoor unit is installed firmly and closed to the wall.(As show in Fig.15)

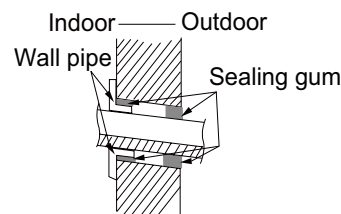

Fig.14

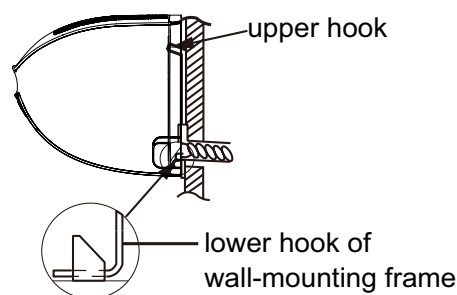

Fig.15

⚠ Note:

Do not bend the drain hose too excessively in order to prevent blocking.

8.6 Installation of Outdoor unit

1. Fix the Support of Outdoor Unit(Select it according to the actual installation situation)

- (1) Select installation location according to the house structure.
- (2) Fix the support of outdoor unit on the selected location with expansion screws.

⚠ Note:

- (1) Take sufficient protective measures when installing the outdoor unit.
- (2) Make sure the support can withstand at least four times the unit weight.
- (3) The outdoor unit should be installed at least 3cm above the floor in order to install drain joint.(As show in Fig.16)
- (4) For the unit with cooling capacity of 2300W~5000W, 6 expansion screws are needed; for the unit with cooling capacity of 6000W~8000W, 8 expansion screws are needed; for the unit with cooling capacity of 10000W~16000W, 10 expansion screws are needed.

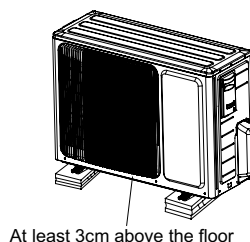

At least 3cm above the floor

Fig.16

2. Install Drain Joint(Only for Cooling and Heating Unit)

- (1) Connect the outdoor drain joint into the hole on the chassis.
- (2) Connect the drain hose into the drain vent.(As show in Fig.17)

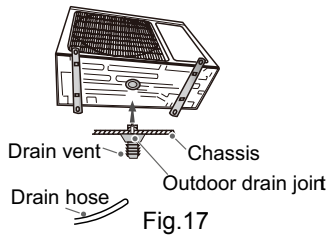

3. Fix Outdoor Unit

- (1) Place the outdoor unit on the support.
- (2) Fix the foot holes of outdoor unit with bolts.
(As show in Fig.18)

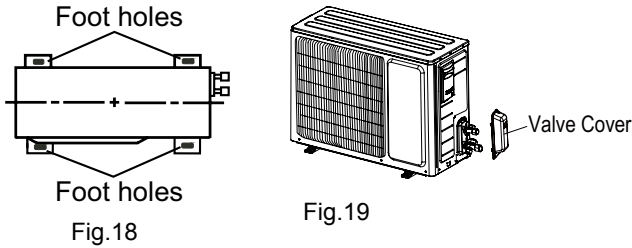

4. Connect Indoor and Outdoor Pipes

- (1) Remove the screw on the right handle of outdoor unit and then remove the valve cover.(As show in Fig.19)
- (2) Remove the screw cap of valve and aim the pipe joint at the bellmouth of pipe.(As show in Fig.20)

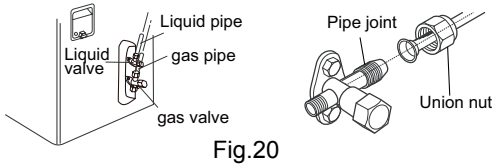

- (3) Pretightening the union nut with hand.
 - (4) Tighten the union nut with torque wrench .
- Refer to the following table for wrench moment of force:

Hex nut diameter	Tightening torque(N·m)
Φ6	15~20
Φ9.52	30~40
Φ12	45~55
Φ16	60~65
Φ19	70~75

5. Connect Outdoor Electric Wire

- (1) Remove the valve cover.
- (2) Remove the wire clip; connect the power connection wire and power cord to the wiring terminal according to the color; fix them with screws.(As show in Fig.21)

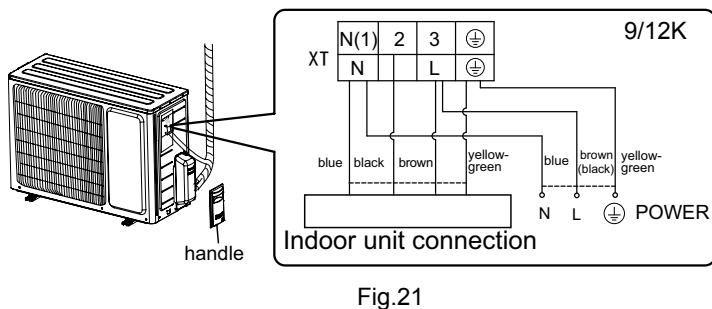
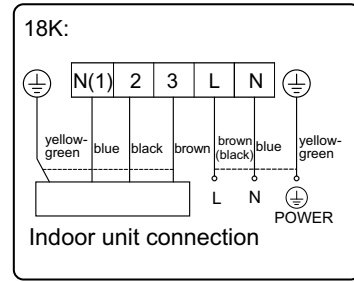

Fig.21



Note: the wiring board is for reference only, please refer to the actual one.

- (2) Fix the power connection wire and power cord with wire clip.

⚠ Note:

- (1) After tightening the screw, pull the power cord slightly to check if it is firm.
- (2) Never cut the power connection wire to prolong or shorten the distance.

6. Neaten the Pipes

- (1) The pipes should be placed along the wall, bent reasonably and hidden possibly. Min. semidiameter of bending the pipe is 10cm.
- (2) If the outdoor unit is higher than the wall hole, you must set a U-shaped curve in the pipe before pipe goes into the room, in order to prevent rain from getting into the room.(As show in Fig.22)

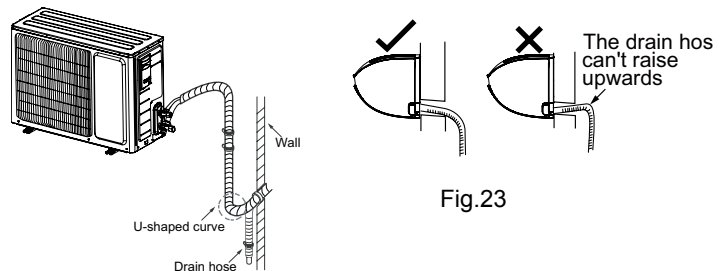

Fig.22

⚠ Note:

- (1) The through-wall height of drain hose shouldnt be higher than the outlet pipe hole of indoor unit.(As show in Fig.23)
- (2) Slant the drain hose slightly downwards. The drain hose can't be curved, raised and fluctuant, etc.(As show in Fig.24)
- (3) The water outlet can't be placed in water in order to drain smoothly.(As show in Fig.25)

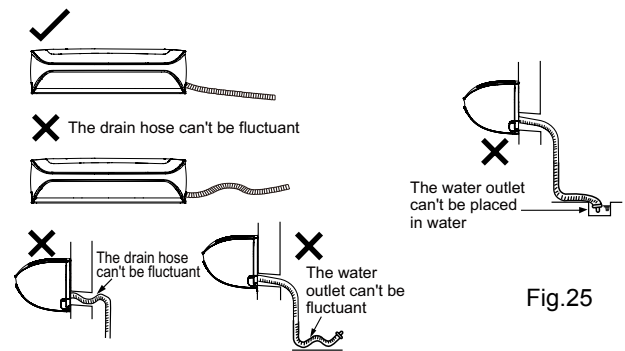

Fig.24

Fig.25

8.7 Vacuum Pumping and Leak

Detection

1. Use Vacuum Pump

(1) Remove the valve caps on the liquid valve and gas valve and the nut of refrigerant charging vent.

(2) Connect the charging hose of piezometer to the refrigerant charging vent of gas valve and then connect the other charging hose to the vacuum pump.

(3) Open the piezometer completely and operate for 10-15min to check if the pressure of piezometer remains in -0.1MPa.

(4) Close the vacuum pump and maintain this status for 1-2min to check if the pressure of piezometer remains in -0.1MPa. If the pressure decreases, there may be leakage.

(5) Remove the piezometer, open the valve core of liquid valve and gas valve completely with inner hexagon spanner.

(6) Tighten the screw caps of valves and refrigerant charging vent.(As show in Fig.26)

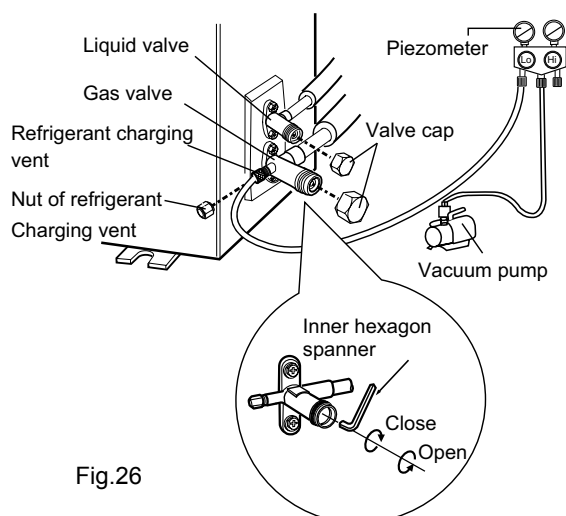

Fig.26

2. Leakage Detection

(1) With leakage detector:

Check if there is leakage with leakage detector.

(2) With soap water:

If leakage detector is not available, please use soap water for leakage detection. Apply soap water at the suspected position and keep the soap water for more than 3min. If there are air bubbles coming out of this position, there's a leakage.

8.8 Check after Installation and Test Operation

1. Check after Installation

Check according to the following requirement after finishing installation.

NO.	Items to be checked	Possible malfunction
1	Has the unit been installed firmly?	The unit may drop, shake or emit noise.
2	Have you done the refrigerant leakage test?	It may cause insufficient cooling (heating) capacity.
3	Is heat insulation of pipeline sufficient?	It may cause condensation and water dripping.
4	Is water drained well?	It may cause condensation and water dripping.
5	Is the voltage of power supply according to the voltage marked on the nameplate?	It may cause malfunction or damage the parts.
6	Is electric wiring and pipeline installed correctly?	It may cause malfunction or damage the parts.
7	Is the unit grounded securely?	It may cause electric leakage.
8	Does the power cord follow the specification?	It may cause malfunction or damage the parts.
9	Is there any obstruction in air inlet and air outlet?	It may cause insufficient cooling (heating) capacity.
10	The dust and sundries caused during installation are removed?	It may cause malfunction or damaging the parts.
11	The gas valve and liquid valve of connection pipe are open completely?	It may cause insufficient cooling (heating) capacity.
12	Is the inlet and outlet of piping hole been covered?	It may cause insufficient cooling (heating) capacity or waster eletricity.

2. Test Operation

(1) Preparation of test operation

- The client approves the air conditioner installation.
- Specify the important notes for air conditioner to the client.

(2) Method of test operation

- Put through the power, press ON/OFF button on the remote controller to start operation.
- Press MODE button to select AUTO, COOL, DRY, FAN and HEAT to check whether the operation is normal or not.
- If the ambient temperature is lower than 16℃, the air conditioner can't start cooling.

9. Maintenance

9.1 Error Code List

NO.	Malfunction Name	Display Method of Indoor Unit			A/C status	Possible Causes	
		Dual-8 Code Display	Indicator Display (during blinking, ON 0.5s and OFF 0.5s)				
			Operation Indicator	Cool Indicator			Heating Indicator
1	High pressure protection of system	E1				During cooling and drying operation, except indoor fan operates, all loads stop operation. During heating operation, the complete unit stops.	Possible reasons: 1. Refrigerant was superabundant; 2. Poor heat exchange (including filth blockage of heat exchanger and bad radiating environment); Ambient temperature is too high.
2	Antifreezing protection	E2				During cooling and drying operation, compressor and outdoor fan stop while indoor fan operates.	1. Poor air-return in indoor unit; 2. Fan speed is abnormal; 3. Evaporator is dirty.
3	Refrigerant leakage protection	F0				The Dual-8 Code Display will show F0 and the complete unit stops.	1.Refrigerant leakage; 2.Indoor evaporator temperature sensor works abnormally; 3.The unit has been plugged up somewhere.
4	High discharge temperature protection of compressor	E4				During cooling and drying operation, compressor and outdoor fan stop while indoor fan operates. During heating operation, all loads stop.	Please refer to the malfunction analysis (discharge protection, overload).
5	Overcurrent protection	E5				During cooling and drying operation, compressor and outdoor fan stop while indoor fan operates. During heating operation, all loads stop.	1. Supply voltage is unstable; 2. Supply voltage is too low and load is too high; 3. Evaporator is dirty.
6	Communication Malfunction	E6				During cooling operation, compressor stops while indoor fan motor operates. During heating operation, the complete unit stops.	Refer to the corresponding malfunction analysis.
7	High temperature resistant protection	E8				During cooling operation: compressor will stop while indoor fan will operate. During heating operation, the complete unit stops.	Refer to the malfunction analysis (overload, high temperature resistant).
8	EEPROM malfunction	EE				During cooling and drying operation, compressor will stop while indoor fan will operate; During heating operation, the complete unit will stop	Replace outdoor control panel AP1
9	Limit/ decrease frequency due to high temperature of module	EU				All loads operate normally, while operation frequency for compressor is decreased	Discharging after the complete unit is de-energized for 20mins, check whether the thermal grease on IPM Module of outdoor control panel AP1 is sufficient and whether the radiator is inserted tightly. If its no use, please replace control panel AP1.
10	Malfunction protection of jumper cap	C5				Wireless remote receiver and button are effective, but can not dispose the related command	1. No jumper cap insert on mainboard. 2. Incorrect insert of jumper cap. 3. Jumper cap damaged. 4. Abnormal detecting circuit of mainboard.

NO.	Malfunction Name	Display Method of Indoor Unit				A/C status	Possible Causes
		Dual-8 Code Display	Indicator Display (during blinking, ON 0.5s and OFF 0.5s)				
			Operation Indicator	Cool Indicator	Heating Indicator		
11	Gathering refrigerant	Fo				When the outdoor unit receive signal of Gathering refrigerant ,the system will be forced to run under cooling mode for gathering refrigerant	Nominal cooling mode
12	Indoor ambient temperature sensor is open/short circuited	F1				During cooling and drying operation, indoor unit operates while other loads will stop; during heating operation, the complete unit will stop operation.	1. Loosening or bad contact of indoor ambient temp. sensor and mainboard terminal. 2. Components in mainboard fell down leads short circuit. 3. Indoor ambient temp. sensor damaged.(check with sensor resistance value chart) 4. Mainboard damaged.
13	Indoor evaporator temperature sensor is open/short circuited	F2				AC stops operation once reaches the setting temperature. Cooling, drying: internal fan motor stops operation while other loads stop operation; heating: AC stop operation	1. Loosening or bad contact of Indoor evaporator temp. sensor and mainboard terminal. 2. Components on the mainboard fall down leads short circuit. 3. Indoor evaporator temp. sensor damaged.(check temp. sensor value chart for testing) 4. Mainboard damaged.
14	Outdoor ambient temperature sensor is open/short circuited	F3				During cooling and drying operating, compressor stops while indoor fan operates; During heating operation, the complete unit will stop operation	Outdoor temperature sensor hasnt been connected well or is damaged. Please check it by referring to the resistance table for temperature sensor)
15	Outdoor condenser temperature sensor is open/short circuited	F4				During cooling and drying operation, compressor stops while indoor fan will operate; During heating operation, the complete unit will stop operation.	Outdoor temperature sensor hasnt been connected well or is damaged. Please check it by referring to the resistance table for temperature sensor)
16	Outdoor discharge temperature sensor is open/short circuited	F5				During cooling and drying operation, compressor will sop after operating for about 3 mins, while indoor fan will operate; During heating operation, the complete unit will stop after operating for about 3 mins.	1.Outdoor temperature sensor hasnt been connected well or is damaged. Please check it by referring to the resistance table for temperature sensor) 2.The head of temperature sensor hasnt been inserted into the copper tube
17	Limit/ decrease frequency due to overload	F6				All loads operate normally, while operation frequency for compressor is decreased	Refer to the malfunction analysis (overload, high temperature resistant)
18	Decrease frequency due to overcurrent	F8				All loads operate normally, while operation frequency for compressor is decreased	The input supply voltage is too low; System pressure is too high and overload

NO.	Malfunction Name	Display Method of Indoor Unit				A/C status	Possible Causes
		Dual-8 Code Display	Indicator Display (during blinking, ON 0.5s and OFF 0.5s)				
			Operation Indicator	Cool Indicator	Heating Indicator		
19	Decrease frequency due to high air discharge	F9				All loads operate normally, while operation frequency for compressor is decreased	Overload or temperature is too high; Refrigerant is insufficient; Malfunction of electric expansion valve (EKV)
20	Limit/decrease frequency due to antifreezing	FH				All loads operate normally, while operation frequency for compressor is decreased	Poor air-return in indoor unit or fan speed is too low
21	Voltage for DC bus-bar is too high	PH				During cooling and drying operation, compressor will stop while indoor fan will operate; During heating operation, the complete unit will stop operation.	1. Measure the voltage of position L and N on wiring board (XT), if the voltage is higher than 265VAC, turn on the unit after the supply voltage is increased to the normal range. 2.If the AC input is normal, measure the voltage of electrolytic capacitor C on control panel (AP1), if its normal, theres malfunction for the circuit, please replace the control panel (AP1)
22	Voltage of DC bus-bar is too low	PL				During cooling and drying operation, compressor will stop while indoor fan will operate; During heating operation, the complete unit will stop	1. Measure the voltage of position L and N on wiring board (XT), if the voltage is higher than 150VAC, turn on the unit after the supply voltage is increased to the normal range. 2.If the AC input is normal, measure the voltage of electrolytic capacitor C on control panel (AP1), if its normal, theres malfunction for the circuit, please replace the control panel (AP1)
23	Compressor Min frequency in test state	P0					Showing during min. cooling or min. heating test
24	Compressor rated frequency in test state	P1					Showing during nominal cooling or nominal heating test
25	Compressor maximum frequency in test state	P2					Showing during max. cooling or max. heating test

NO.	Malfunction Name	Display Method of Indoor Unit				A/C status	Possible Causes
		Dual-8 Code Display	Indicator Display (during blinking, ON 0.5s and OFF 0.5s)				
			Operation Indicator	Cool Indicator	Heating Indicator		
26	Compressor intermediate frequency in test state	P3					Showing during middle cooling or middle heating test
27	Overcurrent protection of phase current for compressor	P5				During cooling and drying operation, compressor will stop while indoor fan will operate; During heating operation, the complete unit will stop operation.	Refer to the malfunction analysis (IPM protection, loss of synchronism protection and overcurrent protection of phase current for compressor).
28	Charging malfunction of capacitor	PU				During cooling and drying operation, compressor will stop while indoor fan will operate; During heating operation, the complete unit will stop	Refer to the part three—charging malfunction analysis of capacitor
29	Malfunction of module temperature sensor circuit	P7				During cooling and drying operation, compressor will stop while indoor fan will operate; During heating operation, the complete unit will stop	Replace outdoor control panel AP1
30	Module high temperature protection	P8				During cooling operation, compressor will stop while indoor fan will operate; During heating operation, the complete unit will stop	After the complete unit is de-energized for 20mins, check whether the thermal grease on IPM Module of outdoor control panel AP1 is sufficient and whether the radiator is inserted tightly. If its no use, please replace control panel AP1.
31	Decrease frequency due to high temperature resistant during heating operation	H0				All loads operate normally, while operation frequency for compressor is decreased	Refer to the malfunction analysis (overload, high temperature resistant)
32	Static dedusting protection	H2					
33	Overload protection for compressor	H3				During cooling and drying operation, compressor will stop while indoor fan will operate; During heating operation, the complete unit will stop operation.	1. Wiring terminal OVC-COMP is loosened. In normal state, the resistance for this terminal should be less than 1ohm. 2.Refer to the malfunction analysis (discharge protection, overload)

NO.	Malfunction Name	Display Method of Indoor Unit				A/C status	Possible Causes
		Dual-8 Code Display	Indicator Display (during blinking, ON 0.5s and OFF 0.5s)				
			Operation Indicator	Cool Indicator	Heating Indicator		
34	System is abnormal	H4				During cooling and drying operation, compressor will stop while indoor fan will operate; During heating operation, the complete unit will stop operation.	Refer to the malfunction analysis (overload, high temperature resistant)
35	IPM protection	H5				During cooling and drying operation, compressor will stop while indoor fan will operate; During heating operation, the complete unit will stop operation.	Refer to the malfunction analysis (IPM protection, loss of synchronism protection and overcurrent protection of phase current for compressor.
36	Internal motor (fan motor) do not operate	H6				Internal fan motor, external fan motor, compressor and electric heater stop operation,guide louver stops at present location.	<ol style="list-style-type: none"> 1. Bad contact of DC motor feedback terminal. 2. Bad contact of DC motor control end. 3. Fan motor is stalling. 4. Motor malfunction. 5. Malfunction of mainboard rev detecting circuit.
37	Desynchronizing of compressor	H7				During cooling and drying operation, compressor will stop while indoor fan will operate; During heating operation, the complete unit will stop operation.	Refer to the malfunction analysis (IPM protection, loss of synchronism protection and overcurrent protection of phase current for compressor.
38	PFC protection	HC				During cooling and drying operation, compressor will stop while indoor fan will operate; During heating operation, the complete unit will stop operation.	Replace outdoor control panel AP1 or Reactor
39	Outdoor DC fan motor malfunction	L3				Outdoor DC fan motor malfunction lead to compressor stop operation,	DC fan motor malfunction or system blocked or the connector loosed
40	power protection	L9				compressor stop operation and Outdoor fan motor will stop 30s latter , 3 minutes latter fan motor and compressor will restart	To protect the electrical components when detect high power
41	Indoor unit and outdoor unit doesn't match	LP				compressor and Outdoor fan motor can't work	Indoor unit and outdoor unit doesn't match
42	Failure start-up	LC				During cooling and drying operation, compressor will stop while indoor fan will operate; During heating operation, the complete unit will stop operation.	Refer to the malfunction analysis

NO.	Malfunction Name	Display Method of Indoor Unit			A/C status	Possible Causes	
		Dual-8 Code Display	Indicator Display (during blinking, ON 0.5s and OFF 0.5s)				
			Operation Indicator	Cool Indicator			Heating Indicator
43	Malfunction of phase current detection circuit for compressor	U1				During cooling and drying operation, compressor will stop while indoor fan will operate; During heating operation, the complete unit will stop	Replace outdoor control panel AP1
44	Malfunction of voltage dropping for DC bus-bar	U3				During cooling and drying operation, compressor will stop while indoor fan will operate; During heating operation, the complete unit will stop	Supply voltage is unstable
45	Malfunction of complete units current detection	U5				During cooling and drying operation, the compressor will stop while indoor fan will operate; During heating operating, the complete unit will stop operation.	Theres circuit malfunction on outdoor units control panel AP1, please replace the outdoor units control panel AP1.
46	The four-way valve is abnormal	U7				If this malfunction occurs during heating operation, the complete unit will stop operation.	1. Supply voltage is lower than AC175V; 2. Wiring terminal 4V is loosened or broken; 3. 4V is damaged, please replace 4V.
47	Zero-crossing malfunction of outdoor unit	U9				During cooling operation, compressor will stop while indoor fan will operate; during heating, the complete unit will stop operation.	Replace outdoor control panel AP1
48	Defrosting		OFF 3S and blink once (during blinking, ON 10s and OFF 0.5s)			Defrosting will occur in heating mode. Compressor will operate while indoor fan will stop operation.	Its the normal state
49	Malfunction of zero-cross detection circuit	U8				The complete unit stops	1. Power supply is abnormal; 2. Detection circuit of indoor control mainboard is abnormal.
50	Malfunction of detecting plate(WIFI)	JF				Loads operate normally, while the unit can't be normally controlled by APP.	1. Main board of indoor unit is damaged; 2. Detection board is damaged; 3. The connection between indoor unit and detection board is not good;

NO.	Malfunction Name	Display Method of indoor unit				A/C status	Possible Causes
		Dual-8 code Display	Indicator Display(during blinking, ON 0.5s and OFF 0.5s)				
			Operation Indicator	Cool Indicator	Heating Indicator		
51	Communication malfunction between display board and IDU mainboard	e6				Cooling: compressor stops, outdoor fan stops, indoor fan operates Heating: compressor stops, outdoor fan stops, indoor fan stops	1. Poor connection between display board and mainboard 2. Connection wire between display board and mainboard is broken 3. Failure of display board: communication failure with the mainboard 4. Failure of mainboard: communication failure with the mainboard with the display board
52	Communication malfunction between display board and I Sense board (use remote control to display the malfunction or cancel display ("press Light button for 6 times within 4s"))	e2				The unit operates normally Some I Sense function is failed	1. Model without I Sense detection device: if this malfunction is reported, please check if the selected jumper cap is correct? 2. Model with I Sense detection device: connection failure between display board and I Sense conversion board? 3. Model with I Sense detection device: connection wire between display board and I Sense conversion board is broken? 4. Model with I Sense detection device: failure of display board: communication failure with I Sense board 5. Model with I Sense detection device: failure of I Sense conversion board: communication failure with display board?
53	Communication malfunction between I Sense board conversion board and GridEye sensor	rE				The unit operates normally Failure of some I Sense functions	Model without I Sense detection device: if this malfunction is reported, please check if the selected jumper cap is correct? Model with I Sense detection device: 1. I Sense conversion board and I Sense sensor are connected improperly 2. Connection wire between I Sense conversion board and I Sense sensor is broken 3. Failure of I Sense conversion board: communication failure with I Sense sensor? 4. Failure of I Sense sensor?

9.2 Troubleshooting for Main Malfunction

1. Malfunction of Temperature Sensor F1, F2

Main detection points:

- Is the wiring terminal between the temperature sensor and the controller loosened or poorly contacted?
- Is there short circuit due to trip-over of the parts?
- Is the temperature sensor broken?
- Is mainboard broken?

Malfunction diagnosis process:

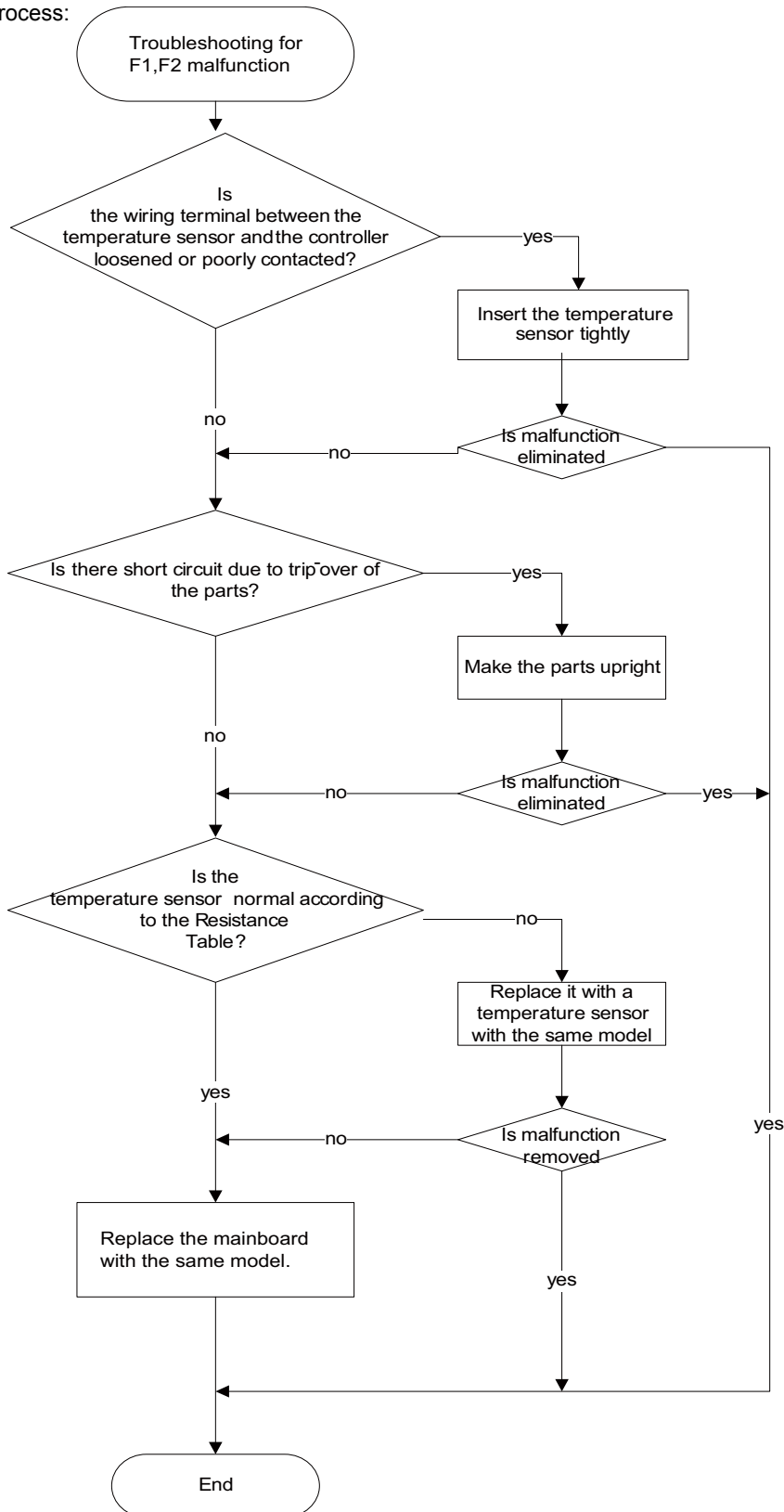

3. Malfunction of Protection of Jumper Cap C5

Main detection points:

- Malfunction Is there jumper cap on the mainboard?
- Is the jumper cap inserted correctly and tightly?
- The jumper is broken?
- Detection circuit of the mainboard is defined abnormal?

Malfunction diagnosis process:

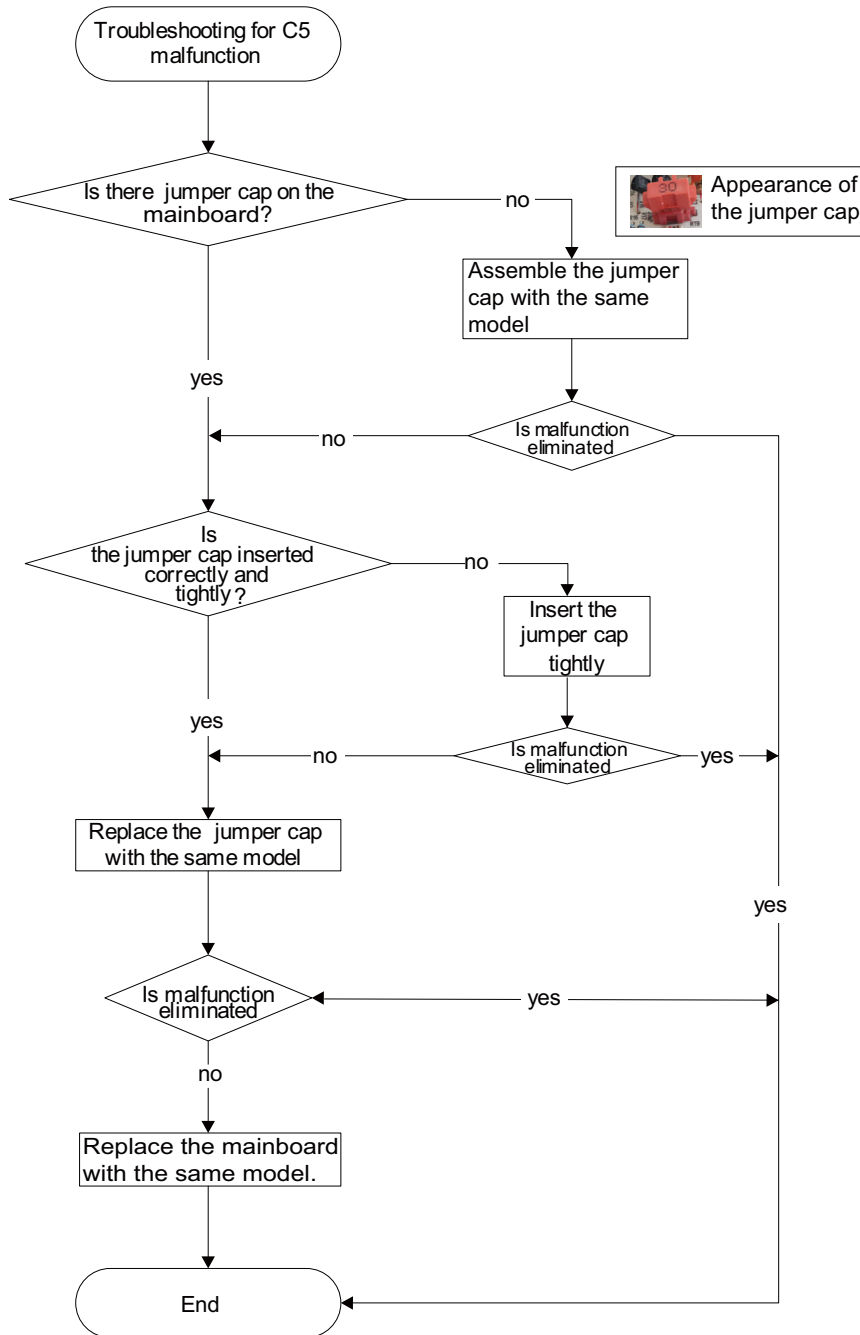

5. Communication Malfunction E6

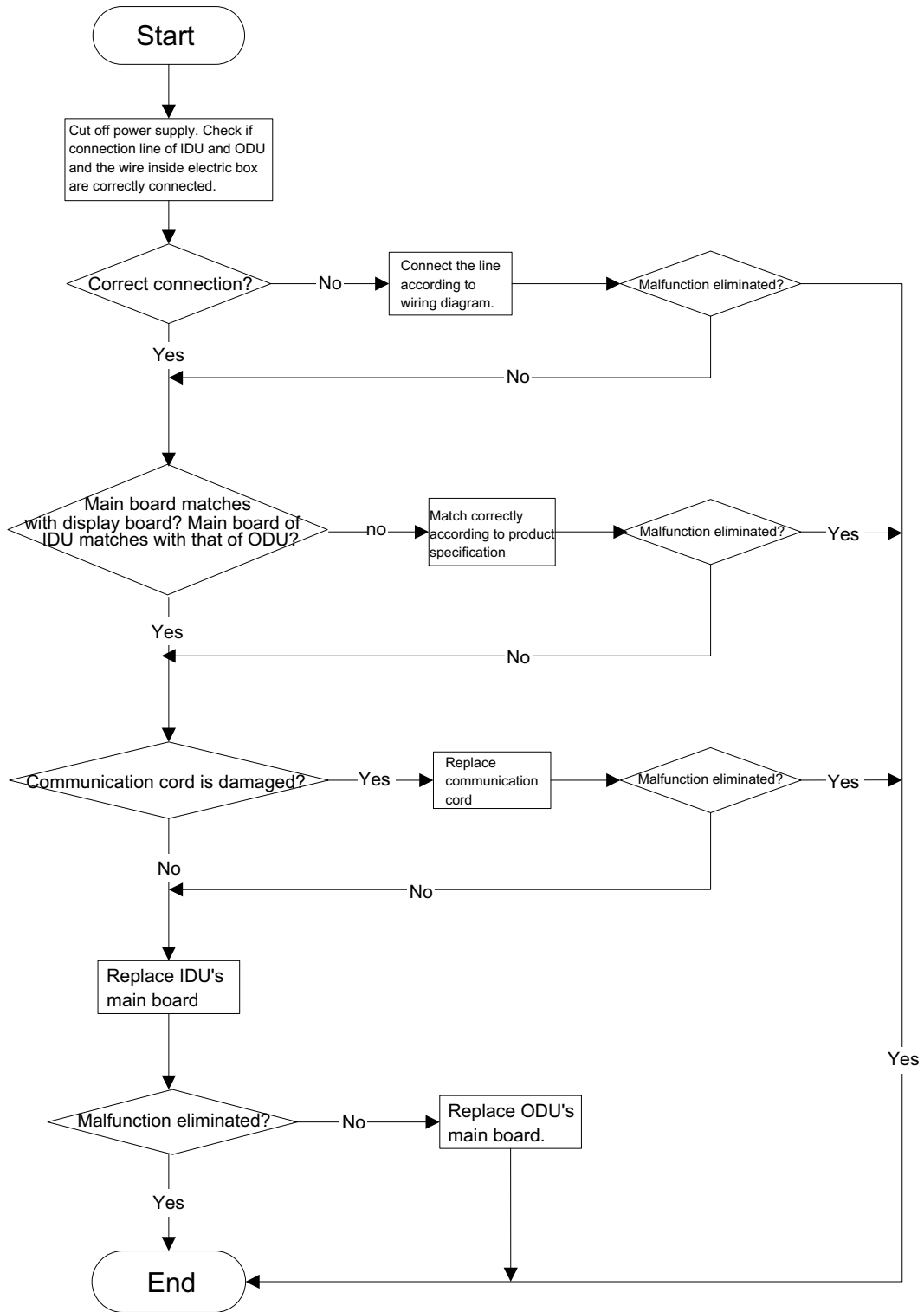

7. Malfunction of detecting plate(WIFI) JF

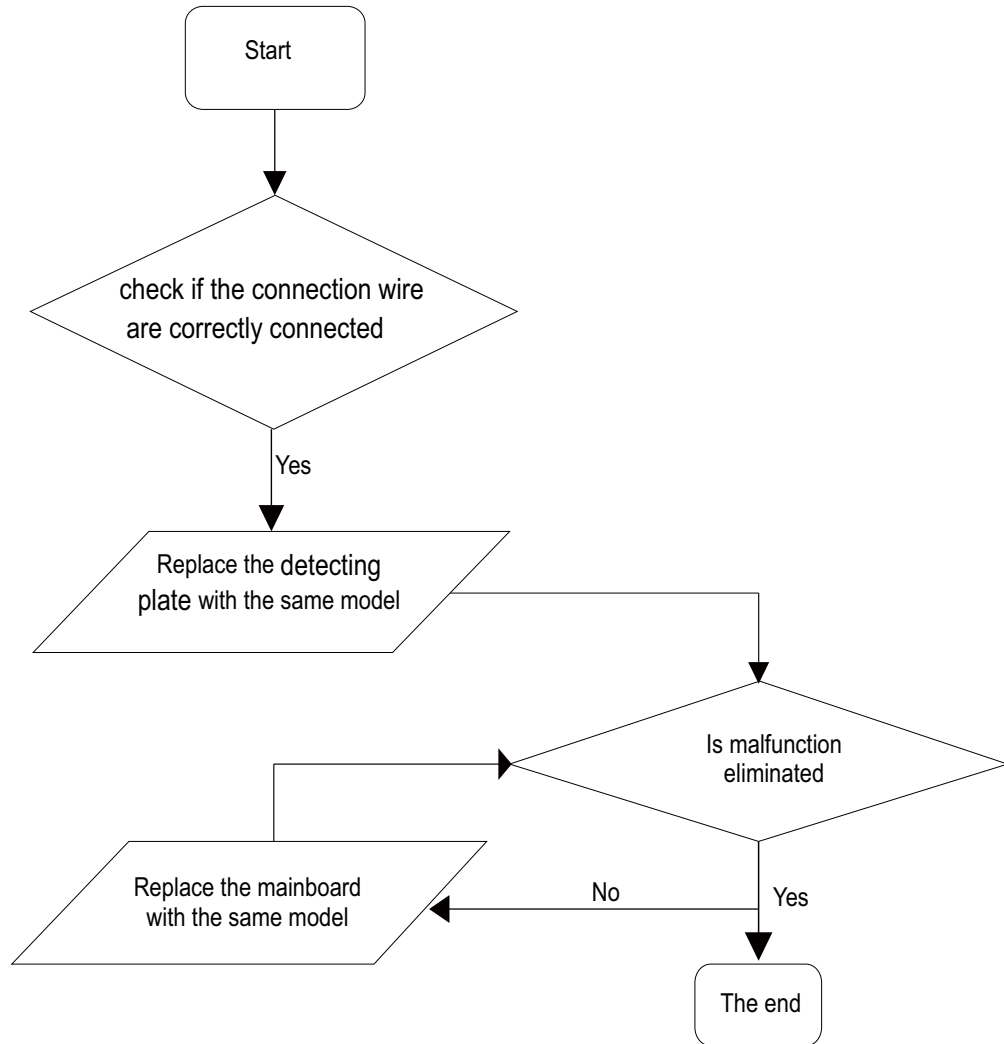

(2) **IPM protection, phase current overcurrent (the control board as below indicates the control board of outdoor unit) H5/P5**

Mainly detect:

- (1) Compressor COMP terminal (2) voltage of power supply (3) compressor
- (4) Refrigerant-charging volume (5) air outlet and air inlet of outdoor/indoor unit

Troubleshooting:

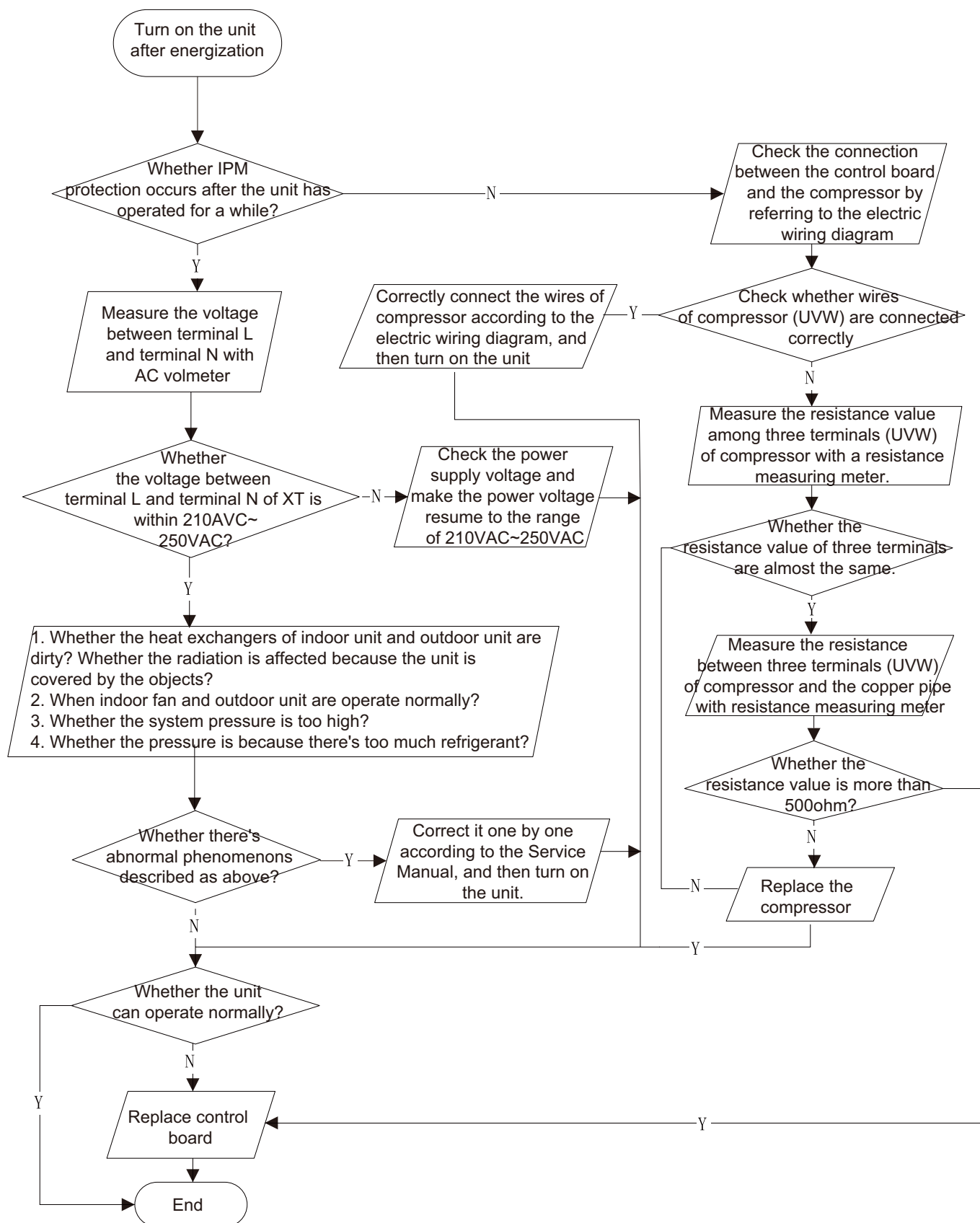

(4) Start-up failure (following AP1 for outdoor unit control board)

Mainly detect:

- Whether the compressor wiring is connected correct?
- Is compressor broken?
- Is time for compressor stopping enough?

Fault diagnosis process:

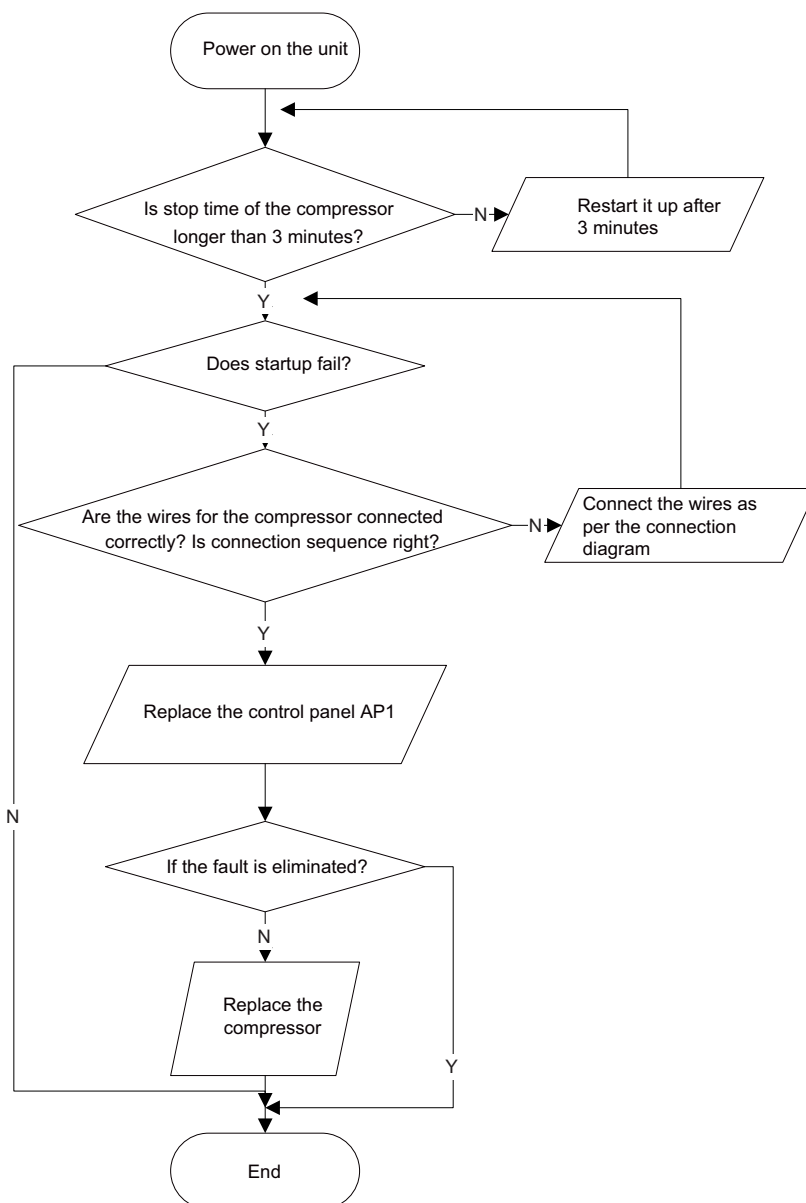

(6) Overload and air exhaust malfunction diagnosis (following AP1 for outdoor unit control board)

Mainly detect:

- Is the PMV connected well or not? Is PMV damaged?
- Is refrigerant leaked?

Fault diagnosis process:

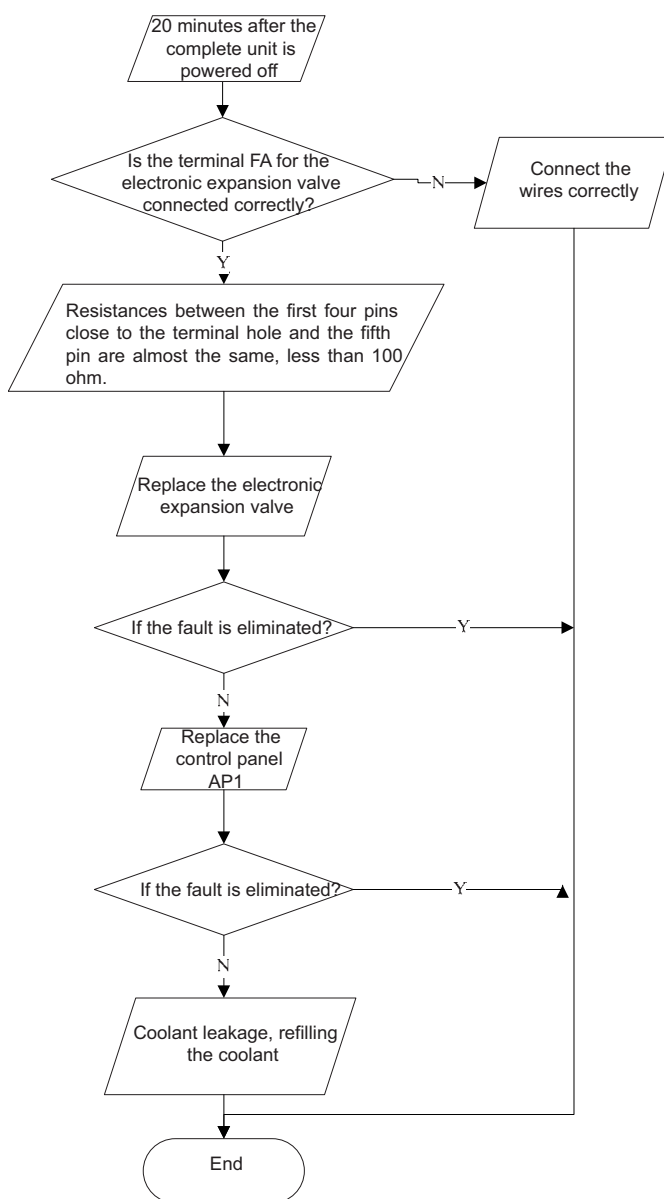

9.3 Troubleshooting for Normal Malfunction

1. Air Conditioner can't be Started Up

Possible Causes	Discriminating Method (Air conditioner Status)	Troubleshooting
No power supply, or poor connection for power plug	After energization, operation indicator isn't bright and the buzzer can't give out sound	Confirm whether it's due to power failure. If yes, wait for power recovery. If not, check power supply circuit and make sure the power plug is connected well.
Wrong wire connection between indoor unit and outdoor unit, or poor connection for wiring terminals	Under normal power supply circumstances, operation indicator isn't bright after energization	Check the circuit according to circuit diagram and connect wires correctly. Make sure all wiring terminals are connected firmly
Electric leakage for air conditioner	After energization, room circuit breaker trips off at once	Make sure the air conditioner is grounded reliably Make sure wires of air conditioner is connected correctly Check the wiring inside air conditioner. Check whether the insulation layer of power cord is damaged; if yes, place the power cord.
Model selection for air switch is improper	After energization, air switch trips off	Select proper air switch
Malfunction of remote controller	After energization, operation indicator is bright, while no display on remote controller or buttons have no action.	Replace batteries for remote controller Repair or replace remote controller

2. Poor Cooling (Heating) for Air Conditioner

Possible Causes	Discriminating Method (Air conditioner Status)	Troubleshooting
Set temperature is improper	Observe the set temperature on remote controller	Adjust the set temperature
Rotation speed of the IDU fan motor is set too low	Small wind blow	Set the fan speed at high or medium
Filter of indoor unit is blocked	Check the filter to see its blocked	Clean the filter
Installation position for indoor unit and outdoor unit is improper	Check whether the installation position is proper according to installation requirement for air conditioner	Adjust the installation position, and install the rainproof and sunproof for outdoor unit
Refrigerant is leaking	Discharged air temperature during cooling is higher than normal discharged wind temperature; Discharged air temperature during heating is lower than normal discharged wind temperature; unit's pressure is much lower than regulated range	Find out the leakage causes and deal with it. Add refrigerant.
Malfunction of 4-way valve	Blow cold wind during heating	Replace the 4-way valve
Malfunction of capillary	Discharged air temperature during cooling is higher than normal discharged wind temperature; Discharged air temperature during heating is lower than normal discharged wind temperature; Unit pressure is much lower than regulated range. If refrigerant isn't leaking, part of capillary is blocked	Replace the capillary
Flow volume of valve is insufficient	The pressure of valves is much lower than that stated in the specification	Open the valve completely
Malfunction of horizontal louver	Horizontal louver can't swing	Refer to point 3 of maintenance method for details
Malfunction of the IDU fan motor	The IDU fan motor can't operate	Refer to troubleshooting for H6 for maintenance method in details
Malfunction of the ODU fan motor	The ODU fan motor can't operate	Refer to point 4 of maintenance method for details
Malfunction of compressor	Compressor can't operate	Refer to point 5 of maintenance method for details

3. Horizontal Louver can't Swing

Possible Causes	Discriminating Method (Air conditioner Status)	Troubleshooting
Wrong wire connection, or poor connection	Check the wiring status according to circuit diagram	Connect wires according to wiring diagram to make sure all wiring terminals are connected firmly
Stepping motor is damaged	Stepping motor can't operate	Repair or replace stepping motor
Main board is damaged	Others are all normal, while horizontal louver can't operate	Replace the main board with the same model

4. ODU Fan Motor can't Operate

Possible causes	Discriminating method (air conditioner status)	Troubleshooting
Wrong wire connection, or poor connection	Check the wiring status according to circuit diagram	Connect wires according to wiring diagram to make sure all wiring terminals are connected firmly
Capacity of the ODU fan motor is damaged	Measure the capacity of fan capacitor with an universal meter and find that the capacity is out of the deviation range indicated on the nameplate of fan capacitor.	Replace the capacity of fan
Power voltage is a little low or high	Use universal meter to measure the power supply voltage. The voltage is a little high or low	Suggest to equip with voltage regulator
Motor of outdoor unit is damaged	When unit is on, cooling/heating performance is bad and ODU compressor generates a lot of noise and heat.	Change compressor oil and refrigerant. If no better, replace the compressor with a new one

5. Compressor can't Operate

Possible causes	Discriminating method (air conditioner status)	Troubleshooting
Wrong wire connection, or poor connection	Check the wiring status according to circuit diagram	Connect wires according to wiring diagram to make sure all wiring terminals are connected firmly
Capacity of compressor is damaged	Measure the capacity of fan capacitor with an universal meter and find that the capacity is out of the deviation range indicated on the nameplate of fan capacitor.	Replace the compressor capacitor
Power voltage is a little low or high	Use universal meter to measure the power supply voltage. The voltage is a little high or low	Suggest to equip with voltage regulator
Coil of compressor is burnt out	Use universal meter to measure the resistance between compressor terminals and it's 0	Repair or replace compressor
Cylinder of compressor is blocked	Compressor can't operate	Repair or replace compressor

6. Air Conditioner is Leaking

Possible causes	Discriminating method (air conditioner status)	Troubleshooting
Drain pipe is blocked	Water leaking from indoor unit	Eliminate the foreign objects inside the drain pipe
Drain pipe is broken	Water leaking from drain pipe	Replace drain pipe
Wrapping is not tight	Water leaking from the pipe connection place of indoor unit	Wrap it again and bundle it tightly

7. Abnormal Sound and Vibration

Possible causes	Discriminating method (air conditioner status)	Troubleshooting
When turn on or turn off the unit, the panel and other parts will expand and there's abnormal sound	Theres the sound of "PAPA"	Normal phenomenon. Abnormal sound will disappear after a few minutes.
When turn on or turn off the unit, there's abnormal sound due to flow of refrigerant inside air conditioner	Water-running sound can be heard	Normal phenomenon. Abnormal sound will disappear after a few minutes.
Foreign objects inside the indoor unit or therere parts touching together inside the indoor unit	Theres abnormal sound fro indoor unit	Remove foreign objects. Adjust all parts position of indoor unit, tighten screws and stick damping plaster between connected parts
Foreign objects inside the outdoor unit or therere parts touching together inside the outdoor unit	Theres abnormal sound fro outdoor unit	Remove foreign objects. Adjust all parts position of outdoor unit, tighten screws and stick damping plaster between connected parts
Short circuit inside the magnetic coil	During heating, the way valve has abnormal electromagnetic sound	Replace magnetic coil
Abnormal shake of compressor	Outdoor unit gives out abnormal sound	Adjust the support foot mat of compressor, tighten the bolts
Abnormal sound inside the compressor	Abnormal sound inside the compressor	If add too much refrigerant during maintenance, please reduce refrigerant properly. Replace compressor for other circumstances.



10. Exploded View and Parts List

10.1 Indoor Unit

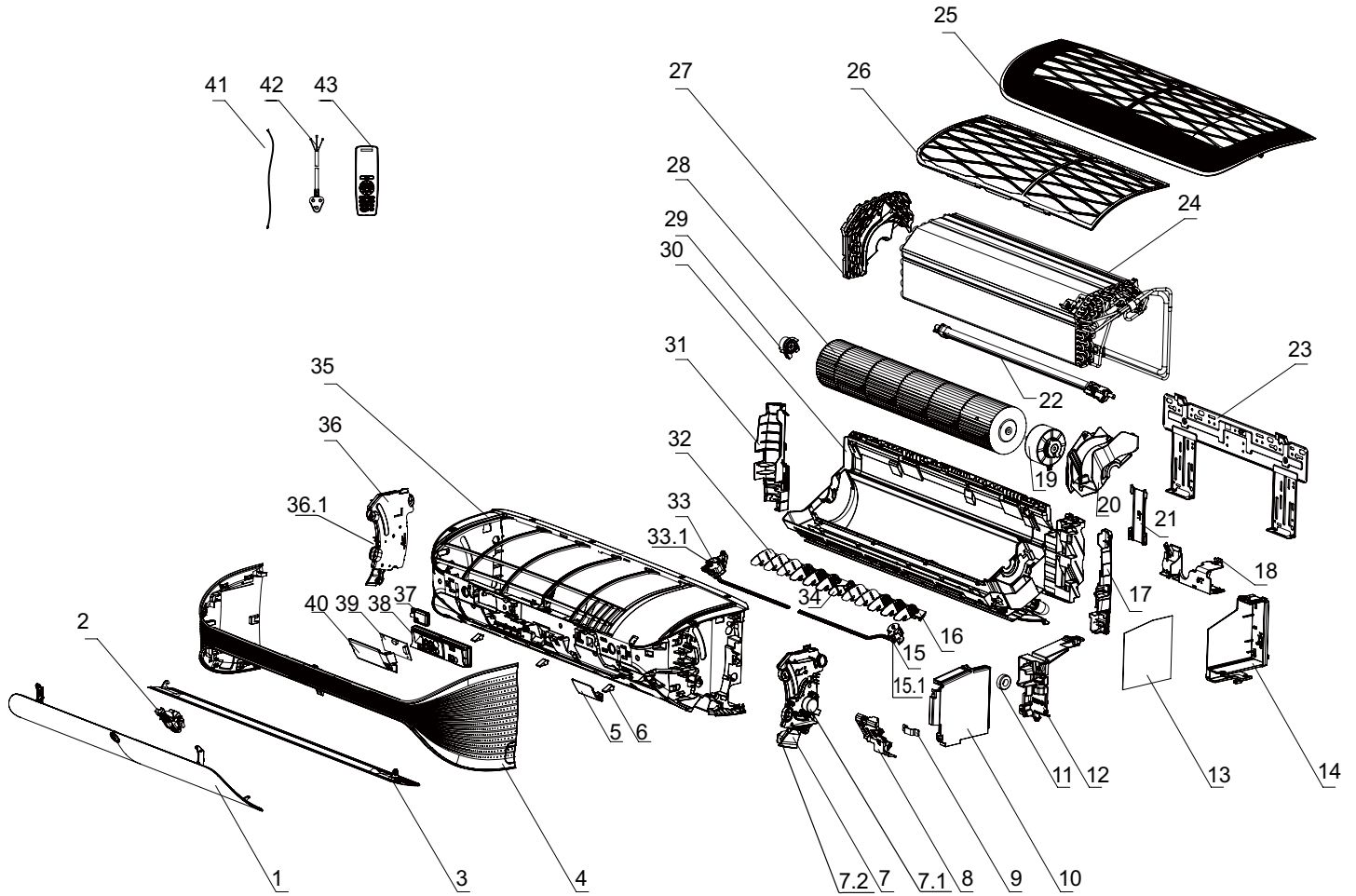

The component picture is only for reference; please refer to the actual product.

NO.	Description	Part Code		Qty
		GWH09AKC-K6DNA1A/I		
		Product Code		
		CB340N00100	CB340N00101	
1	Front Panel	200003060007T01	20000306000701T03	1
2	Sensor Sub-assy(HUMAN BODY INDUCTION METER)	000481000001	000481000003	1
3	Guide Louver	000136060015	000136060026	1
4	Decorative Board Sub-assy	000085060013	000085060009	1
5	Seal Cap(terminal)	200191060005	20019106000501P	1
6	Screw Cover	200005060002	0000506000201P	1
7	Right Driving Box Sub-assy	000045060002	000045060003	1
7.1	Stepping Motor	150102000006	150102000006	1
7.2	Connecting Rod Sub-assy	000110060002	000110060005	1
8	Holder (terminal)	200115060001	200115060001	1
9	Wire Clamp	200015060013	200015060013	1
10	Electric Box 3	200013060008	200013060008	1
11	Magnetic Ring	430005000003	430005000003	1
12	Electric Box 2	200013060007	200013060007	1
13	Main Board	300002061028	300002061028	1
14	Electric Box 1	200013060006	200013060006	1
15	Sweep Motor Assembly (right)	000211060002	000211060002	1
15.1	Stepping Motor	1501215201	1501215201	1
16	Air Louver(right)	200007060010	200007060010	1
17	Left Side Plate	200085060002	20008506000201P	1
18	Mouseproof Board	200071060001	200071060001	1
19	Fan Motor	15012466	15012466	1
20	Motor Press Plate	200020060001	200020060001	1
21	Connecting pipe clamp	24242024	24242024	1
22	Electric Heater	/	/	/
23	Wall Mounting Frame Sub-assy	01252021	01252021	1
24	Evaporator Assy	011001060221	011001060221	1
25	Into The Grid	200226060008	20022606000801P	1
26	Filter Sub-Assy	111001060011	11100106001101	1
27	Evaporator Support	200025060002	200025060002	1
28	Cross Flow Fan	103001060001	103001060001	1
29	Axile Bush Sub-assy	10542047	10542047	1
30	Rear Case Sub-Assy	00037706000501	00037706000501	1
31	Right Side Plate	200086060001	20008606000101P	1
32	Air Louver (left)	200007060001	200007060001	1
33	Sweep Motor Assembly (left)	000211060007	000211060007	1
33.1	Stepping Motor	1501215202	1501215202	1
34	Air Louver (Middle)	200007060011	200007060011	1
35	Front Case	200002060001	20000206000101P	1
36	Left Driving Box Sub-assy	10542039	10542039	1
36.1	Stepping Motor	150102000006	150102000006	1
37	Detecting Plate	30110144	30110144	1
38	Display Board	300001060535	300001060535	1
39	Pinboard	300023000007	300023000007	1
40	Seal Cap(HUMAN BODY INDUCTION board)	000503000001	000503000002	1
41	Connecting Cable	410103060036	410103060036	1
42	Connecting Cable	/	/	/
43	Remote Controller	305001060054	305001060054	1

Above data is subject to change without notice.

NO.	Description	Part Code		Qty
		GWH12AKC-K6DNA1A/I		
		Product Code		
		CB340N00200	CB340N00201	
1	Front Panel	200003060007T01	20000306000701T03	1
2	Sensor Sub-assy(HUMAN BODY INDUCTION METER)	000481000001	000481000003	1
3	Guide Louver	000136060015	000136060026	1
4	Decorative Board Sub-assy	000085060013	000085060009	1
5	Seal Cap(terminal)	200191060005	20019106000501P	1
6	Screw Cover	200005060002	0000506000201P	1
7	Right Driving Box Sub-assy	000045060002	000045060003	1
7.1	Stepping Motor	150102000006	150102000006	1
7.2	Connecting Rod Sub-assy	000110060002	000110060005	1
8	Holder (terminal)	200115060001	200115060001	1
9	Wire Clamp	200015060013	200015060013	1
10	Electric Box 3	200013060008	200013060008	1
11	Magnetic Ring	430005000003	430005000003	1
12	Electric Box 2	200013060007	200013060007	1
13	Main Board	300002061028	300002061028	1
14	Electric Box 1	200013060006	200013060006	1
15	Sweep Motor Assembly (right)	000211060002	000211060002	1
15.1	Stepping Motor	1501215201	1501215201	1
16	Air Louver(right)	200007060010	200007060010	1
17	Left Side Plate	200085060002	20008506000201P	1
18	Mouseproof Board	200071060001	200071060001	1
19	Fan Motor	15012466	15012466	1
20	Motor Press Plate	200020060001	200020060001	1
21	Connecting pipe clamp	24242024	24242024	1
22	Electric Heater	/	/	/
23	Wall Mounting Frame Sub-assy	01252021	01252021	1
24	Evaporator Assy	011001060221	011001060221	1
25	Into The Grid	200226060008	20022606000801P	1
26	Filter Sub-Assy	111001060011	11100106001101	1
27	Evaporator Support	200025060002	200025060002	1
28	Cross Flow Fan	103001060001	103001060001	1
29	Axile Bush Sub-assy	10542047	10542047	1
30	Rear Case Sub-Assy	00037706000501	00037706000501	1
31	Right Side Plate	200086060001	20008606000101P	1
32	Air Louver (left)	200007060001	200007060001	1
33	Sweep Motor Assembly (left)	000211060007	000211060007	1
33.1	Stepping Motor	1501215202	1501215202	1
34	Air Louver (Middle)	200007060011	200007060011	1
35	Front Case	200002060001	20000206000101P	1
36	Left Driving Box Sub-assy	10542039	10542039	1
36.1	Stepping Motor	150102000006	150102000006	1
37	Detecting Plate	30110144	30110144	1
38	Display Board	300001060535	300001060535	1
39	Pinboard	300023000007	300023000007	1
40	Seal Cap(HUMAN BODY INDUCTION board)	000503000001	000503000002	1
41	Connecting Cable	410103060036	410103060036	1
42	Connecting Cable	/	/	/
43	Remote Controller	305001060054	305001060054	1

Above data is subject to change without notice.

NO.	Description	Part Code	Qty
		GWH18AKC-K6DNA1A/I	
		Product Code	
		CB340N00300	
1	Front Panel	200003060007T01	1
2	Sensor Sub-assy(HUMAN BODY INDUCTION METER)	000481000001	1
3	Guide Louver	000136060015	1
4	Decorative Board Sub-assy	000085060013	1
5	Seal Cap(terminal)	200191060005	1
6	Screw Cover	200005060002	1
7	Right Driving Box Sub-assy	000045060002	1
7.1	Stepping Motor	150102000006	1
7.2	Connecting Rod Sub-assy	000110060002	1
8	Holder (terminal)	200115060001	1
9	Wire Clamp	200015060013	1
10	Electric Box 3	200013060008	1
11	Magnetic Ring	430005000003	1
12	Electric Box 2	200013060007	1
13	Main Board	300002061028	1
14	Electric Box 1	200013060006	1
15	Sweep Motor Assembly (right)	000211060002	1
15.1	Stepping Motor	1501215201	1
16	Air Louver(right)	200007060010	1
17	Left Side Plate	200085060002	1
18	Mouseproof Board	200071060001	1
19	Fan Motor	15012466	1
20	Motor Press Plate	200020060001	1
21	Connecting pipe clamp	24242024	1
22	Electric Heater	/	/
23	Wall Mounting Frame Sub-assy	01252021	1
24	Evaporator Assy	011001060049	1
25	Into The Grid	200226060008	1
26	Filter Sub-Assy	111001060011	1
27	Evaporator Support	200025060002	1
28	Cross Flow Fan	103001060001	1
29	Axile Bush Sub-assy	10542047	1
30	Rear Case Sub-Assy	00037706000501	1
31	Right Side Plate	200086060001	1
32	Air Louver (left)	200007060001	1
33	Sweep Motor Assembly (left)	000211060007	1
33.1	Stepping Motor	1501215202	1
34	Air Louver (Middle)	200007060011	1
35	Front Case	200002060001	1
36	Left Driving Box Sub-assy	10542039	1
36.1	Stepping Motor	150102000006	1
37	Detecting Plate	30110144	1
38	Display Board	300001060535	1
39	Pinboard	300023000007	1
40	Seal Cap(HUMAN BODY INDUCTION board)	000503000001	1
41	Connecting Cable	410103060036	1
42	Connecting Cable	/	/
43	Remote Controller	305001060054	1

Above data is subject to change without notice.

10.2 Outdoor Unit

9/12K

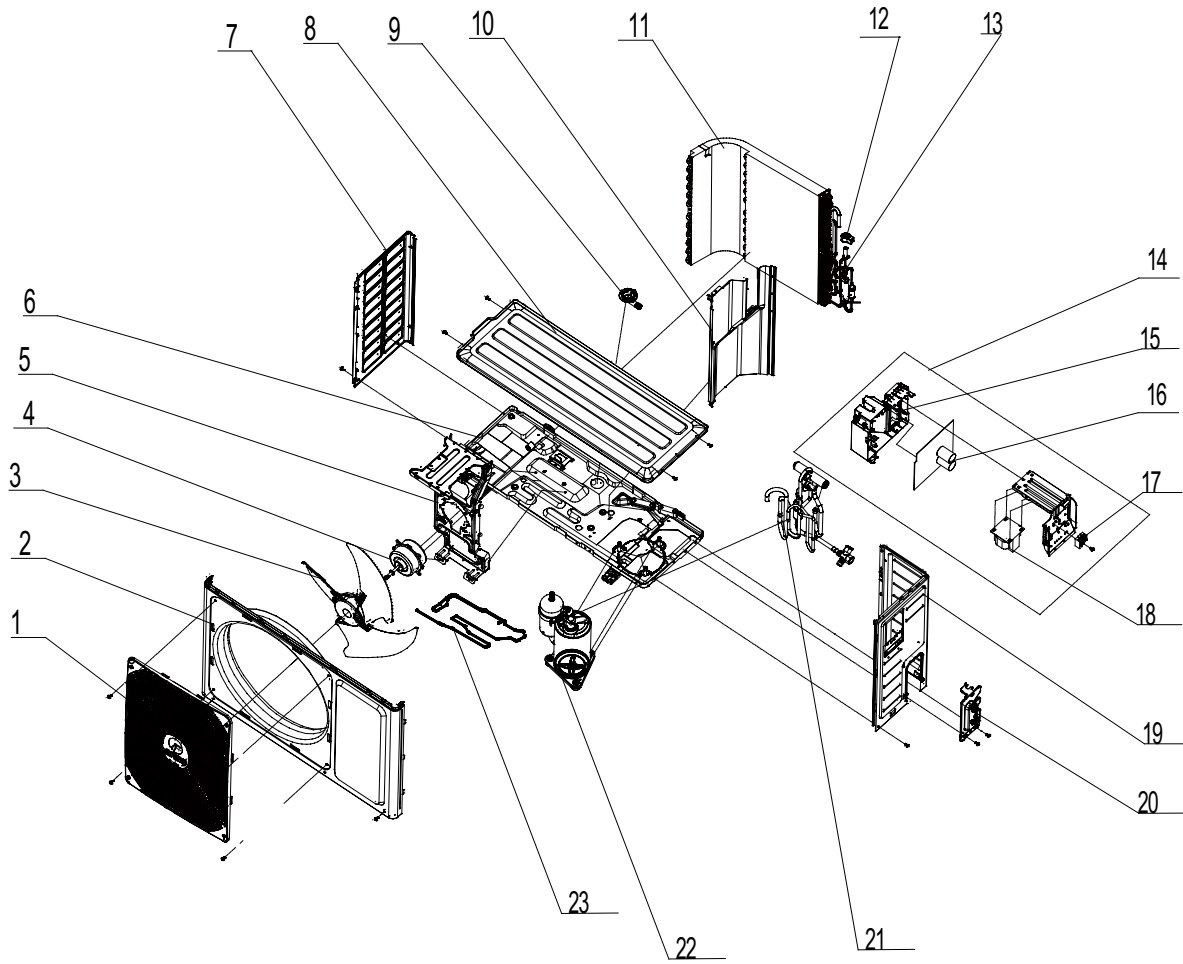

The component picture is only for reference please refer to the actual product.

18K

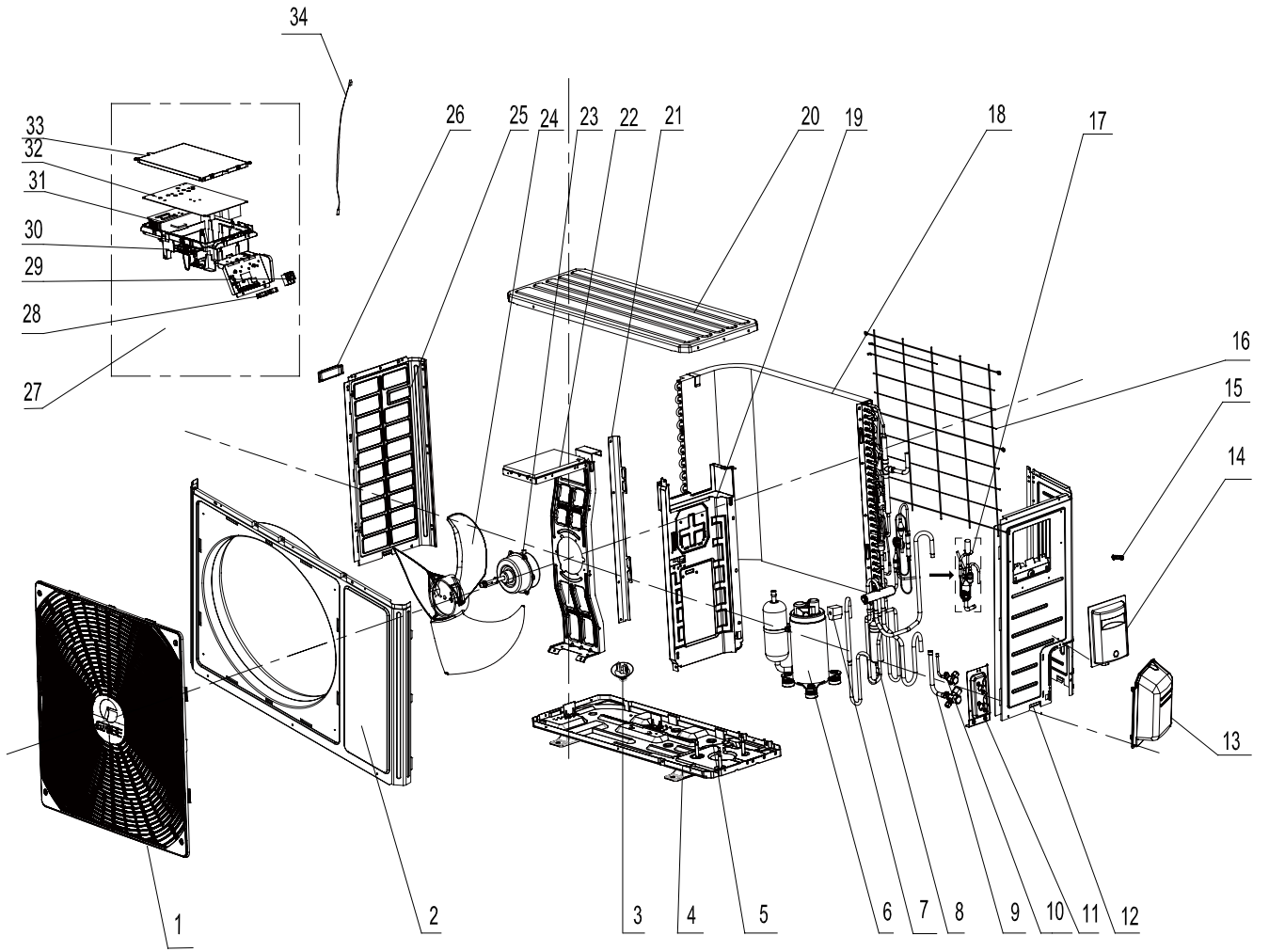

The component picture is only for reference please refer to the actual product.

NO.	Description	Part Code	Qty
		GWH18AKC-K6DNA1A/O	
		Product Code	
		CB340W00300	
1	Front Grill	22413045	1
2	Front Panel	01535013P	1
3	Drainage Connector	06123401	1
4	Chassis Sub-assy	01700000161P	1
5	Drainage Joint	06123401	1
6	Compressor and Fittings	00103919G	1
7	4 Way Valve Coil	4300040087	1
8	4-Way Valve Assy	030152060549	1
9	Cut-off valve 1/2(N)	071302392	1
10	Cut off Valve Sub-Assy	07133843	1
11	Valve support assy	0170506601P	1
12	Right Side Plate	0130509001P	1
13	Valve Cover	22245002	1
14	Handle	2623305301	1
15	Wire Clamp	71010003	1
16	Rear Grill	01475020	1
17	Electronic Expansion Valve assy	03017400002801	1
18	Condenser Assy	011002000177	1
19	Clapboard Sub-Assy	01235081	1
20	Coping	012049000007P	1
21	Clapboard Sub-Assy	01235081	1
22	Motor Support Sub-Assy	01705067	1
23	Fan Motor	1501506402	1
24	Axial Flow Fan	10335008	1
25	Left Side Plate	01305093P	1
26	Left handle	2623305301	1
27	Electric Box Assy	100002067526	1
28	Wire Clamp	71010003	1
29	Terminal Board	422000060009	1
30	Electric Box	20113027	1
31	Radiator	49010252	1
32	Main Board	300027061115	1
33	Electric Box Cover	20123028	1
34	Temperature Sensor	3900030902	1



Above data is subject to change without notice.

11. Removal Procedure

⚠ Caution: discharge the refrigerant completely before removal.

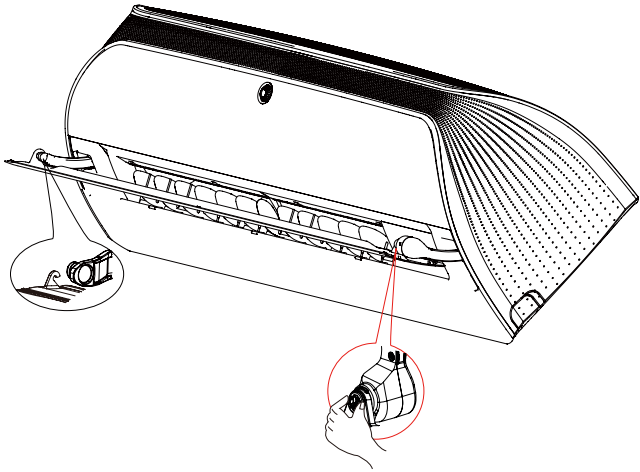
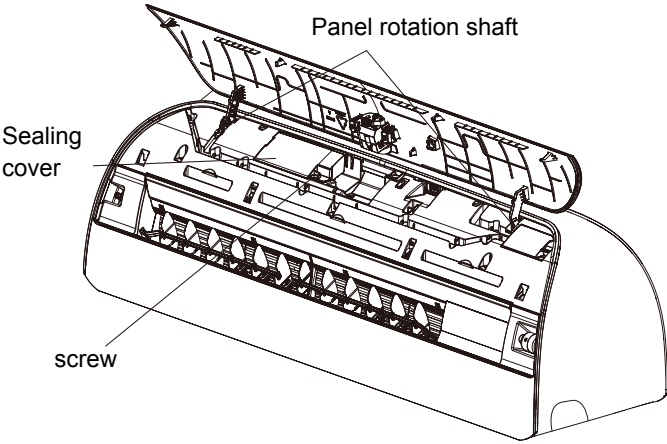
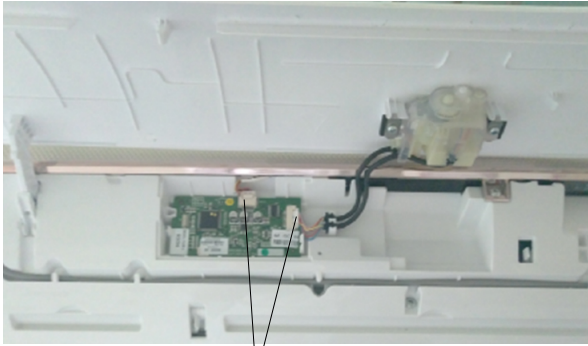
11.1 Removal Procedure of Indoor Unit

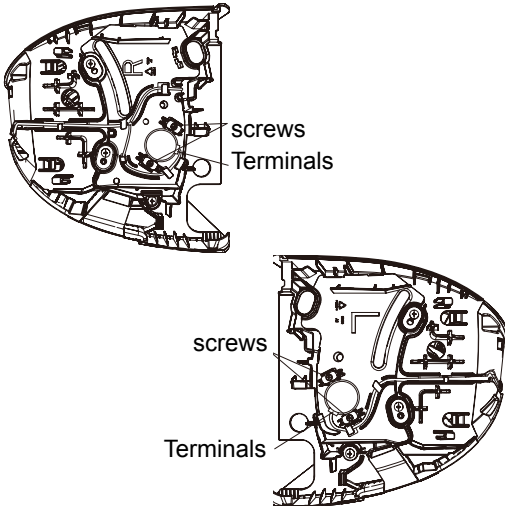
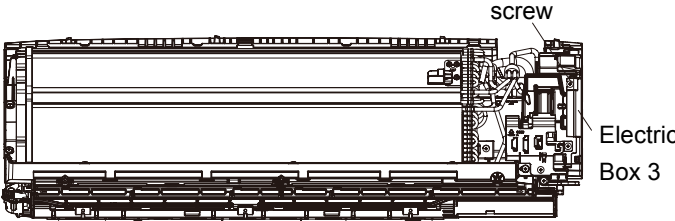
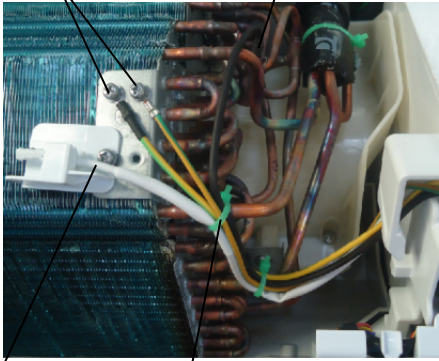
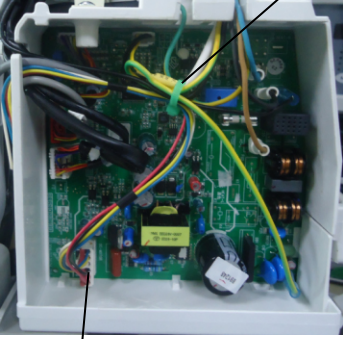
Step	Procedure
1. Remove horizontal louver	
<p>Hold the horizontal louver with two hands and pull out the linkage pole slowly; grasp the linkage pole of left drive box with one hand and grasp the left end of horizontal louver board sub-assy with the other hand; remove the hook with little force, prop up the linkage pole sub-assy with one finger, push the horizontal louver to the left, make the crossed clasp in the linkage pole sub-assy from the crossed groove in the right end of horizontal louver sub-assy to make the horizontal louver separate from the motor shaft.</p>	
2. Remove panel	
<p>Slightly push the panel rotation shaft to separate it from the hole of panel case, and then remove the panel.</p> <p>Loose the screw fixing the sealing cover of I Sense board, and then remove the sealing cover.</p> <p>Pull out the connection wire terminal between boards in the conversion board.</p> <p>Note: after removing the terminal, assemble the sealing cover (I Sense board) to avoid damaging the conversion board due to accidental factors;</p>	  <p>connection wire terminal between boards</p>

Step	Procedure	Procedure
	<p>Remove the screw fixing the left and right drive motor; disconnect the wiring terminal in the motor and then remove the drive motor</p>	
<p>5. Remove electric box assy</p>	<p>Remove the screw fixing electric box 3, Remove the electric box 3.</p> <p>① Cut off the wire binder and pull out the indoor tube temperature sensor. ② Screw off two grounding screw. ③ Remove the room temperature sensor.</p> <p>Remove the wiring terminals of motor, left&right swing motor, up&down swing motor and out-pushing mechanism motor</p>	 <p>Grounding screw Indoor tube temperature sensor</p>  <p>Room temperature sensor Wire binder Terminal of left&right swing motor</p>  <p>Wiring terminal of motor</p>  <p>Terminals of up&down swing motor and out-pushing mechanism motor</p>

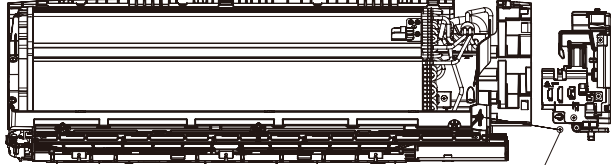
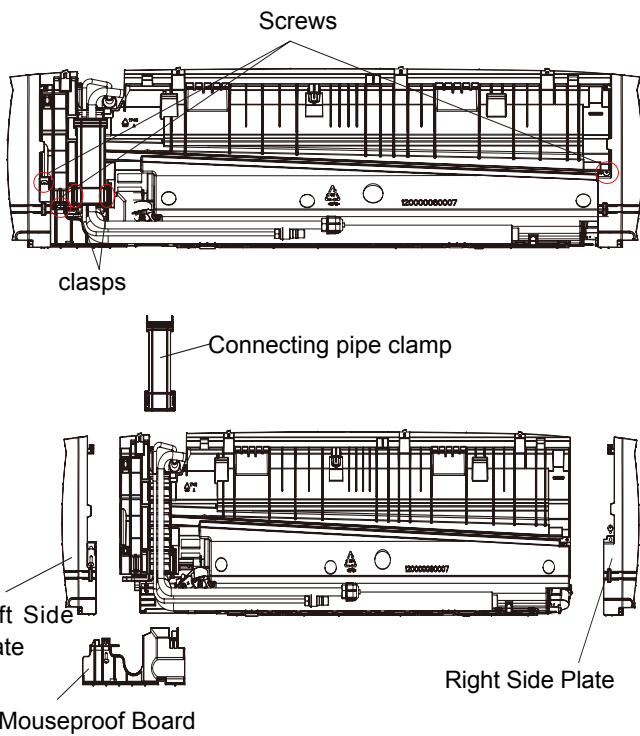
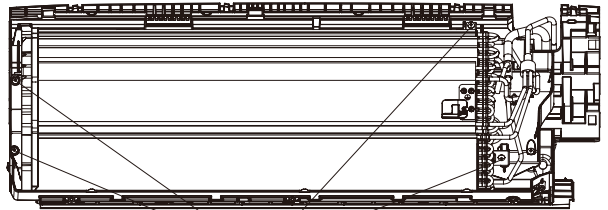
Step	Procedure	Procedure
	<p>Remove the screw fixing electric box assy, Remove the electric box assy.</p>	 <p>Screw</p>
<p>6. Remove rear case assy</p>	<p>Separately remove the screws fixing the left side plate, right side plate and mice-prevention board, and then remove them. Loosen the clasp of connection pipe clamp and then remove the connection pipe clamp.</p>	 <p>Screws</p> <p>clasp</p> <p>Connecting pipe clamp</p> <p>Left Side Plate</p> <p>Mouseproof Board</p> <p>Right Side Plate</p>
	<p>Remove the screw fixing the evaporator; push the motor clamp rightwards to separate the clasp in motor clamp; slightly adjust the evaporator inlet and outlet pipe, and then lift the evaporator upwards to remove it.</p>	 <p>Screws</p>

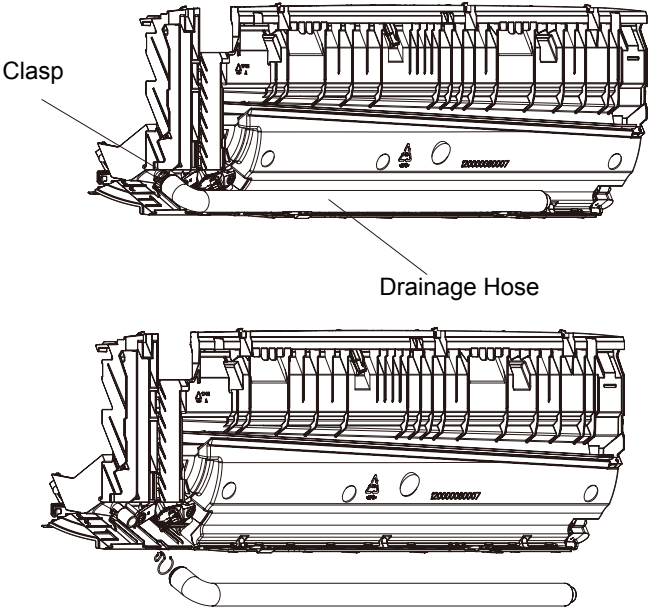
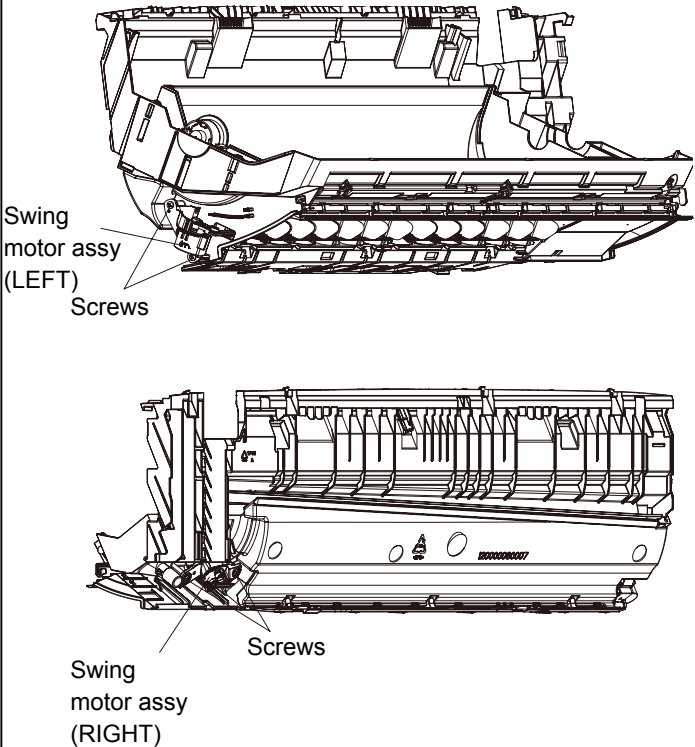
Step	Procedure
8.Remove drain hose	<p data-bbox="233 334 781 438">Clockwisely rotate the hook in the drain pipe, make the hook separate from the bottom plastic pole and then pull out the drain pipe.</p>  <p data-bbox="803 334 868 362">Clasp</p> <p data-bbox="1182 548 1344 576">Drainage Hose</p>
9. Remove Swing motor	<p data-bbox="233 1050 769 1116">Loosen the screws fixing the left/right swing motor and then remove the swing motor.</p>  <p data-bbox="784 1181 906 1279">Swing motor assy (LEFT)</p> <p data-bbox="850 1275 932 1303">Screws</p> <p data-bbox="850 1640 972 1727">Swing motor assy (RIGHT)</p> <p data-bbox="1029 1613 1110 1642">Screws</p>

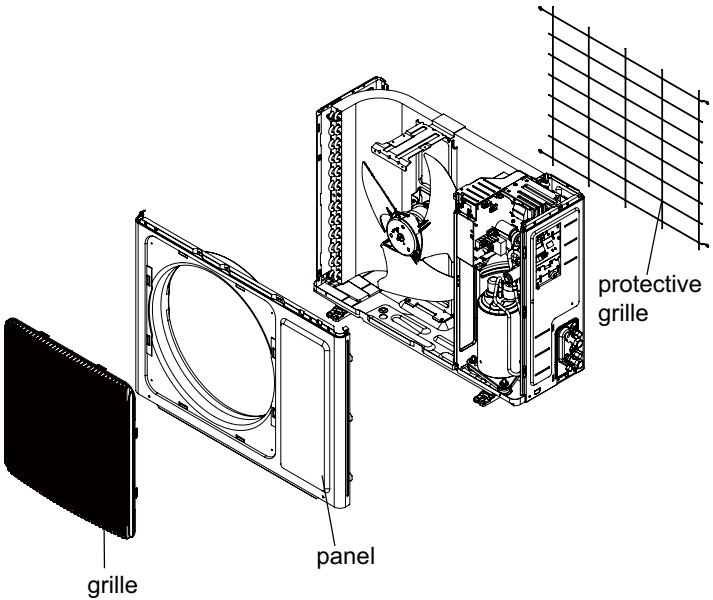
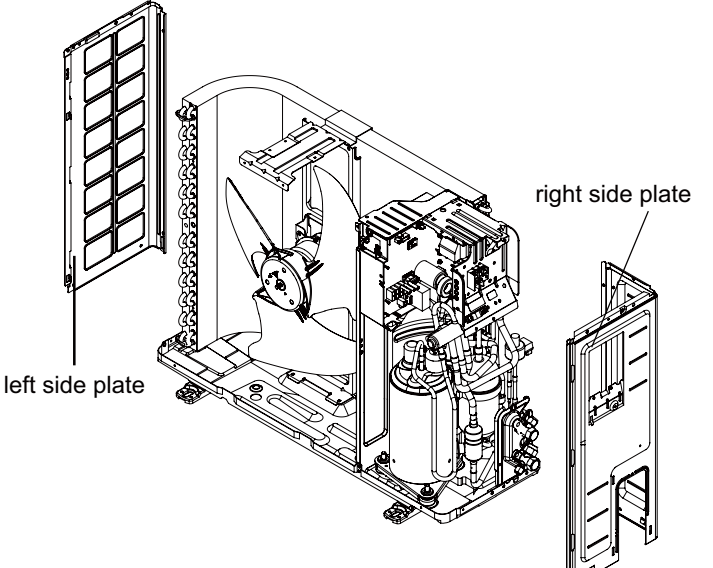
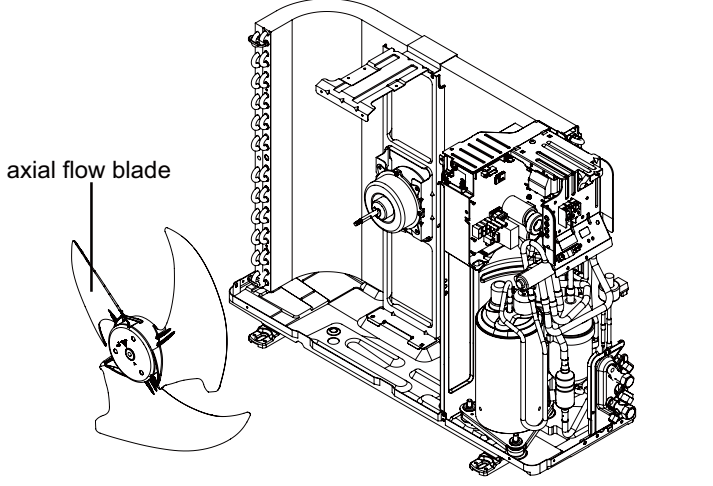
Step	Procedure
<p>3.Remove grille 、 protective grille and front panel</p>	<p>Remove connection screws between the front grille and the front panel. Then remove the front grille. Remove connection screws connecting the front panel with the chassis and the motor support, and then remove the front panel. Remove the screws fixing protective grille and then remove the protective grille.</p> 
<p>4.Remove right side plate、 left side plate</p>	<p>Remove the screws fixing right side plate、 left side plate and then remove them.</p> 
<p>5.Remove axial flow blade</p>	<p>Remove the nut fixing the blade and then remove the axial flow blade.</p> 

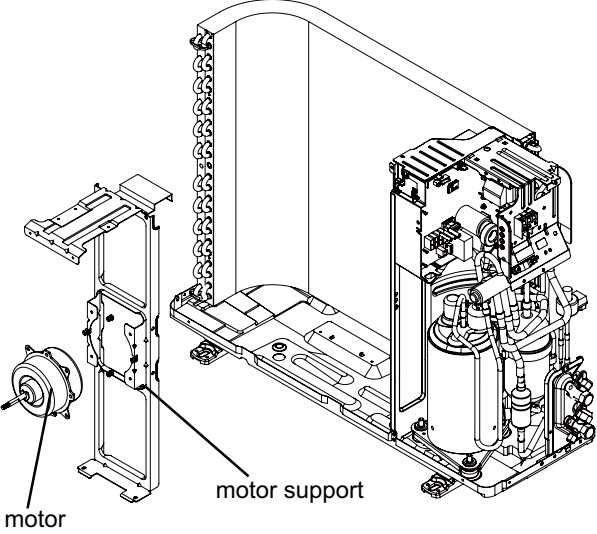
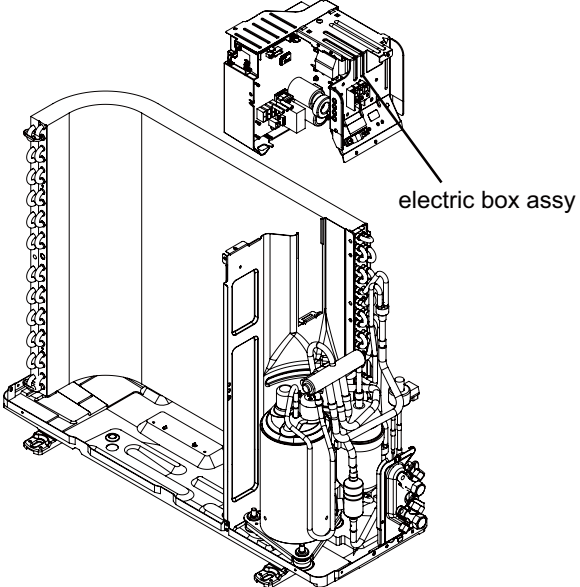
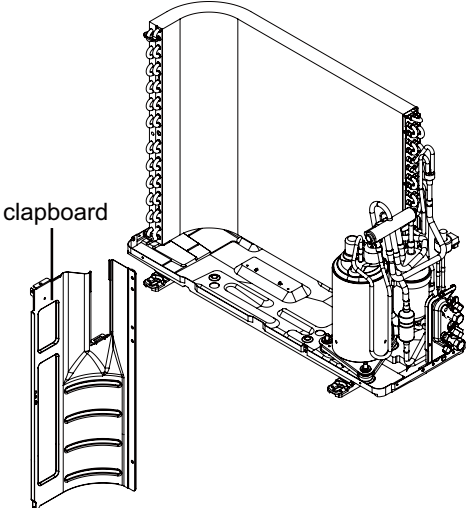
Step	Procedure
<p>6.Remove motor and motor support</p>	<p>Remove the screws fixing motor and then remove the motor. Remove the screws fixing motor support and then remove the motor support.</p> 
<p>7.Remove electric box assy</p>	<p>Remove the screws fixing electric box assy; cut off the tieline; pull out each wiring terminal; lift the electric box assy upwards to remove it. Note: When pulling out the wiring terminal, pay attention to loose the clasp and don't pull it so hard.</p> 
<p>8.Remove clapboard</p>	<p>Remove the screws fixing clapboard and then remove the clapboard.</p> 

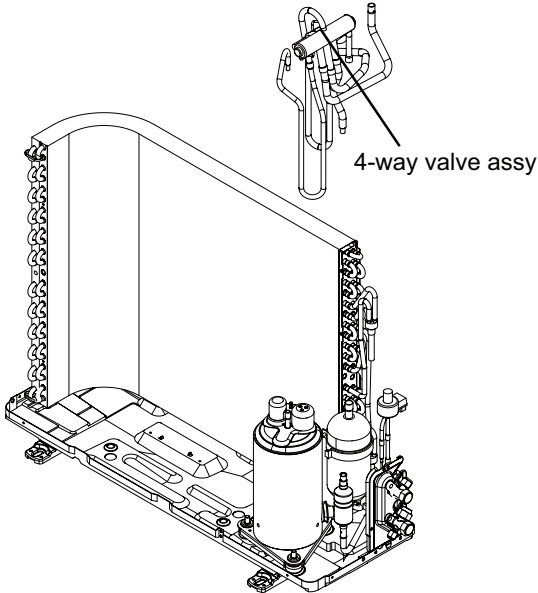
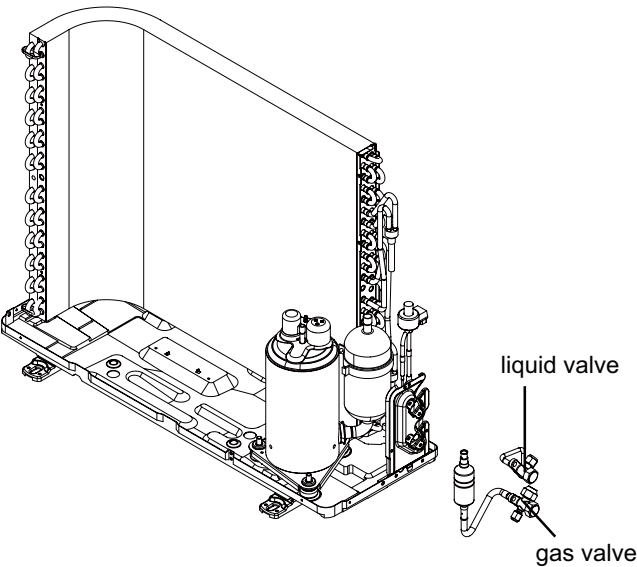
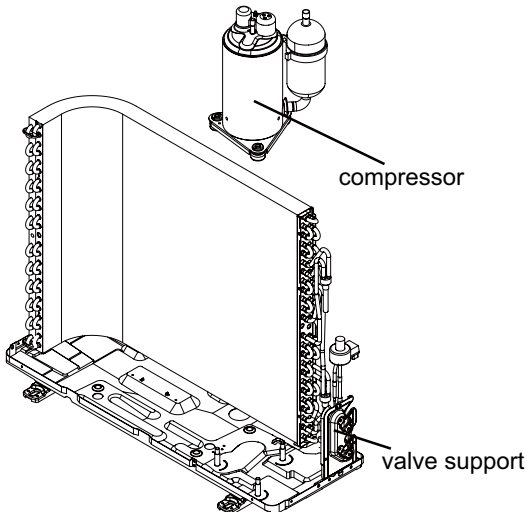
Step	Procedure
<p>9.Remove 4-way valve assy</p>	<p>Unsolder the welding joints connecting the 4-way valve assy with capillary sub-assy, compressor and condenser; remove the 4-way valve.</p> <p>Note: Before unsoldering the welding joint, wrap the 4-way valve with a wet cloth completely to avoid damage to the valve caused by high temperature.</p> 
<p>10.Remove liquid valve and gas valve</p>	<p>Unsolder the welding joint connecting the valve with capillary and condenser; unsolder the welding joint connecting the gas valve and air-return pipe; remove the 2 screws fixing the gas valve to remove the gas valve.</p> <p>Unsolder the welding joint connecting the liquid valve and Y-shaped pipe; remove the 2 screws fixing the liquid valve to remove the liquid valve.</p> <p>Note: Before unsoldering the welding joint, wrap the gas valve with a wet cloth completely to avoid damage to the valve caused by high temperature.</p> 
<p>11.Remove compressor</p>	<p>Remove the 3 footing screws of the compressor and remove the compressor.</p> <p>Remove the screws fixing valve support and then remove the valve support.</p> 

Warning: Be sure to wait for a minimum of 20 minutes after turning off all power supplies and discharge the refrigerant completely before removal.

18K

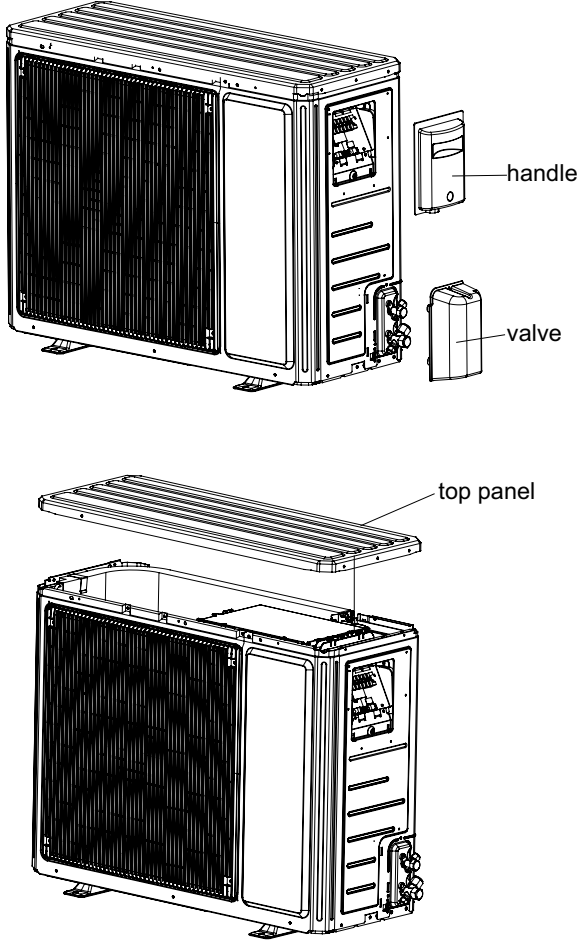
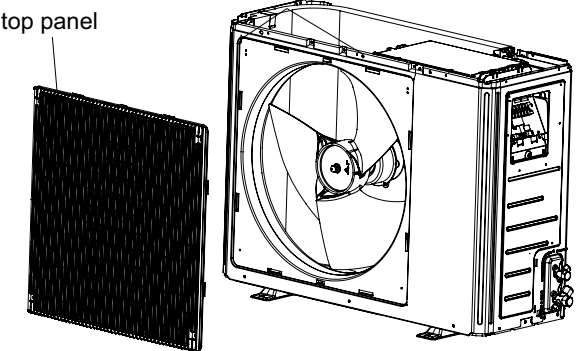
Steps	Procedure
1. Remove top panel	<p data-bbox="126 497 760 580">a Twist off the screws used for fixing the handle and valve cover, pull the handle and valve cover upward to remove it.</p> <p data-bbox="126 1006 760 1116">b Remove the 3 screws connecting the top panel with the front panel and the right side plate, and then remove the top panel.</p>  <p>The diagram illustrates the removal of the top panel in two stages. In the first stage, the handle and valve cover are shown being removed from the top of the unit. In the second stage, the top panel is shown being lifted off the main unit, revealing the internal components.</p>
2. Remove grille, panel and rear grill	<p data-bbox="126 1651 760 1716">a Remove the 2 screws connecting the grille and the panel, and then remove the grille.</p>  <p>The diagram illustrates the removal of the grille. The top panel is shown being removed from the main unit, revealing the fan and internal components. The grille is shown being removed from the front panel.</p>

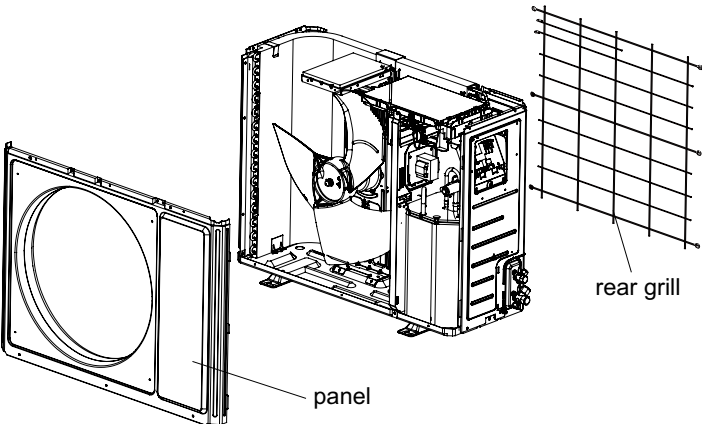
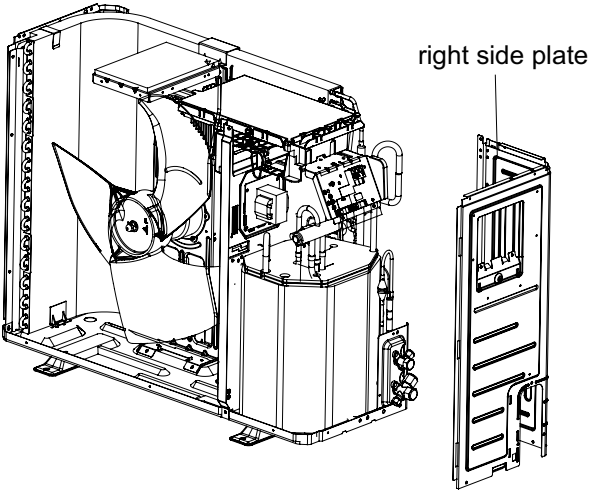
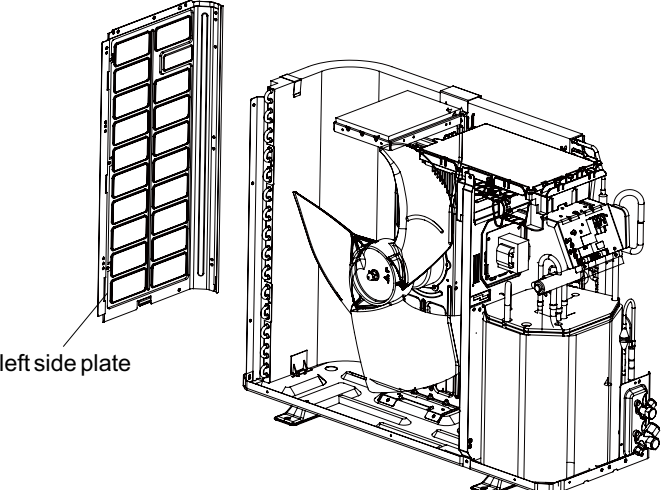
Steps	Procedure	
<p>b</p>	<p>Remove the 5 screws connecting the panel with the chassis and the motor support, and then remove the panel.</p> <p>Remove the 6 screws connecting the left side plate and right side plate and then remove rear grill</p>	 <p>Diagram illustrating the removal of the front panel and rear grill. The front panel is shown detached from the chassis. The rear grill is shown as a separate grid component.</p>
<p>3. Remove left side plate and right side plate</p>		
<p>a</p>	<p>Remove the screws connecting the right side plate with the chassis, the valve support and the electric box, and then remove the right side plate assy.</p>	 <p>Diagram illustrating the removal of the right side plate. The right side plate is shown detached from the chassis.</p>
<p>b</p>	<p>Remove the screws connecting the left side plate and the chassis, and then remove the left side plate assy.</p>	 <p>Diagram illustrating the removal of the left side plate. The left side plate is shown detached from the chassis.</p>

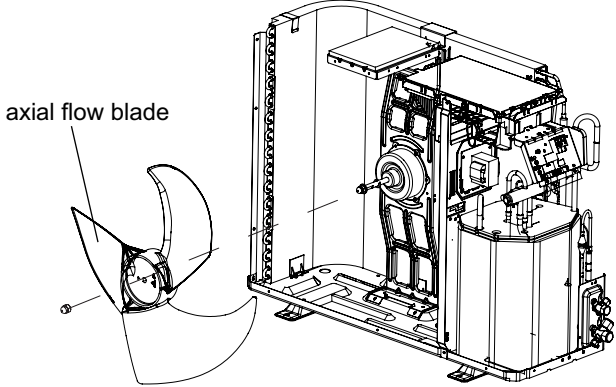
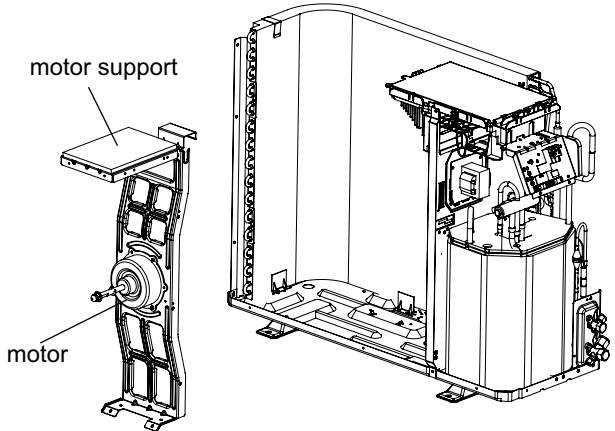
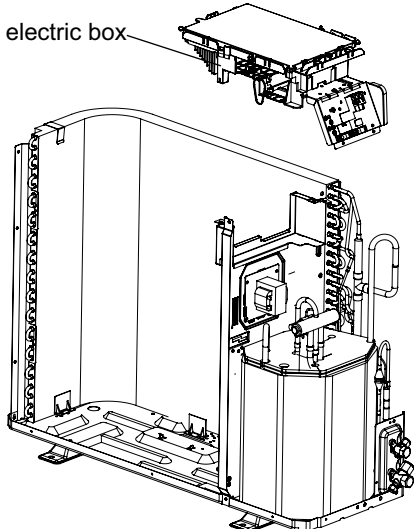
Steps	Procedure
<p>4. Remove fan motor</p>	<p>a Remove the nuts fixing the blade and then remove the axial flow blade.</p>  <p>axial flow blade</p> <p>b Remove the 4 tapping screws fixing the motor; disconnect the leading wire insert of the motor and then remove the motor. Remove the 2 tapping screws fixing the motor support and then pull the motor support upwards to remove it.</p>  <p>motor support</p> <p>motor</p>
<p>5. Remove electric box</p>	<p>Remove the screws fixing the electric box sub-assy; loosen the wire bundle; pull out the wiring terminals and then pull the electric box upwards to remove it.</p>  <p>electric box</p>

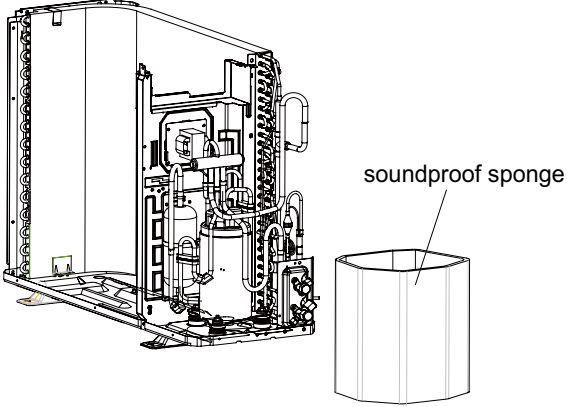
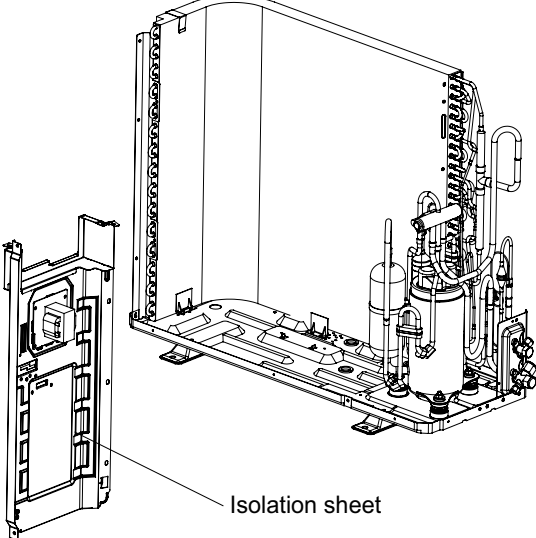
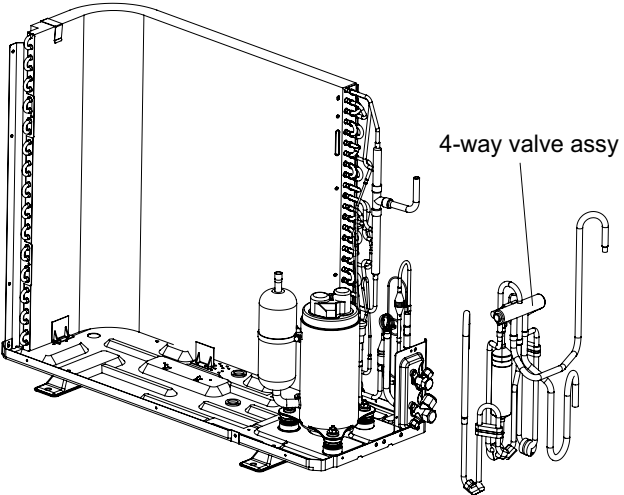
Steps	Procedure
<p>6.Remove soundproof sponge</p>	<p>Since the piping ports on the soundproof sponge are torn easily, remove the soundproof sponge carefully</p> 
<p>7. Remove Isolation sheet</p>	<p>Remove the 3 screws fixing the isolation sheet and then remove the Isolation sheet.</p> 
<p>8. Remove 4-way valve assy</p>	<p>Discharge the refrigerant completely;unsolder the pipelines connecting the compressor and the condenser assy,and then remove the 4-way valve assy.</p> 

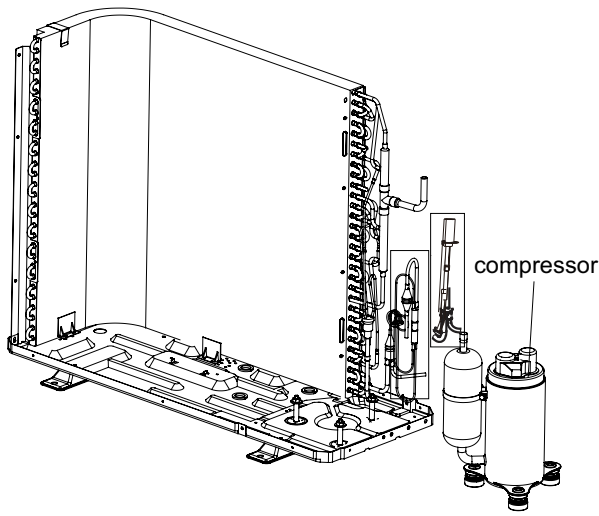
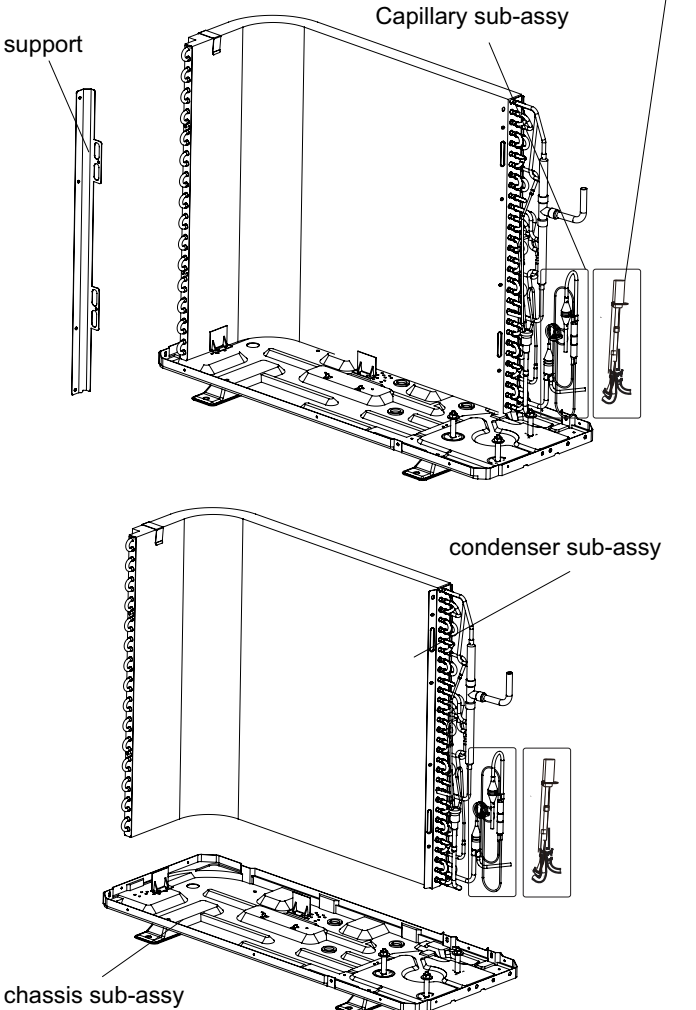
Steps	Procedure
9. Remove compressor	<p data-bbox="235 447 722 513">Remove the 3 foot nuts fixing the compressor and then remove the compressor.</p> 
10. Remove condenser sub-assy	<p data-bbox="138 960 706 1048">a Remove the screws connecting the support (condenser) and condenser assy, and then remove the support (condenser).</p> <p data-bbox="138 1452 722 1517">b Remove the chassis sub-assy and condenser sub-assy.</p> 

Appendix:

Appendix 1: Reference Sheet of Celsius and Fahrenheit

Conversion formula for Fahrenheit degree and Celsius degree: $T_f = T_c \times 1.8 + 32$

Set temperature

Fahrenheit display temperature (°F)	Fahrenheit (°F)	Celsius (°C)	Fahrenheit display temperature (°F)	Fahrenheit (°F)	Celsius (°C)	Fahrenheit display temperature (°F)	Fahrenheit (°F)	Celsius (°C)
61	60.8	16	69/70	69.8	21	78/79	78.8	26
62/63	62.6	17	71/72	71.6	22	80/81	80.6	27
64/65	64.4	18	73/74	73.4	23	82/83	82.4	28
66/67	66.2	19	75/76	75.2	24	84/85	84.2	29
68	68	20	77	77	25	86	86	30

Ambient temperature

Fahrenheit display temperature (°F)	Fahrenheit (°F)	Celsius (°C)	Fahrenheit display temperature (°F)	Fahrenheit (°F)	Celsius (°C)	Fahrenheit display temperature (°F)	Fahrenheit (°F)	Celsius (°C)
32/33	32	0	55/56	55.4	13	79/80	78.8	26
34/35	33.8	1	57/58	57.2	14	81	80.6	27
36	35.6	2	59/60	59	15	82/83	82.4	28
37/38	37.4	3	61/62	60.8	16	84/85	84.2	29
39/40	39.2	4	63	62.6	17	86/87	86	30
41/42	41	5	64/65	64.4	18	88/89	87.8	31
43/44	42.8	6	66/67	66.2	19	90	89.6	32
45	44.6	7	68/69	68	20	91/92	91.4	33
46/47	46.4	8	70/71	69.8	21	93/94	93.2	34
48/49	48.2	9	72	71.6	22	95/96	95	35
50/51	50	10	73/74	73.4	23	97/98	96.8	36
52/53	51.8	11	75/76	75.2	24	99	98.6	37
54	53.6	12	77/78	77	25			

Appendix 2: Configuration of Connection Pipe

- Standard length of connection pipe (More details please refer to the specifications)
- Min length of connection pipe
For the unit with standard connection pipe of 5m, there is no limitation for themin length of connection pipe. For the unit with standard connection pipe of 7.5m and 8m, the min length of connection pipe is 3m.
- Max length of connection pipe (More details please refer to the specifications)
- The additional refrigerant oil and refrigerant charging required after prolonging connection pipe
 - After the length of connection pipe is prolonged for 10m at the basis of standard length, you should add 5ml of refrigerant oil for each additional 5m of connection pipe.
 - The calculation method of additional refrigerant charging amount (on the basis of liquid pipe):
 - Basing on the length of standard pipe, add refrigerant according to the requirement as shown in the table. The additional refrigerant charging amount per meter is different according to the diameter of liquid pipe. See Sheet 2.
 - Additional refrigerant charging amount = prolonged length of liquid pipe X additional refrigerant charging amount per meter

Diameter of connection pipe		Indoor unit throttle	Outdoor unit throttle	
Liquid pipe	Gas pipe	Cooling only, cooling and heating (g / m)	Cooling only (g / m)	Cooling and heating (g / m)
Φ6	Φ9.5 or Φ12	16	12	16
Φ6 or Φ9.5	Φ16 or Φ19	40	12	40
Φ12	Φ19 or Φ22.2	80	48	96
Φ16	Φ25.4 or Φ31.8	136	24	96
Φ19	/	200	200	200
Φ22.2	/	280	280	280

Note: The additional refrigerant charging amount in Sheet 2 is recommended value, not compulsory.

Appendix 3: Pipe Expanding Method

Note:

Improper pipe expanding is the main cause of refrigerant leakage. Please expand the pipe according to the following steps:

A: Cut the pipe

- Confirm the pipe length according to the distance of indoor unit and outdoor unit.
- Cut the required pipe with pipe cutter.

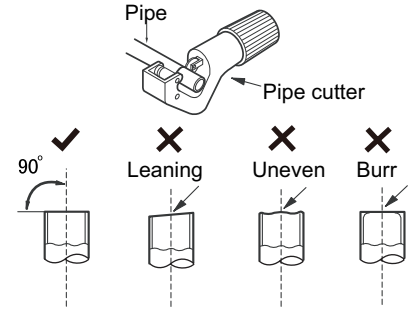

B: Remove the burrs

- Remove the burrs with shaper and prevent the burrs from getting into the pipe.

C: Put on suitable insulating pipe

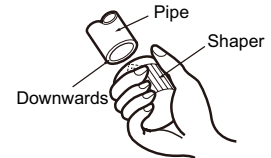

D: Put on the union nut

- Remove the union nut on the indoor connection pipe and outdoor valve; install the union nut on the pipe.

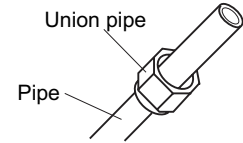

E: Expand the port

- Expand the port with expander.

Note:

- "A" is different according to the diameter, please refer to the sheet below:

Outer diameter(mm)	A(mm)	
	Max	Min
Φ6 - 6.35 (1/4")	1.3	0.7
Φ9.52 (3/8")	1.6	1.0
Φ12 - 12.70 (1/2")	1.8	1.0
Φ16 - 15.88 (5/8")	2.4	2.2

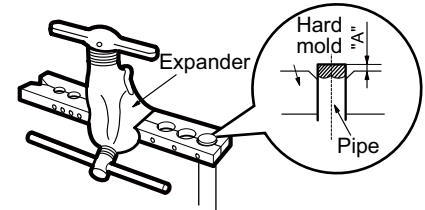

F: Inspection

- Check the quality of expanding port. If there is any blemish, expand the port again according to the steps above.

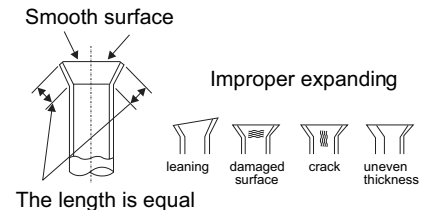

Appendix 4: List of Resistance for Temperature Sensor

Resistance Table of Ambient Temperature Sensor for Indoor and Outdoor Units(15K)

Temp(°C)	Resistance(kΩ)	Temp(°C)	Resistance(kΩ)	Temp(°C)	Resistance(kΩ)	Temp(°C)	Resistance(kΩ)
-19	138.10	0	49.02	20	18.75	40	7.97
-18	128.60	2	44.31	22	17.14	42	7.35
-16	115.00	4	40.09	24	15.68	44	6.79
-14	102.90	6	36.32	26	14.36	46	6.28
-12	92.22	8	32.94	28	13.16	48	5.81
-10	82.75	10	29.90	30	12.07	50	5.38
-8	74.35	12	27.18	32	11.09	52	4.99
-6	66.88	14	24.73	34	10.20	54	4.63
-4	60.23	16	22.53	36	9.38	56	4.29
-2	54.31	18	20.54	38	8.64	58	3.99

Resistance Table of Tube Temperature Sensors for Indoor and Outdoor (20K)

Temp(°C)	Resistance(kΩ)	Temp(°C)	Resistance(kΩ)	Temp(°C)	Resistance(kΩ)	Temp(°C)	Resistance(kΩ)
-19	181.40	20	25.01	60	4.95	100	1.35
-15	145.00	25	20.00	65	4.14	105	1.16
-10	110.30	30	16.10	70	3.48	110	1.01
-5	84.61	35	13.04	75	2.94	115	0.88
0	65.37	40	10.62	80	2.50	120	0.77
5	50.87	45	8.71	85	2.13	125	0.67
10	39.87	50	7.17	90	1.82	130	0.59
15	31.47	55	5.94	95	1.56	135	0.52

Resistance Table of Discharge Temperature Sensor for Outdoor(50K)

Temp(°C)	Resistance(kΩ)	Temp(°C)	Resistance(kΩ)	Temp(°C)	Resistance(kΩ)	Temp(°C)	Resistance(kΩ)
-30	911.400	10	98	50	17.65	90	4.469
-25	660.8	15	77.35	55	14.62	95	3.841
-20	486.5	20	61.48	60	12.17	100	3.315
-15	362.9	25	49.19	65	10.18	105	2.872
-10	274	30	39.61	70	8.555	110	2.498
-5	209	35	32.09	75	7.224	115	2.182
0	161	40	26.15	80	6.129	120	1.912
5	125.1	45	21.43	85	5.222	125	1.682

JF00304281



GREE ELECTRIC APPLIANCES, INC. OF ZHUHAI

Add: West Jinji Rd, Qianshan, Zhuhai, Guangdong, China, 519070

Tel: (+86-756) 8522218

Fax: (+86-756) 8669426

E-mail: gree@gree.com.cn www.gree.com

HONG KONG GREE ELECTRIC APPLIANCES SALES LIMITED

Add: Unit 2612, 26/F., Miramar Tower 132 Nathan Road, TST, Kowloon, HK

Tel: (852) 31658898 Fax: (852) 31651029

For product improvement, specifications and appearance in this manual are subject to change without prior notice.