

## Speicher, indirekt beheizt (GWSi)

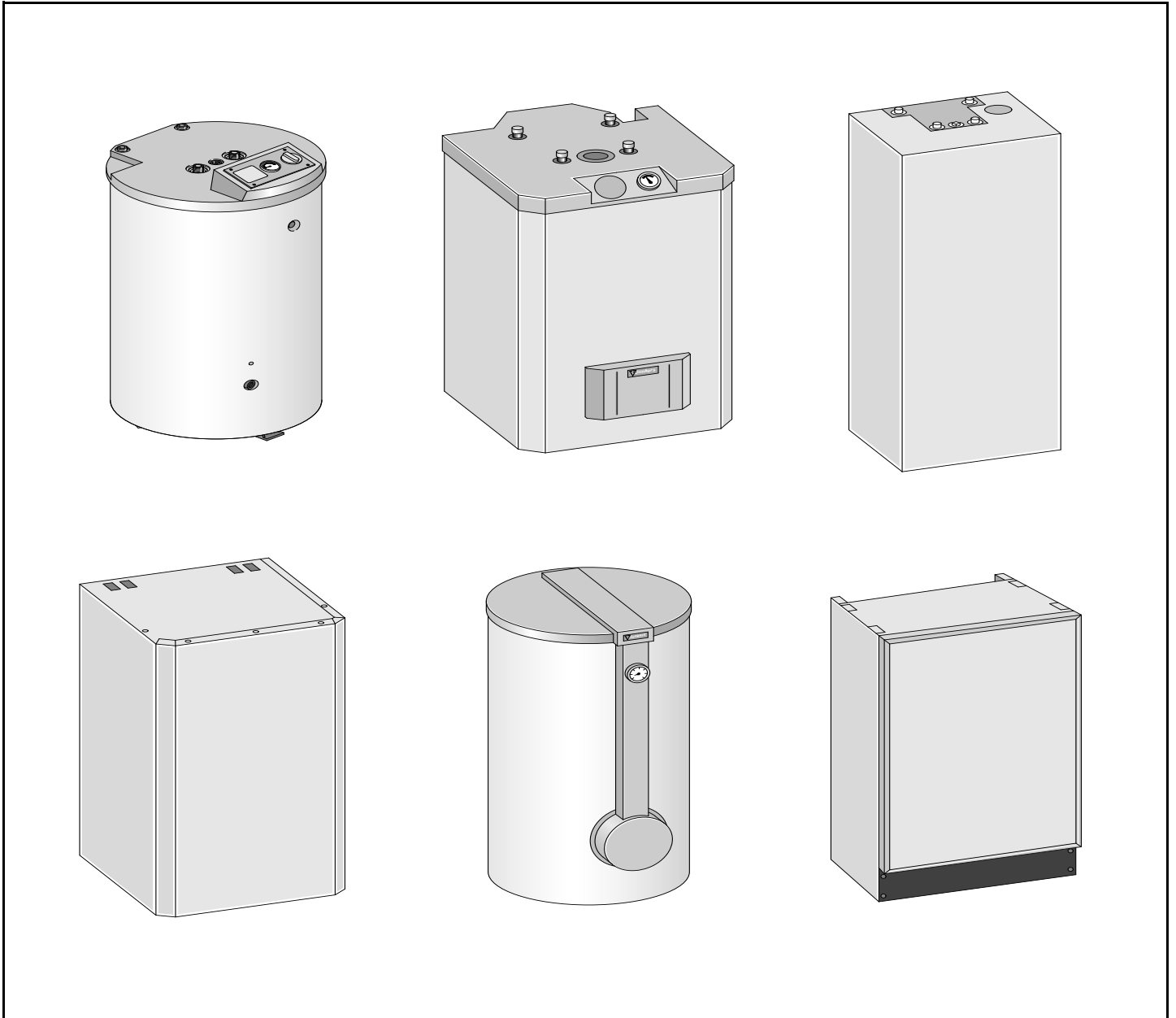



Deutsch

### **Wichtige Hinweise**

Ersatzteile dürfen nur von einem zugelassenen Installateur eingebaut werden!

English

### **Important notes**

The spare parts may only be installed by an approved installer!

Français

### **Indications importantes**

L'installation des pièces de rechange doit être effectuée par un professionnel qualifié!

Português

### **Informações importantes**

Peças de substituição só podem ser montadas por um técnico credenciado!

### **Avvertenze importanti**

Le parti di ricambio possono essere montate esclusivamente da personale qualificato ed in possesso dei requisiti tecnico-professionali!

Italiano

### **Indicaciones importantes**

Los repuestos solamente deben ser montados por los servicios técnicos oficiales de la marca!

Español

### **Belangrijke aanwijzing**

Onderdelen mogen alleen door een erkend installateur worden vervangen!

Nederlands

### **Önemli Bilgiler**

Yedek parçalar sadece yetkili tesisatçılar tarafından monte edilebilir!

Türkçe

**Inhaltsverzeichnis**  
**Table of contents****Table de matieres**  
**Indice****Inhoud**  
**Indice**

1_ST120-1EBS0400/C1	7 719 001 576	8
BOSCH UNIT 100L	7 719 002 339	9
CERA 85L	7 719 002 332	10
CERA 110L	7 719 002 338	11
CERAPUR 55L	7 719 002 333	12
CERAPUR 65L	7 719 002 336	13
CERAPUR 85L	7 719 002 334	14
EUROPUR 65L	7 719 002 335	15
HRVS120	7 719 002 081	16
HRVS160	7 719 002 082	17
P 500-80 S	7 719 003 036	18
P 500-120 S	7 719 003 039	19
P 750-80 S	7 719 003 037	20
P 750-120 S	7 719 003 040	21
P 1000-80 S	7 719 003 038	22
P 1000-120 S	7 719 003 041	23
SE 120	7 719 002 319	24
SE 150-1	7 719 003 272	25
SE 200-1	7 719 003 273	26
SE 300-1	7 719 003 274	27
SE120-1	7 719 003 271	28
SE150C1	7 719 002 320	29
SE150C2	7 719 002 323	30
SE200C1	7 719 002 321	31
SE200C2	7 719 002 324	32
SE300C1	7 719 002 322	33
SE300C2	7 719 002 325	34
SK 120-4 ZB	7 719 001 931	35
SK 130-2 E	7 719 001 923	36
SK 130-2 E/C 2	7 719 002 038	37
SK 160-4 ZB	7 719 001 932	38
SK 200-4 ZB	7 719 001 933	39
SK 300 SOLAR	7 719 001 372	40
SK 300-1 SOLAR	7 719 001 929	41
SK 300-1 solar	8 718 541 087	42
SK 300-1 SOLAR/C 2	7 719 002 125	43
SK 300-3 ZB	7 719 001 369	44
SK 400-1 SOLAR	7 719 001 930	45
SK 400-1 solar	8 718 541 090	46
SK 400-1 SOLAR/C 2	7 719 002 126	47
SK 400-3 ZB	7 719 001 370	48
SK 500-1 SOLAR	7 739 300 188	49
SK 500-1 SOLAR/C 2	7 739 300 300	50
SK 500-3 ZB	7 719 001 371	51
SK 800 ZB	7 719 001 676	52
SK 1000 ZB	7 719 001 675	53
SK90-2	7 719 000 391	54
SK120-4ZB/C2	7 719 002 119	56
SK130-1E	7 719 001 211	57
SK130-2R	7 719 000 394	58

**Inhaltsverzeichnis**  
**Table of contents**

**Table de matieres**  
**Indice**

**Inhoud**  
**Indice**

SK130-2W	7 719 000 392	59
SK130-2Z	7 719 000 646	60
SK130-2ZB	7 719 000 786	61
SK130-3ZB	7 719 000 958	62
SK130-3ZBS3500	7 719 001 460	63
SK130E	7 719 000 991	64
SK160-4ZB/C2	7 719 002 120	65
SK160-4ZBS3500	7 719 002 074	66
SK180-2R	7 719 000 393	67
SK180-2W	7 719 000 395	68
SK180-2Z	7 719 000 647	69
SK180-2ZB	7 719 000 787	70
SK180-3ZB	7 719 000 959	71
SK180-3ZBS3500	7 719 001 461	72
SK200-4ZB/C2	7 719 002 121	73
SK200-4ZBS3500	7 719 002 075	74
SK220-3ZB	7 719 000 960	75
SK220-3ZBS3500	7 719 001 462	76
SK230-2Z	7 719 000 778	77
SK300-1SOLAR	7 739 300 909	78
SK300-1SOLAR S0800	7 739 300 915	79
SK300-2	7 739 100 138	80
SK300-2Z	7 719 000 648	81
SK300-3ZB	7 719 002 877	82
SK300-3ZB/C2	7 719 002 122	83
SK300-3ZBS0400	7 719 001 583	84
SK300-3ZBS3500	7 719 001 463	85
SK400-1SOLAR	7 739 300 910	86
SK400-3ZB S2800	7 719 002 878	87
SK400-3ZB/C2	7 719 002 123	88
SK400-3ZBS3500	7 719 001 464	89
SK400SOLAR	7 719 001 373	90
SK400SOLARS3500	7 719 001 467	91
SK450-2Z	7 739 100 139	92
SK500-1SOLAR	7 739 300 911	93
SK500-3ZB	7 719 002 879	94
SK500-3ZB	7 747 020 296	95
SK500-3ZB S0400	7 747 020 289	96
SK500-3ZB/C2	7 719 002 124	97
SK500-3ZBS3500	7 719 001 465	98
SK750	7 739 300 913	99
SL 130-1	7 719 001 195	100
SL 130-1/C 2	7 719 002 039	101
SL 200-1	7 719 001 196	102
SL 200-1/C 2	7 719 002 040	103
SL130	7 719 000 905	104
SL200	7 719 000 906	105
SO 120-1	7 719 001 167	106
SO 120-1/C 2	7 719 002 116	107
SO 160-1	7 719 001 168	108

**Inhaltsverzeichnis  
Table of contents****Table de matieres  
Indice****Inhoud  
Indice**

SO 160-1/C 2	7 719 002 117	109
SO 200-1	7 719 001 169	110
SO 200-1/C 2	7 719 002 118	111
SO120	7 719 000 711	112
SO120-1	7 719 002 874	113
SO120-1S3500	7 719 001 448	114
SO160	7 719 000 712	115
SO160-1	7 719 002 875	116
SO160-1B	7 719 001 170	117
SO160-1BS3500	7 719 001 477	118
SO160-1S3500	7 719 001 449	119
SO160B	7 719 000 776	120
SO200	7 719 000 713	121
SO200-1	7 719 002 876	122
SO200-1B	7 719 001 171	123
SO200-1BS3500	7 719 001 478	124
SO200-1S3500	7 719 001 450	125
SO200B	7 719 000 777	126
SP 750 SOLAR	7 739 300 114	127
SP750 SOLAR S5800	7 739 300 912	128
ST 50-5	7 719 001 550	129
ST 65 E	7 719 003 009	130
ST 75	7 719 001 406	131
ST 80-5	7 719 001 551	132
ST 90-3 E	7 719 001 542	133
ST 120-1 E	7 719 002 029	134
ST 120-1 Z	7 719 002 035	135
ST 120-2 E	7 719 002 721	136
ST 120-2 E	7 719 003 064	137
ST 160-1 E	7 719 002 030	138
ST 160-1 EO/C1	7 719 001 396	139
ST 160-2 E	7 719 002 722	140
ST 160-2 E	7 719 003 065	141
ST50-2	7 719 000 638	142
ST50-3	7 719 000 863	143
ST50-4	7 719 001 079	144
ST50ES	7 719 001 977	145
ST65E	7 719 003 014	146
ST75	7 719 002 870	147
ST75ES	7 719 001 978	148
ST75S0200	7 719 002 092	149
ST75S0400	7 719 001 640	150
ST80-3	7 719 000 864	151
ST80-4	7 719 001 080	152
ST90-2/1E	7 719 001 643	153
ST90-2E	7 719 000 771	154
ST90-3E	7 719 002 871	155
ST110E	7 719 001 026	156
ST120	7 719 000 732	157
ST120-1E	7 719 001 311	158

**Inhaltsverzeichnis  
Table of contents****Table de matieres  
Indice****Inhoud  
Indice**

ST120-1E	7 719 002 872	159
ST120-1E S5300	7 719 001 818	160
ST120-1E S5800	7 719 002 448	161
ST120-1EB	7 719 001 312	162
ST120-1EB/C1	7 719 002 096	163
ST120-1EO	7 719 001 364	164
ST120-1EOB	7 719 001 365	165
ST120-1ES0200/C1	7 719 002 093	166
ST120-1ES3500/C1	7 719 001 472	167
ST120-1Z	7 719 001 971	168
ST120-1Z S5300	7 719 002 447	169
ST120-1Z/C1S5800	7 719 002 424	170
ST120-2E	7 719 003 066	171
ST120-2E	7 719 003 068	172
ST120-2E	7 719 003 072	173
ST120-2E	7 719 003 243	174
ST120-2EB	7 719 002 756	175
ST120-2EB	7 719 002 885	176
ST120-2EB	7 719 003 269	177
ST120A	7 719 000 755	178
ST120B	7 719 000 775	179
ST120ES	7 719 001 979	180
ST130-2E	7 719 000 772	181
ST160-1E	7 719 001 313	182
ST160-1E	7 719 002 873	183
ST160-1E S5300	7 719 001 819	184
ST160-1E S5800	7 719 002 449	185
ST160-1EB	7 719 001 314	186
ST160-1EB/C1	7 719 002 097	187
ST160-1EBS0400/C1	7 719 001 577	188
ST160-1ES0200/C1	7 719 002 094	189
ST160-1ES3500/C1	7 719 001 473	190
ST160-2E	7 719 003 067	191
ST160-2E	7 719 003 069	192
ST160-2E	7 719 003 073	193
ST160-2E	7 719 003 244	194
ST160-2EB	7 719 002 757	195
ST160-2EB	7 719 002 886	196
ST160-2EB	7 719 003 270	197
ST160ES	7 719 001 980	198
SU110E	7 719 000 856	199
SW300-1	7 739 100 070	200
TS200	7 739 300 336	201
TYPE 5171 100L	7 719 002 337	202

Ersatzteilliste  
Spare parts list  
Liste des pièces de rechange  
Lista parti di ricambio  
Onderdelenlijst  
Lista de repuestos

# 1\_ST120-1EBS0400/C1 - 7719001576

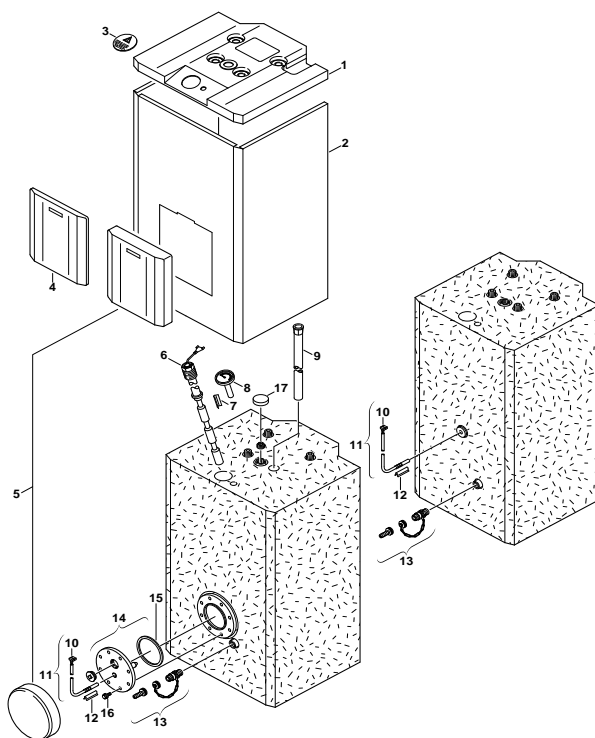

6720901198 AC/G

Pos	Bestell-Nr.	Bezeichnung	Description	Dénomination	Descrizione	Benaming	Descripción	PG
1	8 715 503 369 0	Haube hellgrau	Hood light grey	Carpot gris clair	Coperchio grigio chiaro	DEKSEL ST 120-1E/C1	Capota girar claro	41
2	8 715 401 294 0	Mantel weiß	Outer_case Withe	Outer_case Withe	Outer_case Withe	Outer_case Withe	Outer_case Withe	53
3	8 715 503 372 0	Abdeckung hellgrau	Covering sheet light grey	Couvercle gris clair	Coperchio grigio chiaro	Afdichting lichtgrijs	Chapa de protección girar claro	30
5	8 715 503 368 0	Abdeckung hellgrau	Covering sheet light grey	Couvercle gris clair	Coperchio grigio chiaro	Afdichting lichtgrijs	Chapa de protección girar claro	39
6	8 709 918 666 0	Anode 1"	Anode 1"	Anode 1"	Anodo 1"	ANODE (KETTING) ST120/160-1E /SK 130-3Z	Anodo 1"	43
7	8 714 606 024 0	Klemmfeder	Clamp spring	RESSORT POUR THERMOMETRE	Fermo	KLEMVVEER V/THERMOMETER ST/SO	Muelle fijación	20
8	8 717 208 050 0	Thermometer	Thermometer	Thermomètre	Termometro	Thermometer	Termómetro	31
9	8 710 735 442 0	Einlaufrohr Edelstahl 850mm	Inlet tube stainless steel 850mm	Tube d'arrivée acier spécial 850mm	Tubo della presa acciaio raffinato 850mm	BUIS 850 MM INTERNE BOILERS (INOX)	Pipa del producto acero afinado 850mm	38
10	8 711 006 060 0	Stecker	Plug	Connecteur	Spina	STEKKER NTC-VOELER ST...1E/SK 300/ST 75	Anection	16
11	8 714 500 034 0	Sensor WW-NTC mit Aderendhülse 6m	Temperature sensor 6mm	SONDE DE TEMPERATURE 6mm	Sensore termometrico 6mm	Temperatuurvoeler 6mm	Sensor de temperatura 6mm	34
12	8 714 606 021 0	Klemmfeder	Clamp spring	Ressort	Fermo	KLEMVVEER NTC SK120/140/160-4ZB	Muelle de tecla	25
13	8 738 505 974 0	Ventil	Globe valve	Robinet	Valvola	AFSLUITKRAAN	Válvula de globo	26
14	8 715 503 241 0	Flanschdeckel	Flange cover	Couvercle de bride de racc.	Flangia bollitore	Flensdeksel	Tapa reborde	47
15	8 710 103 096 0	Dichtungs-Set 100x109D - 115/138Dx3 (1x)	Set of seals 100x109D - 115/138Dx3 (1x)	Jeu de joints 100x109D - 115/138Dx3 (1x)	Set guarnizioni 100x109D - 115/138Dx3	DICHTING FLENS SK...2ZB/-3ZB (VANA F 070)	conjunto de juntas 100x109D - 115/138Dx3	23
16	2 911 060 291 0	Schraube M10x25 (10x)	Screw M10x25 (10x)	Vis M10x25 (10x)	Vite M10x25 (10x)	Schroef M10x25 (10x)	Tornillo M10x25 (10x)	18
16	2 911 060 342 0	Schraube M12x30 (10x)	Screw M12x30 (10x)	Vis M12x30 (10x)	Vite M12x30 (10x)	Schroef M12x30 (10x)	Tornillo M12x30 (10x)	16
17	8 715 503 239 0	Isolierung	Insulation	Bouchon	Isolamento	ISOLATIE SK 300-1 SOLAR (7719001929)	Aislamiento	23

For:





Ersatzteilliste  
 Spare parts list  
 Liste des pièces de rechange  
 Lista parti di ricambio  
 Onderdelenlijst  
 Lista de repuestos

# CERA 85L - 7719002332

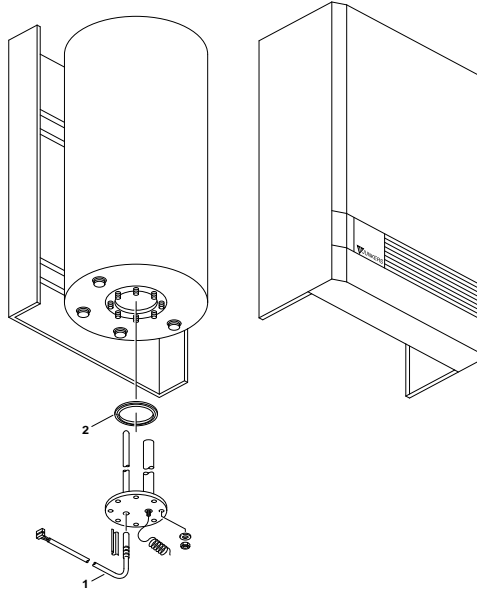

6720904172.AA/G

Pos	Bestell-Nr.	Bezeichnung	Description	Dénomination	Descrizione	Benaming	Descripción	PG
1	8 714 500 034 0	Sensor WW-NTC mit Aderendhülse 6m	Temperature sensor 6mm	SONDE DE TEMPERATURE 6mm	Sensore termometrico 6mm	Temperatuervoeler 6mm	Sensor de temperatura 6mm	34
2	8 710 103 512 0	Dichtung	Washer	Joint	Guarnizione	DICHTING ST 110-E	Junta	19

For:



Ersatzteilliste  
Spare parts list  
Liste des pièces de rechange  
Lista parti di ricambio  
Onderdelenlijst  
Lista de repuestos

# CERAPUR 55L - 7719002333

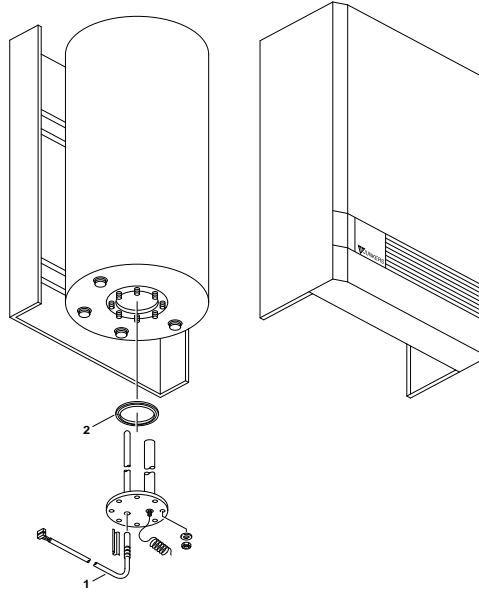

6720904172.AA/G

Pos	Bestell-Nr.	Bezeichnung	Description	Dénomination	Descrizione	Benaming	Descripción	PG
1	8 714 500 034 0	Sensor WW-NTC mit Aderendhülse 6m	Temperature sensor 6mm	SONDE DE TEMPERATURE 6mm	Sensore termometrico 6mm	Temperatuurvoeler 6mm	Sensor de temperatura 6mm	34
2	8 710 103 512 0	Dichtung	Washer	Joint	Guarnizione	DICHTING ST 110-E	Junta	19

For:



Ersatzteilliste  
 Spare parts list  
 Liste des pièces de rechange  
 Lista parti di ricambio  
 Onderdelenlijst  
 Lista de repuestos

# CERAPUR 85L - 7719002334

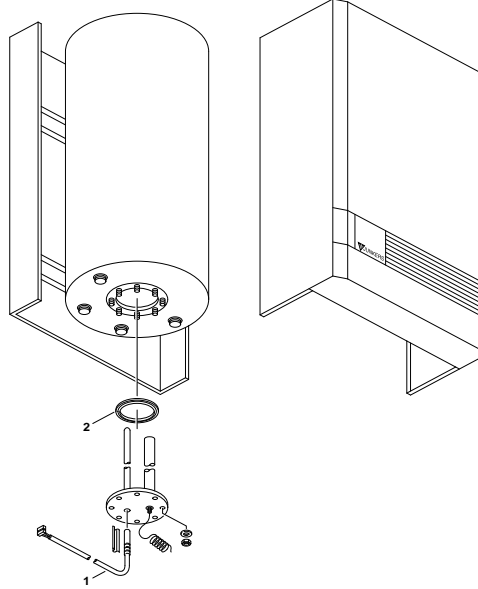

6720904172.AA/G

Pos	Bestell-Nr.	Bezeichnung	Description	Dénomination	Descrizione	Benaming	Descripción	PG
1	8 714 500 034 0	Sensor WW-NTC mit Aderendhülse 6m	Temperature sensor 6mm	SONDE DE TEMPERATURE 6mm	Sensore termometrico 6mm	Temperatuurvoeler 6mm	Sensor de temperatura 6mm	34
2	8 710 103 512 0	Dichtung	Washer	Joint	Guarnizione	DICHTING ST 110-E	Junta	19

For:

**Ersatzteilliste**

Spare parts list

Liste des pièces de rechange

Lista parti di ricambio

Onderdelenlijst

Lista de repuestos

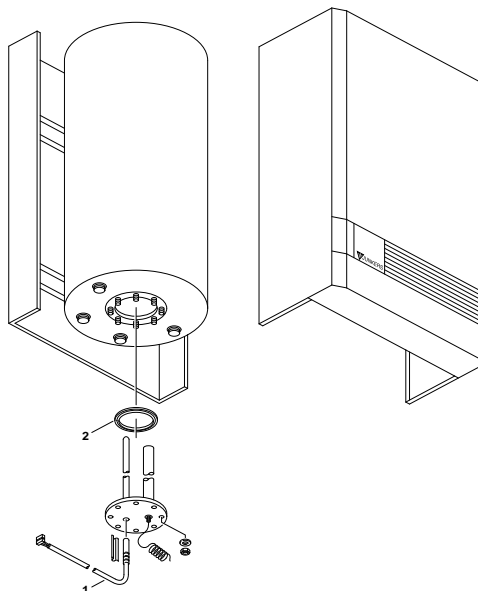
**EUROPUR 65L - 7719002335**

6720904172.AA/G

<b>Pos</b>	<b>Bestell-Nr.</b>	<b>Bezeichnung</b>	<b>Description</b>	<b>Dénomination</b>	<b>Descrizione</b>	<b>Benaming</b>	<b>Descripción</b>	<b>PG</b>
1	<b>8 714 500 034 0</b>	Sensor WW-NTC mit Aderendhülse 6m	Temperature sensor 6mm	SONDE DE TEMPERATURE 6mm	Sensore termometrico 6mm	Temperatuurvoeler 6mm	Sensor de temperatura 6mm	34
2	<b>8 710 103 512 0</b>	Dichtung	Washer	Joint	Guarnizione	DICHTING ST 110-E	Junta	19

For:

Ersatzteilliste  
Spare parts list  
Liste des pièces de rechange  
Lista parti di ricambio  
Onderdelenlijst  
Lista de repuestos

# HRVS120 - 7719002081

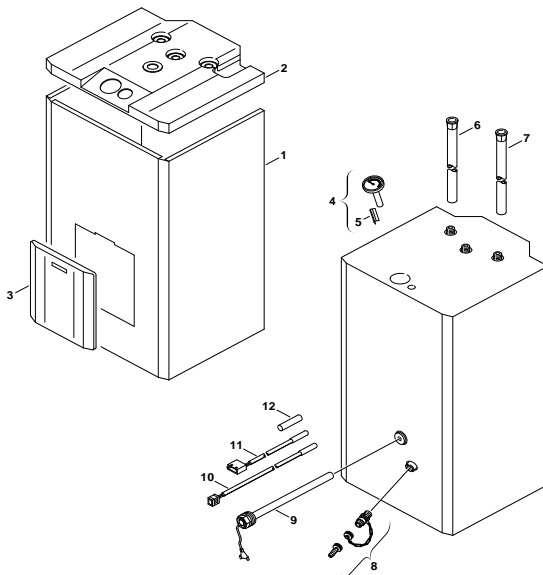

6720901199/G

Pos	Bestell-Nr.	Bezeichnung	Description	Dénomination	Descrizione	Benaming	Descripción	PG
1	8 715 401 293 0	Mantel weiß	Front shell white	Habillage blanc	Mantello bianco	Mantel wit	Carcasa blanco	53
2	8 715 503 362 0	Haube hellgrau	Hood light grey	Carpot gris clair	Coperchio grigio chiaro	Deksel lichtgrijs	Capota girar claro	42
3	8 715 503 397 0	Abdeckung hellgrau	Covering sheet light grey	Couvercle gris clair	Coperchio grigio chiaro	Afdichting lichtgrijs	Chapa de protección girar claro	41
4	8 717 208 050 0	Thermometer	Thermometer	Thermomètre	Termometro	Thermometer	Termómetro	31
5	8 714 606 024 0	Klemmfeder	Clamp spring	RESSORT POUR THERMOMETRE	Fermo	KLEEMVEER V/THERMOMETER ST/SO	Muelle fijación	20
6	8 710 735 187 0	Auslaufrohr Edelstahl 120mm	Outlet tube stainless steel 120mm	Tube de sortie acier spécial 120mm	Tubo di uscita in acciaio 120mm	Stalen uitloopbuisje 120mm	Tubo de salida del producto acero afinar	36
7	8 710 735 442 0	Einlaufrohr Edelstahl 850mm	Inlet tube stainless steel 850mm	Tube d'arrivée acier spécial 850mm	Tubo della presa acciaio raffinato 850mm	BUIS 850 MM INTERNE BOILERS (INOX)	Pipa del producto acero afinado 850mm	38
8	8 738 505 974 0	Ventil	Globe valve	Robinet	Valvola	AFLUITKRAAN	Válvula de globo	26
9	8 718 505 037 0	Anode	Anode	Anode	Anodo	Anode	Anodo	34
10	8 714 500 088 0	Temperaturfühler NTC1	Temperature sensor NTC1	Sonde de temperature CTN1	Sensore termometrico NTC1	Temperatuurvoeler NTC1	Sensor de temperatura NTC1	34
11	8 714 500 090 0	Temperaturfühler NTC2	Temperature sensor NTC2	Sonde de temperature CTN2	Sensore termometrico NTC2	Temperatuurvoeler NTC2	Sensor de temperatura NTC2	39
12	8 740 703 047 0	Silikonschlauch 250mm	Silicon hose 250mm	Tuyau de silicone 250mm	Tubo flessibile di silicone 250mm	SLANG ST 120/160 ES	Tubo flexible silicone 250mm	24

For:



**Ersatzteilliste**  
**Spare parts list**  
**Liste des pièces de rechange**  
**Lista parti di ricambio**  
**Onderdelenlijst**  
**Lista de repuestos**

# HRVS160 - 7719002082

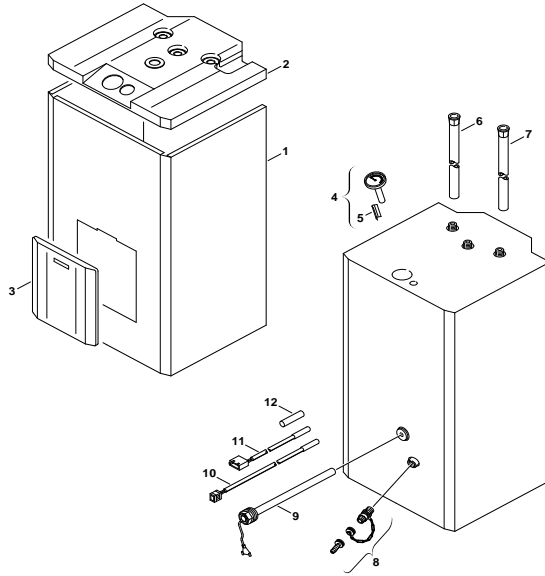

6720901199/G

Pos	Bestell-Nr.	Bezeichnung	Description	Dénomination	Descrizione	Benaming	Descripción	PG
1	8 715 401 296 0	Mantel weiß	Front shell white	Habillage blanc	Mantello bianco	Mantel wit	Carcasa blanco	54
2	8 715 503 363 0	Haube hellgrau	Hood light grey	Carpot gris clair	Coperchio grigio chiaro	DEKSEL ST 160 ES "STORAMAXX"	Capota girar claro	43
3	8 715 503 397 0	Abdeckung hellgrau	Covering sheet light grey	Couvercle gris clair	Coperchio grigio chiaro	Afdichting lichtgrijs	Chapa de protección girar claro	41
4	8 717 208 050 0	Thermometer	Thermometer	Thermomètre	Termometro	Thermometer	Termómetro	31
5	8 714 606 024 0	Klemmfeder	Clamp spring	RESSORT POUR THERMOMETRE	Fermo	KLEMVEER V/THERMOMETER ST/SO	Muelle fijación	20
6	8 710 735 187 0	Auslaufrohr Edelstahl 120mm	Outlet tube stainless steel 120mm	Tube de sortie acier spécial 120mm	Tubo di uscita in acciaio 120mm	Stalen uitloopbuisje 120mm	Tubo de salida del producto acero afinar	36
7	8 718 225 014 0	Rohr-Einlaufrohr 900mm	Pipe 900mm	Tube d'arrivée 900mm	Tubo della presa 900mm	Pijp 900mm	Pipa del producto 900mm	36
8	8 738 505 974 0	Ventil	Globe valve	Robinet	Valvola	AFSLUITKRAAN	Válvula de globo	26
9	8 718 505 037 0	Anode	Anode	Anode	Anodo	Anode	Anodo	34
10	8 714 500 088 0	Temperaturfühler NTC1	Temperature sensor NTC1	Sonde de temperature CTN1	Sensore termometrico NTC1	Temperatuurvoeler NTC1	Sensor de temperatura NTC1	34
11	8 714 500 090 0	Temperaturfühler NTC2	Temperature sensor NTC2	Sonde de temperature CTN2	Sensore termometrico NTC2	Temperatuurvoeler NTC2	Sensor de temperatura NTC2	39
12	8 740 703 047 0	Silikonschlauch 250mm	Silicon hose 250mm	Tuyau de silicone 250mm	Tubo flessibile di silicone 250mm	SLANG ST 120/160 ES	Tubo flexible silicone 250mm	24

For:

**Ersatzteilliste**  
**Spare parts list**  
**Liste des pièces de rechange**  
**Lista parti di ricambio**  
**Onderdelenlijst**  
**Lista de repuestos**

# P 500-80 S - 7719003036

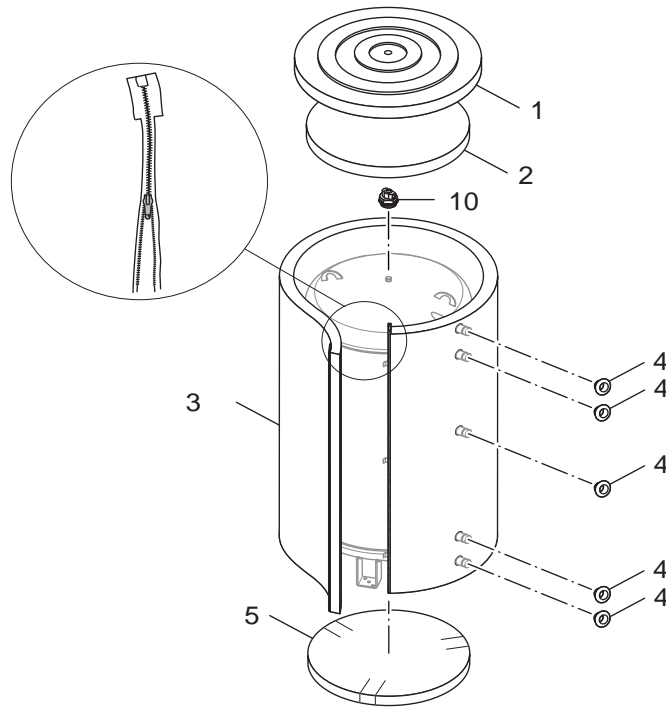

6720904819.ab.RS

Pos	Bestell-Nr.	Bezeichnung	Description	Dénomination	Descrizione	Benaming	Descripción	PG
1	8 718 221 678 0	Deckel 500-80 silber	cover 500-80 silver	Couvercle 500-80 argent	Coperchio 500-80 argentato	Deksel 500-80 zilver	tapa 500-80 plata	38
2	8 718 221 672 0	Isolierung oben 500-80	Insulation top 500-80	Isolation haut Ø665x80mm	Isolamento superiore Ø665x80 mm	Isolatie boven Ø665x80mm	Aislamiento superior Ø665x80mm	39
3	8 718 221 666 0	Mantel 500-80 silber	front shell 500-80 silver	Carénage 500-80 argent	Rivestimento 500-80 argentato	Mantel 500-80 zilver	revestimiento 500-80 plata	57
4	8 718 221 693 0	Rosette 1 1/4" silber	collar 1 1/4" silver	Rozet 1 1/4" argent	Rosetta 1 1/4" argentato	Rozet 1 1/4" zilver	rosetón 1 1/4" plata	16
5	8 718 541 812 0	Wärmeschutz 400/500 Boden	Insulation 400/500 bottom singl	Isolation 400/500 bas	Coibentazione 400/500 sotto	Isolatie 400/500 onder	Aislamiento 400/500 debajo	37
10	8 718 221 694 0	Entlüftungsventil 1/2"	deairing 1/2"	Vanne de purge 1/2	Valvola di sfiato 1/2	ONTLUCHTER 1/2" P500/750/100-120S	Válvula de purga de aire 1/2	14
	8 711 145 928 0	Logo Junkers	Trademark Junkers	Marquage Junkers	Targhetta Junkers	LOGO JUNKERS ZELFKLEVEND	Marca Junkers	16

For:

**Ersatzteilliste**  
**Spare parts list**  
**Liste des pièces de rechange**  
**Lista parti di ricambio**  
**Onderdelenlijst**  
**Lista de repuestos**

**P 500-120 S - 7719003039**

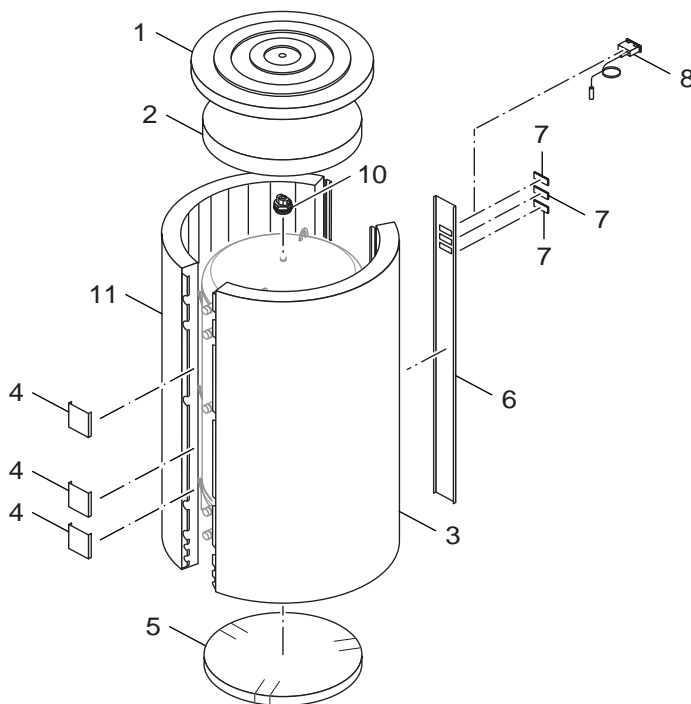

6720904820.ac.RS

Pos	Bestell-Nr.	Bezeichnung	Description	Dénomination	Descrizione	Benaming	Descripción	PG
1	<b>8 718 221 681 0</b>	Deckel 500-120 silber	cover 500-120 silver	Couvercle 500-120 argent	Coperchio 500-120 argentato	Deksel 500-120 zilver	tapa 500-120 plata	39
2	<b>8 718 221 675 0</b>	Isolierung oben 500-120	insulation top 500-120	Isolation haut 500-120	Isolamento superiore 500-120	Isolatie boven 500-120	Aislamiento superior 500-120	42
3	<b>8 718 541 957 0</b>	Wärmeschutz P500-120 re silber	Insulation P500-120 right silver single	Isolation P500-120 droite argent	Coibentazione P500-120 destra argentato	Isolatie P500-120 rechts zilver	Aislamiento P500-120 derecha plata	54
4	<b>8 718 221 684 0</b>	Schiene hinten silber 1 Stck	ledge rear silver (1piece)	Barre derrière argent (1x)	Binario dietro argentato (1x)	Strip achteraan zilver (1x)	rail detrás plata (1x)	22
5	<b>8 718 541 812 0</b>	Wärmeschutz 400/500 Boden	Insulation 400/500 bottom singl	Isolation 400/500 bas	Coibentazione 400/500 sotto	Isolatie 400/500 onder	Aislamiento 400/500 debajo	37
6	<b>8 718 221 685 0</b>	Schiene vorn 500 silber	ledge front 500 silver	Barre devant argent	Binario davanti argentato	Strip vooraan 500 zilver	rail delante 500 plata	41
7	<b>8 718 221 688 0</b>	Abdeckung 28x61x6 silber	Cover plate 28x61x6 silver	Recouvrement 28x61x6 argent	Copertura 28x61x6 argento	Afdekking 28x61x6 zilver	Recubrimiento 28x61x6 plata	15
8	<b>7 747 201 004</b>	Digital-Thermometer DTA	Digital-Thermometer DTA mit Kapillare 3	Thermomètre numérique DTA	SONDA BOLLITORE DIGITALE DTA	THERMOMETER DIGITAAL P500/750/100-120S	Termometro Digital SU750	
10	<b>8 718 221 694 0</b>	Entlüftungsventil 1/2"	deairing 1/2"	Vanne de purge 1/2	Valvola di sfiato 1/2	ONTLUCHTER 1/2" P500/750/100-120S	Válvula de purga de aire 1/2	14
11	<b>8 718 541 956 0</b>	Wärmeschutz P500-120 li silber	Insulation P500-120 left silver	Isolation P500-120 gauche argent	Coibentazione P500-120 sinis argentato	Isolatie P500-120 links zilver	Aislamiento P500-120 izquierda plata	54
	<b>8 711 145 928 0</b>	Logo Junkers	Trademark Junkers	Marquage Junkers	Targhetta Junkers	LOGO JUNKERS ZELFKLEVEND	Marca Junkers	16

For:



Ersatzteilliste  
 Spare parts list  
 Liste des pièces de rechange  
 Lista parti di ricambio  
 Onderdelenlijst  
 Lista de repuestos

# P 750-120 S - 7719003040

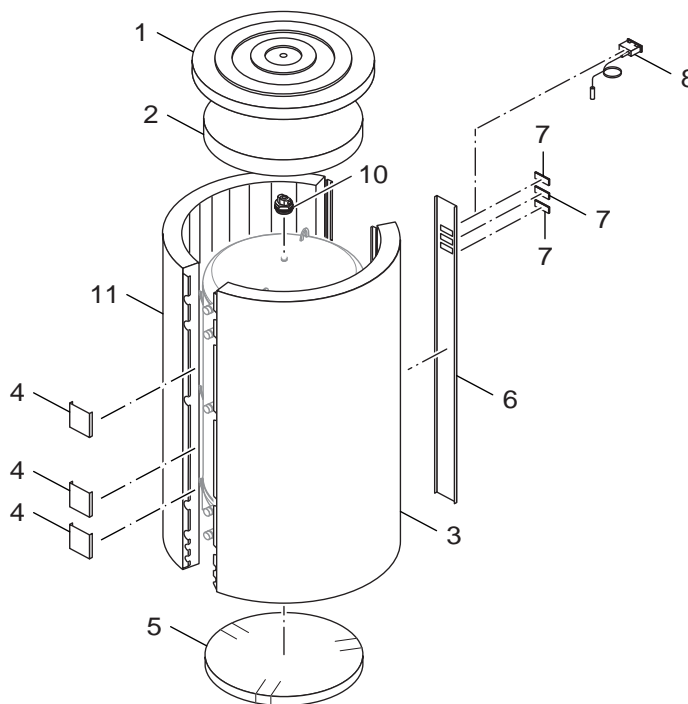

6720904820.ac.RS

Pos	Bestell-Nr.	Bezeichnung	Description	Dénomination	Descrizione	Benaming	Descripción	PG
1	8 718 221 682 0	Deckel 750-120 silber	cover 750-120 silver	Couvercle 750-120 argent	Coperchio 750-120 argentato	Deksel 750-120 zilver	tapa 750-120 plata	41
2	8 718 541 853 0	Wärmeschutz 750-120 Deckel	Insulation 750-120 top single pack	Isolation 750-120 Couvercle	Coibentazione 750-120 Coperchio	Isolatie 750-120 Deksel	Aislamiento 750-1200 Tapa	43
3	8 718 541 959 0	Wärmeschutz P750-120 re silber	Insulation P750-120 right silver single	Isolation P750-120 droite argent	Coibentazione P750-120 destra argentato	Isolatie P750-120 rechts zilver	Aislamiento P750-120 derecha plata	55
4	8 718 221 684 0	Schiene hinten silber 1 Stck	ledge rear silver (1piece)	Barre derrière argent (1x)	Binario dietro argentato (1x)	Strip achteraan zilver (1x)	rail detrás plata (1x)	22
5	8 718 541 821 0	Wärmeschutz 750/2 Boden	Insulation 750/2 bottom single pac	Isolation 750/2 bas	Coibentazione 750/2 sotto	Isolatie 750/2 onder	Aislamiento 750/2 debajo	39
6	8 718 221 686 0	Schiene vorn 750 silber	ledge front 750 silver	Barre devant 750 argent	Binario davanti 750 argentato	Strip vooraan 750 zilver	rail delante 750 plata	41
7	8 718 221 688 0	Abdeckung 28x61x6 silber	Cover plate 28x61x6 silver	Recouvrement 28x61x6 argent	Copertura 28x61x6 argento	Afdekking 28x61x6 zilver	Recubrimiento 28x61x6 plata	15
8	7 747 201 004	Digital-Thermometer DTA	Digital-Thermometer DTA mit Kapillare 3	Thermomètre numérique DTA	SONDA BOLLITORE DIGITALE DTA	THERMOMETER DIGITAAL P500/750/100-120S	Termometro Digital SU750	
10	8 718 221 694 0	Entlüftungsventil 1/2"	deairing 1/2"	Vanne de purge 1/2	Valvola di sfiato 1/2	ONTLUCHTER 1/2" P500/750/100-120S	Válvula de purga de aire 1/2	14
11	8 718 541 958 0	Wärmeschutz P750-120 li silber	Insulation P750-120 left silver	Isolation P750-120 gauche argent	Coibentazione P750-120 sinis argentato	Isolatie P750-120 links zilver	Aislamiento P750-120 izquierda plata	55
	8 711 145 928 0	Logo Junkers	Trademark Junkers	Marquage Junkers	Targhetta Junkers	LOGO JUNKERS ZELFKLEVEND	Marca Junkers	16

For:



Ersatzteilliste  
Spare parts list  
Liste des pièces de rechange  
Lista parti di ricambio  
Onderdelenlijst  
Lista de repuestos

# P 1000-120 S - 7719003041

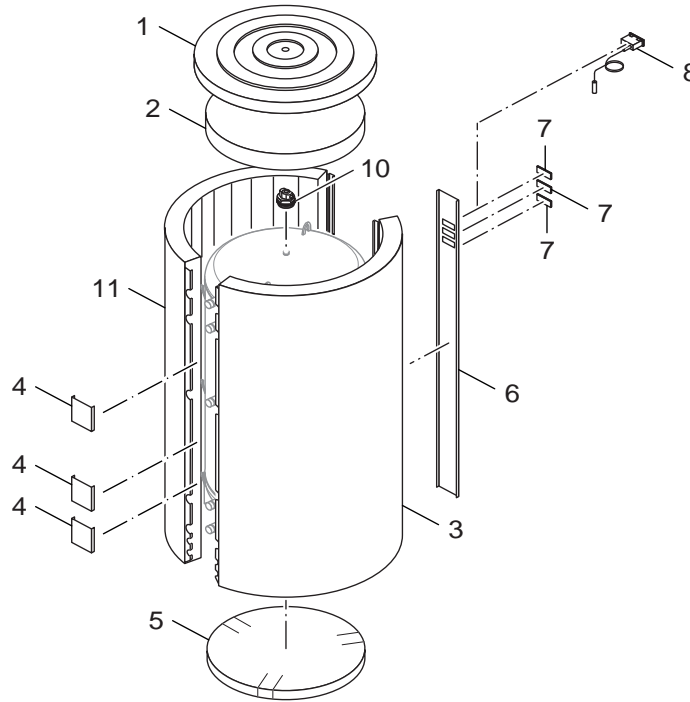

6720904820.ac.RS

Pos	Bestell-Nr.	Bezeichnung	Description	Dénomination	Descrizione	Benaming	Descripción	PG
1	8 718 224 374 0	Abdeckung Deckel P1000-120 silber	cover P1000-120 top silver	Couvercle P1000-120 haut argent	Copertura tetto P1000-120 sopra argentat	afdekkap, afdekking P1000-120 Boven zilver	recubrimiento P1000-120 arriba plata	42
2	8 718 541 859 0	Wärmeschutz 1000-120 Deckel	Insulation 1000-120 top single pack	Isolation 1000-120 Couvercle	Coibentazione 1000-120 Coperchio	Isolatie 1000-120 Deksel	Aislamiento 1000-120 Tapa	45
3	8 718 541 961 0	Wärmeschutz P1000-120 re silber	Insulation P1000-120 right silver single	Isolation P1000-120 droite argent	Coibentazione P1000-120 destra argentato	Isolatie P1000-120 rechts zilver	Aislamiento P1000-120 derecha plata	56
4	8 718 221 684 0	Schiene hinten silber 1 Stck	ledge rear silver (1piece)	Barre derrière argent (1x)	Binario dietro argentato (1x)	Strip achteraan zilver (1x)	rail detrás plata (1x)	22
5	8 718 541 829 0	Wärmeschutz 1000/2 Boden	Insulation 1000/2 bottom	Isolation 1000/2 bas	Coibentazione 1000/2 sotto	Isolatie 1000/2 onder	Aislamiento 1000/2 debajo	40
6	8 718 221 687 0	Schiene vorn 1000 silber	ledge front 1000 silver	Barre devant 1000 argent	Binario davanti 1000 argentato	Strip vooraan 1000 zilver	rail delante 1000 plata	41
7	8 718 221 688 0	Abdeckung 28x61x6 silber	Cover plate 28x61x6 silver	Recouvrement 28x61x6 argent	Copertura 28x61x6 argento	Afdekking 28x61x6 zilver	Recubrimiento 28x61x6 plata	15
8	7 747 201 004	Digital-Thermometer DTA	Digital-Thermometer DTA mit Kapillare 3	Thermomètre numérique DTA	SONDA BOLLITORE DIGITALE DTA	THERMOMETER DIGITAAL P500/750/100-120S	Termometro Digital SU750	
10	8 718 221 694 0	Entlüftungsventil 1/2"	deairing 1/2"	Vanne de purge 1/2	Valvola di sfiato 1/2	ONTLUCHTER 1/2" P500/750/100-120S	Válvula de purga de aire 1/2	14
11	8 718 541 960 0	Wärmeschutz P1000-120 li silber	Insulation P1000-120 left silver	Isolation P1000-120 gauche argent	Coibentazione P1000-1 sinistra argentato	Isolatie P1000-120 links zilver	Aislamiento P1000-120 izquierda plata	56
	8 711 145 928 0	Logo Junkers	Trademark Junkers	Marquage Junkers	Targhetta Junkers	LOGO JUNKERS ZELFKLEVEND	Marca Junkers	16

For:

Ersatzteilliste  
Spare parts list  
Liste des pièces de rechange  
Lista parti di ricambio  
Onderdelenlijst  
Lista de repuestos

# SE 120 - 7719002319

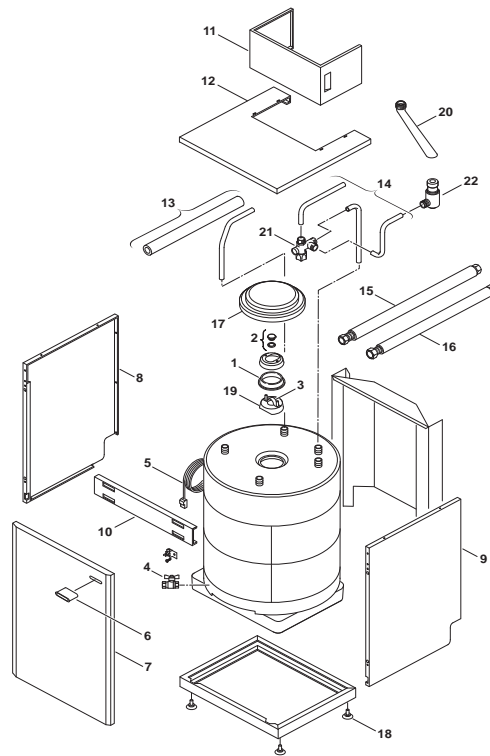

6720904056.AC/G

Pos	Bestell-Nr.	Bezeichnung	Description	Dénomination	Descrizione	Benaming	Descripción	PG
1	8 711 004 340 0	Dichtung	sealing	Joint de trappe de visite	Guarnizione	Pakkung	Junta	18
2	8 710 506 240 0	Stopfen	Grommet	Bouchon	Coperchietto	Doorvoertule	Tapon	23
3	8 714 500 113 0	Temperaturfühler	Temperature sensor	Sonde de temperature	Sensore termometrico	Temperatuurvoeler	Sensor de temperatura	26
4	8 717 405 235 0	Entleerhahn	Drain valve	Robinet de vidange	Rubinetto di scarico	Aftapkraan	grifo de vaciado	30
5	8 714 407 010 0	Kabel	Cable	Faisceau	Cablaggio	Kabel	Cable	28
6	8 717 208 104 0	Thermometer	Thermometer	Thermomètre	Termometro	Thermometer	Termómetro	30
7	8 715 401 419 0	Vorderwand	Cover	Façade jaquette SE120 avec clips et logo	Coperchio	Voordeksel	Coperchio	40
8	8 718 007 439 0	Seitenwand links	Side panel left	Côté gauche jaquette avec clips + vis SA	Pannelo laterale sinistra	Zijpaneel links	Pared lateral a la izquierda	38
9	8 718 007 438 0	Seitenwand rechts	Side panel right	Côté droit jaquette avec clips + vis SAV	Pannelo laterale a destra	Zijpaneel rechts	Pared lateral a la derecha	38
10	8 718 007 440 0	Traverse	Connection plate	Traverse	Traversa	Vangschaal	Placa de unión	26
11	8 715 503 479 0	Blende	Shield	Cache	Mascherina	Paneel	Chapa cuadro	35
12	8 718 005 757 0	Deckel	Cover	Couvercle	Coperchio	Deksel	Coperchio	40
13	8 710 735 144 0	Verbindungsrohr	Connecting pipe	Tube de raccordement	Raccordo	Verbindingspijp	Tubo agua	38
14	8 710 735 121 0	Rohrsatz	Set of Pipes	Jeu de tubes	Raccordo	Pijp set	Conjunto de tubo	40
15	8 710 703 215 0	Vorlaufrohr	Flow pipe	Tube départ chauffage	Raccordo	Aanvoerleiding	Tubo de salida	33
16	8 710 703 206 0	Rücklaufrohr	Return pipe	Tube retour chauffage	Tubazione di ritorno	Retourleiding	Tubo di ritorno	33
17	8 712 303 550 0	Isolierung	Insulation	Isolation	Isolamento	Isolatie	Aislamiento	28
18	8 711 304 779 0	Stellfuß	Foot	Pied	Vite	Voet	Pie	18
19	8 715 506 681 0	Handlochdeckel	Hand hole cover	Trappe de visite	Coperchio d'ispezione	Handgatdeksel	Tapa de la boca de hombre	46
20	8 710 702 108 0	Ablaufrohr	DRAINAGE PIPE	drainage pipe	drainage pipe	drainage pipe	drainage pipe	14
21	8 717 405 158 0	Verteiler	Distributor	Raccord	Distributore	Kortsluitleiding	Boquilla de purga	39
22	8 717 405 160 0	Sicherheitsventil	Safety relief valve	Soupape de sécurité	Valvola sicurezza	Veiligheidsklep	Válvula de sobrepresión	34
	7 719 002 361	Nr.986 Fremdstromanode	Nr.986 anode	Nr.986 sonde	Nr.986 Anodo	Nr.986 Anode	Nr.986 Anodo	

For:



**Ersatzteilliste**  
**Spare parts list**  
**Liste des pièces de rechange**  
**Lista parti di ricambio**  
**Onderdelenlijst**  
**Lista de repuestos**

# SE 150-1 - 7719003272

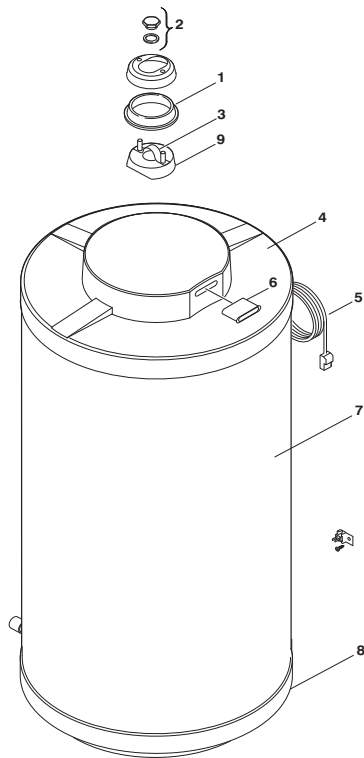

Pos	Bestell-Nr.	Bezeichnung	Description	Dénomination	Descrizione	Benaming	Descripción	PG
1	8 711 004 340 0	Dichtung	sealing	Joint de trappe de visite	Guarnizione	Pakkung	Junta	18
3	8 714 500 113 0	Temperaturfühler	Temperature sensor	Sonde de temperature	Sensore termometrico	Temperatuurvoeler	Sensor de temperatura	26
4	8 718 005 762 0	Deckel hellgrau	Cover light grey	Couvercle gris clair	Coperchio grigio chiaro	Deksel lichtgrijs	Tapa girar claro	44
5	8 714 407 010 0	Kabel	Cable	Faisceau	Cablaggio	Kabel	Cable	28
6	8 717 208 104 0	Thermometer	Thermometer	Thermomètre	Termometro	Thermometer	Termómetro	30
7	8 715 401 427 0	Mantel weiß	Front shell white	Habillage blanc	Mantello bianco	Mantel wit	Carcasa blanco	46
8	8 718 005 760 0	Boden	Floor panel	Socle	Basamento	Bodemplaat	Base de radiator	44
9	8 716 826 382 0	Handlochdeckel	INSPECTION WINDOW	TRAPPE DE VISITE SAV SANS ANODE	Coperchio d'ispezione	Handgatdekseel	Trampilla deposito acumulador sin anodo	43

For:



Ersatzteilliste  
 Spare parts list  
 Liste des pièces de rechange  
 Lista parti di ricambio  
 Onderdelenlijst  
 Lista de repuestos

# SE 300-1 - 7719003274

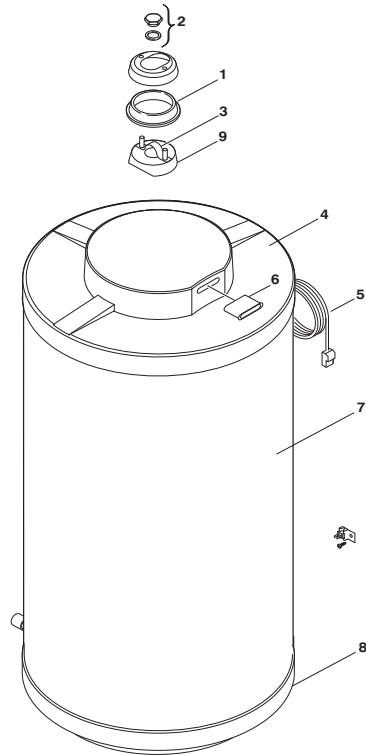

Pos	Bestell-Nr.	Bezeichnung	Description	Dénomination	Descrizione	Benaming	Descripción	PG
1	8 711 004 340 0	Dichtung	sealing	Joint de trappe de visite	Guarnizione	Pakkung	Junta	18
3	8 714 500 113 0	Temperaturfühler	Temperature sensor	Sonde de temperature	Sensore termometrico	Temperatuurvoeler	Sensor de temperatura	26
4	8 718 005 762 0	Deckel hellgrau	Cover light grey	Couvercle gris clair	Coperchio grigio chiaro	Deksel lichtgrijs	Tapa girar claro	44
5	8 714 407 010 0	Kabel	Cable	Faisceau	Cablaggio	Kabel	Cable	28
6	8 717 208 104 0	Thermometer	Thermometer	Thermomètre	Termometro	Thermometer	Termómetro	30
7	8 715 401 436 0	Mantel weiß	Front shell white	Habillage blanc	Mantello bianco	Mantel wit	Carcasa blanco	48
8	8 718 005 760 0	Boden	Floor panel	Socle	Basamento	Bodemplaat	Base de radiator	44
9	8 716 826 382 0	Handlochdeckel	INSPECTION WINDOW	TRAPPE DE VISITE SAV SANS ANODE	Coperchio d'ispezione	Handgatdeksel	Trampilla deposito acumulador sin anodo	43

For:

Ersatzteilliste  
Spare parts list  
Liste des pièces de rechange  
Lista parti di ricambio  
Onderdelenlijst  
Lista de repuestos

**SE120-1 - 7719003271**

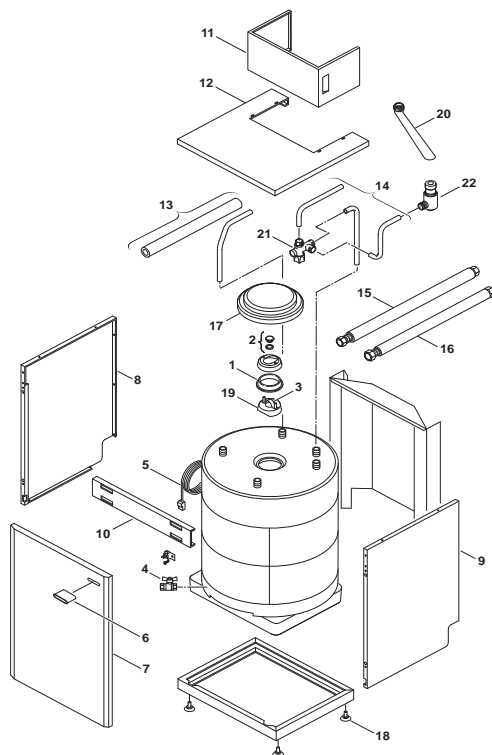

6720904056.AC/G

Pos	Bestell-Nr.	Bezeichnung	Description	Dénomination	Descrizione	Benaming	Descripción	PG
1	8 711 004 340 0	Dichtung	sealing	Joint de trappe de visite	Guarnizione	Pakkung	Junta	18
3	8 714 500 113 0	Temperaturfühler	Temperature sensor	Sonde de temperature	Sensore termometrico	Temperatuurvoeler	Sensor de temperatura	26
4	8 717 405 235 0	Entleerhahn	Drain valve	Robinet de vidange	Rubinetto di scarico	Aftapkraan	grifo de vaciado	30
5	8 714 407 010 0	Kabel	Cable	Faisceau	Cablaggio	Kabel	Cable	28
6	8 717 208 104 0	Thermometer	Thermometer	Thermomètre	Termometro	Thermometer	Termómetro	30
7	8 715 401 419 0	Vorderwand	Cover	Façade jaquette SE120 avec clips et logo	Coperchio	Voordeksel	Coperchio	40
8	8 718 007 439 0	Seitenwand links	Side panel left	Côté gauche jaquette avec clips + vis SA	Pannelo laterale sinistra	Zijpaneel links	Pared lateral a la izquierda	38
9	8 718 007 438 0	Seitenwand rechts	Side panel right	Côté droit jaquette avec clips + vis SAV	Pannelo laterale a destra	Zijpaneel rechts	Pared lateral a la derecha	38
10	8 718 007 440 0	Traverse	Connection plate	Traverse	Traversa	Vangschaal	Placa de unión	26
11	8 715 503 479 0	Blende	Shield	Cache	Mascherina	Paneel	Chapa cuadro	35
12	8 718 005 757 0	Deckel	Cover	Couvercle	Coperchio	Deksel	Coperchio	40
13	8 710 735 144 0	Verbindungsrohr	Connecting pipe	Tube de raccordement	Raccordo	Verbindingspijp	Tubo agua	38
14	8 710 735 121 0	Rohrsatz	Set of Pipes	Jeu de tubes	Raccordo	Pijp set	Conjunto de tubo	40
15	8 710 703 215 0	Vorlaufrohr	Flow pipe	Tube départ chauffage	Raccordo	Aanvoerleiding	Tubo de salida	33
16	8 710 703 206 0	Rücklaufrohr	Return pipe	Tube retour chauffage	Tubazione di ritorno	Retourleiding	Tubo di ritorno	33
17	8 712 303 550 0	Isolierung	Insulation	Isolation	Isolamento	Isolatie	Aislamiento	28
18	8 711 304 779 0	Stellfuß	Foot	Pied	Vite	Voet	Pie	18
19	8 716 826 382 0	Handlochdeckel	INSPECTION WINDOW	TRAPPE DE VISITE SAV SANS ANODE	Coperchio d'ispezione	Handgatdeksel	Trampilla deposito acumulador sin anodo	43
20	8 710 702 108 0	Ablaufrohr	DRAINAGE PIPE	drainage pipe	drainage pipe	drainage pipe	drainage pipe	14
21	8 717 405 158 0	Verteiler	Distributor	Raccord	Distributore	Kortsluitleiding	Boquilla de purga	39
22	8 717 405 160 0	Sicherheitsventil	Safety relief valve	Soupape de sécurité	Valvola sicurezza	Veiligheidsklep	Válvula de sobrepresión	34

For:

Ersatzteilliste  
 Spare parts list  
 Liste des pièces de rechange  
 Lista parti di ricambio  
 Onderdelenlijst  
 Lista de repuestos

# SE150C1 - 7719002320

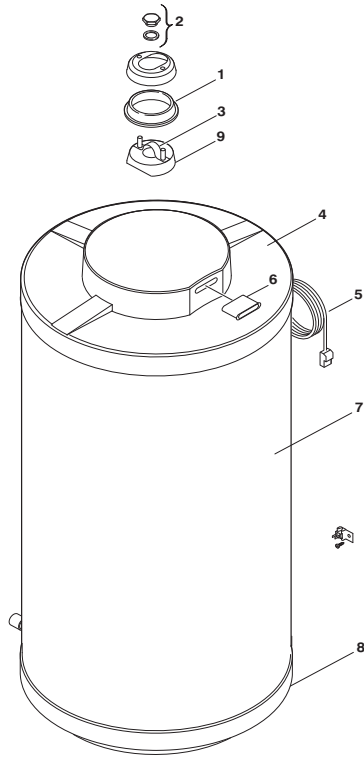

Pos	Bestell-Nr.	Bezeichnung	Description	Dénomination	Descrizione	Benaming	Descripción	PG
1	8 711 004 340 0	Dichtung	sealing	Joint de trappe de visite	Guarnizione	Pakkung	Junta	18
2	8 710 506 240 0	Stopfen	Grommet	Bouchon	Coperchietto	Doorvoertule	Tapon	23
3	8 714 500 113 0	Temperaturfühler	Temperature sensor	Sonde de temperature	Sensore termometrico	Temperatuurvoeler	Sensor de temperatura	26
4	8 718 005 762 0	Deckel hellgrau	Cover light grey	Couvercle gris clair	Coperchio grigio chiaro	Deksel lichtgrijs	Tapa girar claro	44
5	8 714 407 010 0	Kabel	Cable	Faisceau	Cablaggio	Kabel	Cable	28
6	8 717 208 104 0	Thermometer	Thermometer	Thermomètre	Termometro	Thermometer	Termómetro	30
7	8 715 401 427 0	Mantel weiß	Front shell white	Habillage blanc	Mantello bianco	Mantel wit	Carcasa blanco	46
8	8 718 005 760 0	Boden	Floor panel	Socle	Basamento	Bodemplaat	Base de radiator	44
9	8 715 506 681 0	Handlochdeckel	Hand hole cover	Trappe de visite	Coperchio d'ispezione	Handgatdeksel	Tapa de la boca de hombre	46
	7 719 002 361	Nr.986 Fremdstromanode	Nr.986 anode	Nr.986 sonde	Nr.986 Anodo	Nr.986 Anode	Nr.986 Anodo	

For:

Ersatzteilliste  
 Spare parts list  
 Liste des pièces de rechange  
 Lista parti di ricambio  
 Onderdelenlijst  
 Lista de repuestos

# SE150C2 - 7719002323

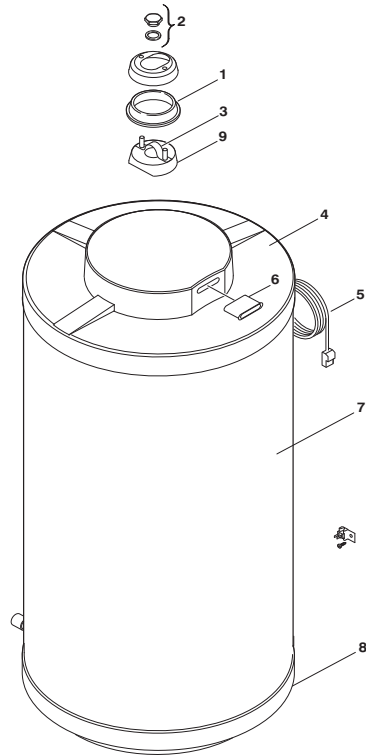

Pos	Bestell-Nr.	Bezeichnung	Description	Dénomination	Descrizione	Benaming	Descripción	PG
1	8 711 004 340 0	Dichtung	sealing	Joint de trappe de visite	Guarnizione	Pakkung	Junta	18
2	8 710 506 240 0	Stopfen	Grommet	Bouchon	Coperchietto	Doorvoertule	Tapon	23
3	8 714 500 113 0	Temperaturfühler	Temperature sensor	Sonde de temperature	Sensore termometrico	Temperatuurvoeler	Sensor de temperatura	26
4	8 718 005 770 0	Deckel silbergrau	Cover silver grey	Couvercle argent gris	Coperchio argentato grigio	Deksel zilver grijs	Tapa plata girar	44
5	8 714 407 010 0	Kabel	Cable	Faisceau	Cablaggio	Kabel	Cable	28
6	8 717 208 104 0	Thermometer	Thermometer	Thermomètre	Termometro	Thermometer	Termómetro	30
7	8 715 401 430 0	Mantel silbergrau	Front shell silver grey	Habillage argent gris	Mantello argentato grigio	Mantel zilver grijs	Carcasa plata girar	46
8	8 718 005 771 0	Boden	Floor panel	Socle	Basamento	Bodemplaat	Base de radiator	44
9	8 715 506 681 0	Handlochdeckel	Hand hole cover	Trappe de visite	Coperchio d'ispezione	Handgatdeksel	Tapa de la boca de hombre	46
	7 719 002 361	Nr.986 Fremdstromanode	Nr.986 anode	Nr.986 sonde	Nr.986 Anodo	Nr.986 Anode	Nr.986 Anodo	

For:

**Ersatzteilliste**

Spare parts list

Liste des pièces de rechange

Lista parti di ricambio

Onderdelenlijst

Lista de repuestos

# SE200C1 - 7719002321

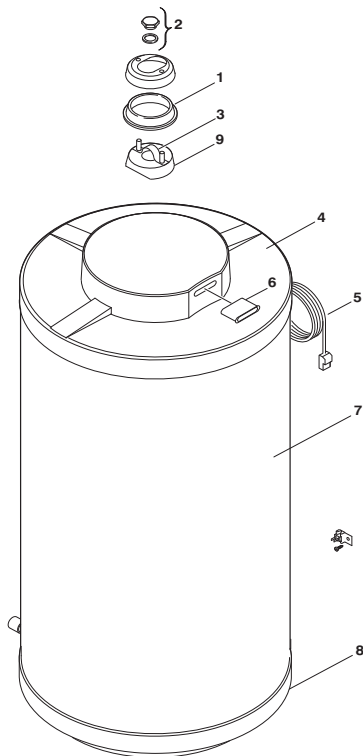

Pos	Bestell-Nr.	Bezeichnung	Description	Dénomination	Descrizione	Benaming	Descripción	PG
1	<b>8 711 004 340 0</b>	Dichtung	sealing	Joint de trappe de visite	Guarnizione	Pakkung	Junta	18
2	<b>8 710 506 240 0</b>	Stopfen	Grommet	Bouchon	Coperchietto	Doorvoertule	Tapon	23
3	<b>8 714 500 113 0</b>	Temperaturfühler	Temperature sensor	Sonde de temperature	Sensore termometrico	Temperatuurvoeler	Sensor de temperatura	26
4	<b>8 718 005 762 0</b>	Deckel hellgrau	Cover light grey	Couvercle gris clair	Coperchio grigio chiaro	Deksel lichtgrijs	Tapa girar claro	44
5	<b>8 714 407 010 0</b>	Kabel	Cable	Faisceau	Cablaggio	Kabel	Cable	28
6	<b>8 717 208 104 0</b>	Thermometer	Thermometer	Thermomètre	Termometro	Thermometer	Termómetro	30
7	<b>8 715 401 434 0</b>	Mantel weiß	Front shell white	Habillage blanc	Mantello bianco	Mantel wit	C carcasa blanco	46
8	<b>8 718 005 760 0</b>	Boden	Floor panel	Socle	Basamento	Bodemplaat	Base de radiator	44
9	<b>8 715 506 681 0</b>	Handlochdeckel	Hand hole cover	Trappe de visite	Coperchio d'ispezione	Handgatdeksel	Tapa de la boca de hombre	46
	<b>7 719 002 361</b>	Nr.986 Fremdstromanode	Nr.986 anode	Nr.986 sonde	Nr.986 Anodo	Nr.986 Anode	Nr.986 Anodo	

For:

**Ersatzteilliste**  
**Spare parts list**  
**Liste des pièces de rechange**  
**Lista parti di ricambio**  
**Onderdelenlijst**  
**Lista de repuestos**

# SE200C2 - 7719002324

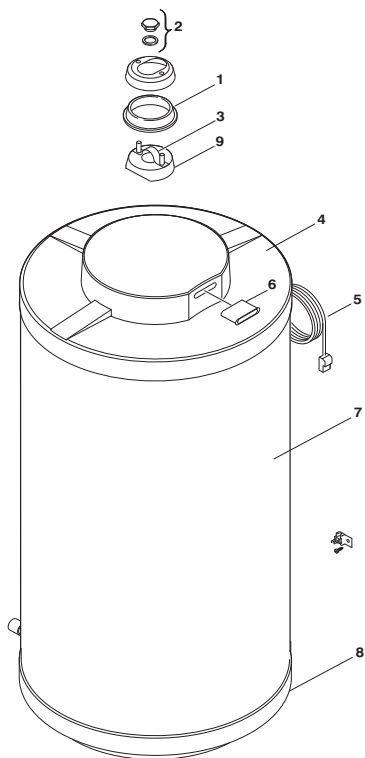

Pos	Bestell-Nr.	Bezeichnung	Description	Dénomination	Descrizione	Benaming	Descripción	PG
1	8 711 004 340 0	Dichtung	sealing	Joint de trappe de visite	Guarnizione	Pakkung	Junta	18
2	8 710 506 240 0	Stopfen	Grommet	Bouchon	Coperchietto	Doorvoertule	Tapon	23
3	8 714 500 113 0	Temperaturfühler	Temperature sensor	Sonde de temperature	Sensore termometrico	Temperatuurvoeler	Sensor de temperatura	26
4	8 718 005 770 0	Deckel silbergrau	Cover silver grey	Couvercle argent gris	Coperchio argentato grigio	Deksel zilver grijs	Tapa plata girar	44
5	8 714 407 010 0	Kabel	Cable	Faisceau	Cablaggio	Kabel	Cable	28
6	8 717 208 104 0	Thermometer	Thermometer	Thermomètre	Termometro	Thermometer	Termómetro	30
7	8 715 401 433 0	Mantel SE200C2	Front shell SE200C2	Habillage SE200C2	Mantello SE200C2	Mantel SE200C2	Carcasa SE200C2	46
8	8 718 005 771 0	Boden	Floor panel	Socle	Basamento	Bodemplaat	Base de radiator	44
9	8 715 506 681 0	Handlochdeckel	Hand hole cover	Trappe de visite	Coperchio d'ispezione	Handgatdeksel	Tapa de la boca de hombre	46
	7 719 002 361	Nr.986 Fremdstromanode	Nr.986 anode	Nr.986 sonde	Nr.986 Anodo	Nr.986 Anode	Nr.986 Anodo	

For: \_\_\_\_\_



Ersatzteilliste  
Spare parts list  
Liste des pièces de rechange  
Lista parti di ricambio  
Onderdelenlijst  
Lista de repuestos

# SE300C1 - 7719002322

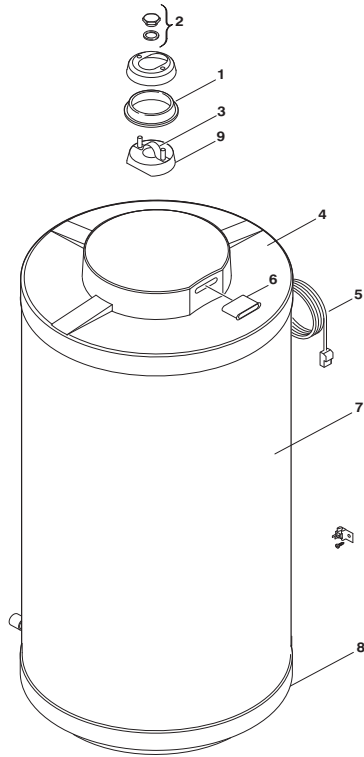

Pos	Bestell-Nr.	Bezeichnung	Description	Dénomination	Descrizione	Benaming	Descripción	PG
1	8 711 004 340 0	Dichtung	sealing	Joint de trappe de visite	Guarnizione	Pakkung	Junta	18
2	8 710 506 240 0	Stopfen	Grommet	Bouchon	Coperchietto	Doorvoertule	Tapon	23
3	8 714 500 113 0	Temperaturfühler	Temperature sensor	Sonde de temperature	Sensore termometrico	Temperatuurvoeler	Sensor de temperatura	26
4	8 718 005 762 0	Deckel hellgrau	Cover light grey	Couvercle gris clair	Coperchio grigio chiaro	Deksel lichtgrijs	Tapa girar claro	44
5	8 714 407 010 0	Kabel	Cable	Faisceau	Cablaggio	Kabel	Cable	28
6	8 717 208 104 0	Thermometer	Thermometer	Thermomètre	Termometro	Thermometer	Termómetro	30
7	8 715 401 436 0	Mantel weiß	Front shell white	Habillage blanc	Mantello bianco	Mantel wit	Carcasa blanco	48
8	8 718 005 760 0	Boden	Floor panel	Socle	Basamento	Bodemplaat	Base de radiator	44
9	8 715 506 681 0	Handlochdeckel	Hand hole cover	Trappe de visite	Coperchio d'ispezione	Handgatdeksel	Tapa de la boca de hombre	46
	7 719 002 364	Fremdstromanode Nr.987	external current anode Nr.987 silver	Anode Nr.987	Anodo Nr.987	Anode Nr.987	anodo Nr.987	

For:

Ersatzteilliste  
Spare parts list  
Liste des pièces de rechange  
Lista parti di ricambio  
Onderdelenlijst  
Lista de repuestos

# SE300C2 - 7719002325

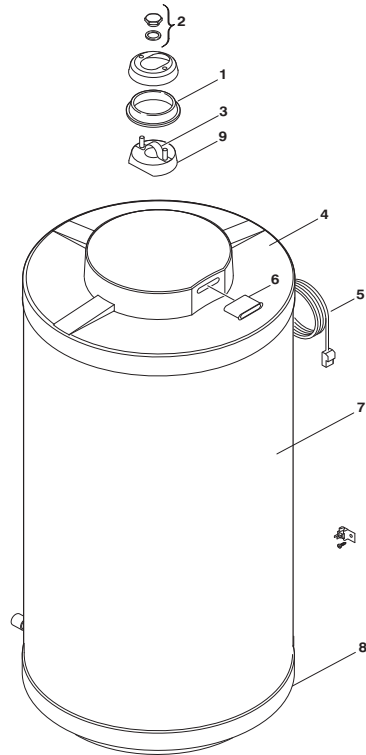

Pos	Bestell-Nr.	Bezeichnung	Description	Dénomination	Descrizione	Benaming	Descripción	PG
1	8 711 004 340 0	Dichtung	sealing	Joint de trappe de visite	Guarnizione	Pakkung	Junta	18
2	8 710 506 240 0	Stopfen	Grommet	Bouchon	Coperchietto	Doorvoertule	Tapon	23
3	8 714 500 113 0	Temperaturfühler	Temperature sensor	Sonde de temperature	Sensore termometrico	Temperatuurvoeler	Sensor de temperatura	26
4	8 718 005 770 0	Deckel silbergrau	Cover silver grey	Couvercle argent gris	Coperchio argentato grigio	Deksel zilver grijs	Tapa plata girar	44
5	8 714 407 010 0	Kabel	Cable	Faisceau	Cablaggio	Kabel	Cable	28
6	8 717 208 104 0	Thermometer	Thermometer	Thermomètre	Termometro	Thermometer	Termómetro	30
7	8 715 401 435 0	Mantel silbergrau	Front shell silver grey	Habillage argent gris	Mantello argentato grigio	Mantel zilver grijs	Carcasa plata girar	48
8	8 718 005 771 0	Boden	Floor panel	Socle	Basamento	Bodemplaat	Base de radiator	44
9	8 715 506 681 0	Handlochdeckel	Hand hole cover	Trappe de visite	Coperchio d'ispezione	Handgatdeksel	Tapa de la boca de hombre	46
	7 719 002 364	Fremdstromanode Nr.987	external current anode Nr.987 silver	Anode Nr.987	Anodo Nr.987	Anode Nr.987	anodo Nr.987	

For:

Ersatzteilliste

Spare parts list

Liste des pièces de rechange

Lista parti di ricambio

Onderdelenlijst

Lista de repuestos

# SK 120-4 ZB - 7719001931

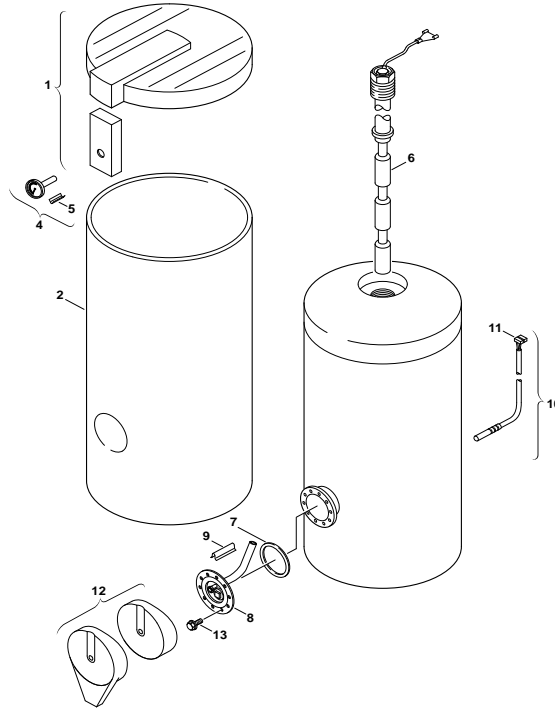

6720901190.AB/G

Pos	Bestell-Nr.	Bezeichnung	Description	Dénomination	Descrizione	Benaming	Descripción	PG
1	8 715 503 188 0	Haube hellgrau	Hood light grey	Carpot gris clair	Coperchio grigio chiaro	DEKSEL SK 160-4ZB (VOOR BOILER 771900193)	Capota girar claro	42
2	8 715 401 348 0	Mantel weiß	Shell white	Habillage blanc	Mantello bianco	Mantel wit	Carcasa blanco	48
4	8 717 208 050 0	Thermometer	Thermometer	Thermomètre	Termometro	Thermometer	Termómetro	31
5	8 714 606 024 0	Klemmfeder	Clamp spring	RESSORT POUR THERMOMETRE	Fermo	KLEMVEER V/THERMOMETER ST/ISO	Muelle fijación	20
6	8 709 918 638 0	Anode 1"	Anode 1"	Anode 1"	Anodo 1"	ANODE SK 120/140/160-4ZB	Anodo 1"	37
7	8 710 103 096 0	Dichtungs-Set 100x109D - 115/138Dx3 (1x)	Set of seals 100x109D - 115/138Dx3 (1x)	Jeu de joints 100x109D - 115/138Dx3 (1x)	Set guarnizioni 100x109D - 115/138Dx3	DICHTING FLENS SK...ZZB-3ZB (VANAF 07/0)	conjunto de juntas 100x109D - 115/138Dx3	23
8	8 715 503 170 0	Flansch mit Tauchrohr kpl.	Connecting flange	Bride de raccordement	Flangia	FLENS + DICHTING SK - 3ZB	Conjunto brida y junta SK500	40
9	8 714 606 021 0	Klemmfeder	Clamp spring	Ressort	Fermo	KLEMVEER NTC SK 120/140/160-4ZB	Muelle de tecla	25
10	8 714 500 034 0	Sensor WW-NTC mit Aderendhülse 6mm	Temperature sensor 6mm	SONDE DE TEMPERATURE 6mm	Sensore termometrico 6mm	Temperatuurvoeler 6mm	Sensor de temperatura 6mm	34
11	8 711 006 060 0	Stecker	Plug	Connecteur	Spina	STEKKER NTC-VOELER ST...1E/SK 300/ST 75	Anection	16
12	8 718 006 775 0	Abdeckung hellgrau	Covering sheet light grey	Couvercle gris clair	Coperchio grigio chiaro	AFDEKKAP GRIJS VOOR FLENS BOILER	Chapa de protección girar claro	43
13	2 911 060 291 0	Schraube M10x25 (10x)	Screw M10x25 (10x)	Vis M10x25 (10x)	Vite M10x25 (10x)	Schroef M10x25 (10x)	Tornillo M10x25 (10x)	18
13	2 911 060 342 0	Schraube M12x30 (10x)	Screw M12x30 (10x)	Vis M12x30 (10x)	Vite M12x30 (10x)	Schroef M12x30 (10x)	Tornillo M12x30 (10x)	16
	8 710 402 029 0	Kappe	panel	Capot de protection	Tappo	beschermkapje	tapa	20
For:								

Ersatzteilliste  
Spare parts list  
Liste des pièces de rechange  
Lista parti di ricambio  
Onderdelenlijst  
Lista de repuestos

# SK 130-2 E - 7719001923

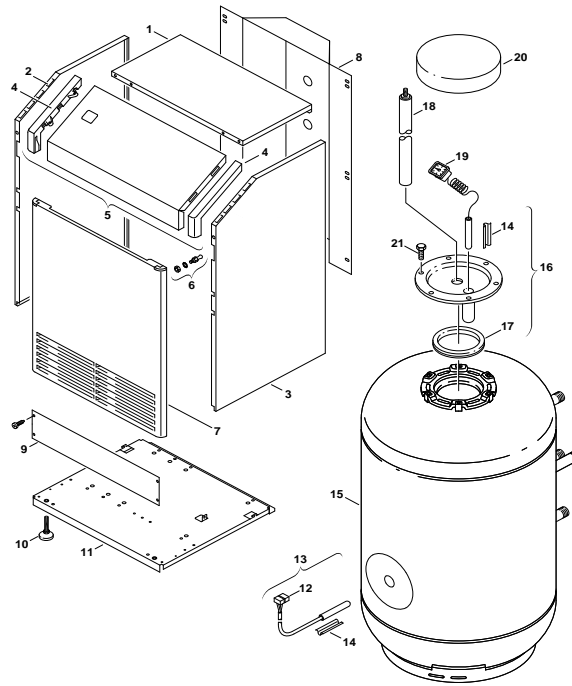

6720901216/G

Pos	Bestell-Nr.	Bezeichnung	Description	Dénomination	Descrizione	Benaming	Descripción	PG
1	8 711 304 664 0	Deckel weiß	Cover white	Couvercle blanc	Coperchio bianco	Deksel wit	Tapa blanco	36
2	8 729 010 650 0	Seitenwand links weiß	Side panel left white	Côté droit blanc	Pannelo laterale sinistra bianco	Zijpaneel links wit	Pared lateral izquierda blanco	38
3	8 729 010 649 0	Seitenwand rechts weiß	Side panel right white	Côté droit blanc	Pannelo laterale a destra bianco	Zijpaneel rechts wit	Pared lateral derecha blanco	38
4	8 729 010 723 0	Abschlußprofil-Satz	Final profile-set	Profil panneau lateral-kit	Final profile-set	Final profile-set	Final profile-set	36
5	8 715 506 246 0	Blende weiß	Screen white	Sachet caches	Mascherina bianco	Paneel wit	Chapa Cuadro blanco	39
6	8 729 010 801 0	Verschlusssatz	Lock set	Sachet de serrure	Coperchio	Afsluitingsset	Conjunto cerradura	22
7	8 729 010 652 0	Tür weiß	Door white	Porte blanc	Pannelo frontale bianco	Deur wit	Puerta blanco	41
8	8 715 402 226 0	Rückwand	Back_panel	Dosseret	Schienale	Achterwand	Respaldo	47
9	8 729 012 346 0	Traverse	Connection plate	Traverse	Traversa	Vangschaal	Placa de unión	33
10	8 713 401 046 0	Stellfuß	Foot	Pied	Vite	Voet	Pie	13
11	8 729 010 647 0	Bodenblech	Oven bottom	Tôle de fond	Lamiera di fondo	Bodemplaat	Chapa de fondo	42
12	8 711 006 060 0	Stecker	Plug	Connecteur	Spina	STECKER NTC-VOELER ST...1ESK 300ST 75	Anection	16
13	8 714 500 034 0	Sensor WW-NTC mit Aderendhülse 6m	Temperature sensor 6mm	SONDE DE TEMPERATURE 6mm	Sensore termometrico 6mm	Temperatuurvoeler 6mm	Sensor de temperatura 6mm	34
14	8 711 200 005 0	Klemmfeder	Clamp spring	Ressort	Fermo	Haarspeldveer	Muelle de tecla	13
15	8 729 012 344 0	Behälter	Reservoir	Réipient	Bollitore	Reservoir	Déposito	74
16	8 715 503 341 0	Flansch	Flange	Bride de raccordement	Flangia	Aansluitflens	Brida de conexión	40
17	8 710 103 513 0	Dichtung	Washer	Joint	Guarnizione	DICHTING ST 75	Junta	20
18	8 729 010 747 0	Anode	Anode	Anode	Anodo	Anode	Anodo	40
19	8 717 208 036 0	Thermometer	Thermometer	Thermomètre	Termometro	THERMOMETER SK...3Z-ST 110-E	Termómetro	37
20	8 729 012 350 0	Isolierung	Insulation	Isolation	Isolamento	Isolatie	Aislamiento	19
21	2 911 060 342 0	Schraube M12x30 (10x)	Screw M12x30 (10x)	Vis M12x30 (10x)	Vite M12x30 (10x)	Schroef M12x30 (10x)	Tornillo M12x30 (10x)	16

For:

Ersatzteilliste  
Spare parts list  
Liste des pièces de rechange  
Lista parti di ricambio  
Onderdelenlijst  
Lista de repuestos

## SK 130-2 E/C 2 - 7719002038

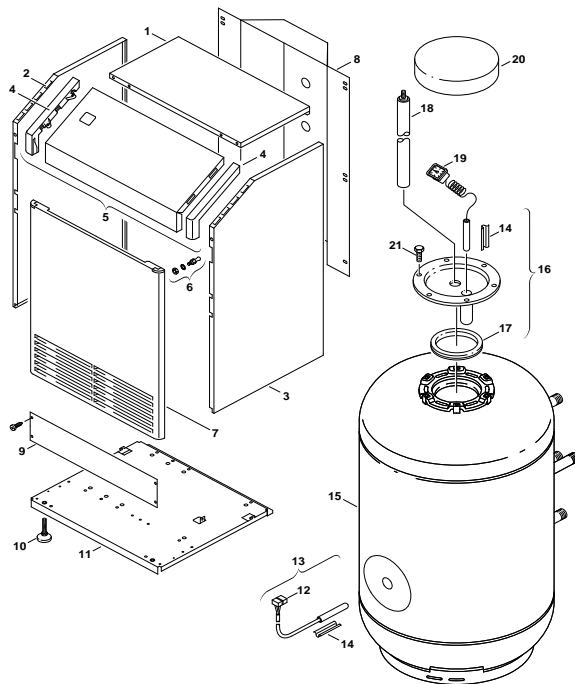

6720901216/G

Pos	Bestell-Nr.	Bezeichnung	Description	Dénomination	Descrizione	Benaming	Descripción	PG
1	8 711 304 734 0	Deckel gelb	Cover yellow	Couvercle jaune	Coperchio giallo	Deksel geel	Tapa amarilla	39
2	8 715 506 540 0	Seitenwand links gelb	Side panel left yellow	Côté droit jaune	Pannelo laterale sinistra giallo	Zijpaneel links geel	Pared lateral izquierda amarillo	42
3	8 715 506 541 0	Seitenwand rechts gelb	Side panel right yellow	Côté droit jaune	Pannelo laterale a destra giallo	Zijpaneel rechts geel	Pared lateral derecha amarillo	42
4	8 711 005 045 0	Blende silber	Shield silver	Sachet caches argent	Mascherina argento	Paneel zilver	Chapa cuadro plata	37
5	8 729 012 355 0	Blende silber	Shield silver	Sachet caches argent	Mascherina argento	Paneel zilver	Chapa cuadro plata	41
6	8 729 010 801 0	Verschlusssatz	Lock set	Sachet de serrure	Coperchio	Afsluitingsset	Conjunto cerradura	22
7	8 711 000 277 0	Tür silber	Door silver	Porte argent	Pannelo frontale argento	Deur zilver	Puerta plata	42
8	8 715 402 226 0	Rückwand	Back_panel	Dosseret	Schienale	Achterwand	Respaldo	47
9	8 729 012 346 0	Traverse	Connection plate	Traverse	Traversa	Vangschaal	Placa de unión	33
10	8 713 401 046 0	Stellfuß	Foot	Pied	Vite	Voet	Pie	13
11	8 729 010 647 0	Bodenblech	Oven bottom	Tôle de fond	Lamiera di fondo	Bodemplaat	Chapa de fondo	42
12	8 711 006 060 0	Stecker	Plug	Connecteur	Spina	STEKKER NTC-VOELER ST...1ESK 300ST 75	Anection	16
13	8 714 500 034 0	Sensor WW-NTC mit Aderendhülse 6m	Temperature sensor 6mm	SONDE DE TEMPERATURE 6mm	Sensore termometrico 6mm	Temperatuurvoeler 6mm	Sensor de temperatura 6mm	34
14	8 711 200 005 0	Klemmfeder	Clamp spring	Ressort	Fermo	Haarspeldveer	Muelle de tecla	13
15	8 729 012 344 0	Behälter	Reservoir	Réceptient	Bollitore	Reservoir	Déposito	74
16	8 715 503 341 0	Flansch	Flange	Bride de raccordement	Flangia	Aansluitflens	Brida de conexión	40
17	8 710 103 513 0	Dichtung	Washer	Joint	Guarnizione	DICHTING ST 75	Junta	20
18	8 729 010 747 0	Anode	Anode	Anode	Anodo	Anode	Anodo	40
19	8 717 208 036 0	Thermometer	Thermometer	Thermomètre	Termometro	THERMOMETER SK...3Z-ST 110-E	Termómetro	37
20	8 729 012 350 0	Isolierung	Insulation	Isolation	Isolamento	Isolatie	Aislamiento	19
21	2 911 060 342 0	Schraube M12x30 (10x)	Screw M12x30 (10x)	Vis M12x30 (10x)	Vite M12x30 (10x)	Schroef M12x30 (10x)	Tornillo M12x30 (10x)	16

For:

**Ersatzteilliste**  
**Spare parts list**  
**Liste des pièces de rechange**  
**Lista parti di ricambio**  
**Onderdelenlijst**  
**Lista de repuestos**

## SK 160-4 ZB - 7719001932

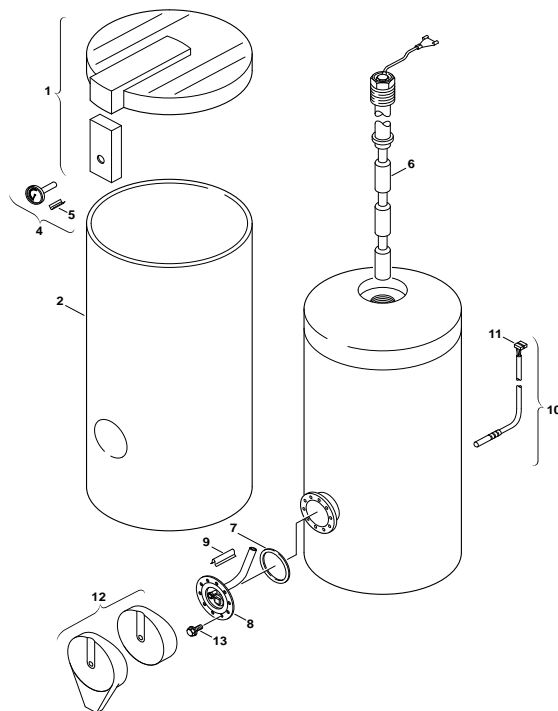

6720901190.AB/G

Pos	Bestell-Nr.	Bezeichnung	Description	Dénomination	Descrizione	Benaming	Descripción	PG
1	8 715 503 188 0	Haube hellgrau	Hood light grey	Carpot gris clair	Coperchio grigio chiaro	DEKSEL SK 160-4ZB (VOOR BOILER 771900193)	Capota girar claro	42
2	8 715 401 349 0	Mantel weiß	Shell white	Habillage blanc	Mantello bianco	MANTEL SK 160-4ZB (VOOR BOILER 771900193)	Carcasa blanco	47
4	8 717 208 050 0	Thermometer	Thermometer	Thermomètre	Termometro	Thermometer	Termómetro	31
5	8 714 606 024 0	Klemmfeder	Clamp spring	RESSORT POUR THERMOMETRE	Fermo	KLEMVEER V/THERMOMETRE ST/ISO	Muelle fijación	20
6	8 709 918 666 0	Anode 1"	Anode 1"	Anode 1"	Anodo 1"	ANODE (KETTING) ST120/160-1E /SK 130-3Z	Anodo 1"	43
7	8 710 103 096 0	Dichtungs-Set 100x109D - 115/138Dx3 (1x)	Set of seals 100x109D - 115/138Dx3 (1x)	Jeu de joints 100x109D - 115/138Dx3 (1x)	Set guarnizioni 100x109D - 115/138Dx3	DICHTING FLENS SK...ZZB-3ZB (VANAF 07/0)	conjunto de juntas 100x109D - 115/138Dx3	23
8	8 715 503 170 0	Flansch mit Tauchrohr kpl.	Connecting flange	Bride de raccordement	Flangia	FLENS + DICHTING SK - 3ZB	Conjunto brida y junta SK500	40
9	8 714 606 021 0	Klemmfeder	Clamp spring	Ressort	Fermo	KLEMVEER NTC SK120/140/160-4ZB	Muelle de tecla	25
10	8 714 500 034 0	Sensor WW-NTC mit Aderendhülse 6mm	Temperature sensor 6mm	SONDE DE TEMPERATURE 6mm	Sensore termometrico 6mm	Temperatuurvoeler 6mm	Sensor de temperatura 6mm	34
11	8 711 006 060 0	Stecker	Plug	Connecteur	Spina	STEKKER NTC-VOELER ST...1E/SK 300/ST 75	Anection	16
12	8 718 006 775 0	Abdeckung hellgrau	Covering sheet light grey	Couvercle gris clair	Coperchio grigio chiaro	AFDEKKAP GRIJS VOOR FLENS BOILER	Chapa de protección girar claro	43
13	2 911 060 291 0	Schraube M10x25 (10x)	Screw M10x25 (10x)	Vis M10x25 (10x)	Vite M10x25 (10x)	Schroef M10x25 (10x)	Tornillo M10x25 (10x)	18
13	2 911 060 342 0	Schraube M12x30 (10x)	Screw M12x30 (10x)	Vis M12x30 (10x)	Vite M12x30 (10x)	Schroef M12x30 (10x)	Tornillo M12x30 (10x)	16
	8 710 402 029 0	Kappe	panel	Capot de protection	Tappo	beschermkapje	tapa	20
For:								

Ersatzteilliste  
Spare parts list  
Liste des pièces de rechange  
Lista parti di ricambio  
Onderdelenlijst  
Lista de repuestos

SK 200-4 ZB - 7719001933

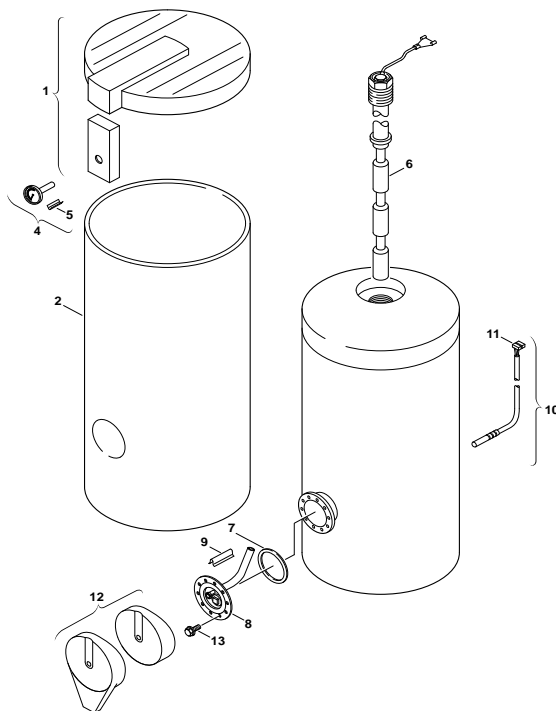

6720901190.AB/G

Pos	Bestell-Nr.	Bezeichnung	Description	Dénomination	Descrizione	Benaming	Descripción	PG
1	8 715 503 188 0	Haube hellgrau	Hood light grey	Capot gris clair	Coperchio grigio chiaro	DEKSEL SK 160-4ZB (VOOR BOILER 771900193)	Capota girar claro	42
2	8 715 401 350 0	Mantel weiß	Shell white	Habillage blanc	Mantello bianco	MANTEL SK 200-4ZB (VOOR BOILER 771900193)	Carcasa blanco	47
4	8 717 208 050 0	Thermometer	Thermometer	Thermomètre	Termometro	Thermometer	Termómetro	31
5	8 714 606 024 0	Klemmfeder	Clamp spring	RESSORT POUR THERMOMETRE	Fermo	KLEMVEER V/THERMOMETER ST/SO	Muelle fijación	20
6	8 709 918 638 0	Anode 1"	Anode 1"	Anode 1"	Anodo 1"	ANODE SK 120/140/160-4ZB	Anodo 1"	37
7	8 710 103 096 0	Dichtungs-Set 100x109D - 115/138Dx3 (1x)	Set of seals 100x109D - 115/138Dx3 (1x)	Jeu de joints 100x109D - 115/138Dx3 (1x)	Set guarnizioni 100x109D - 115/138Dx3	DICHTING FLENS SK...2ZB-3ZB (VANAF 070)	conjunto de juntas 100x109D - 115/138Dx3	23
8	8 715 503 170 0	Flansch mit Tauchrohr kpl.	Connecting flange	Bride de raccordement	Flangia	FLENS + DICHTING SK - 3ZB	Conjunto brida y junta SK500	40
9	8 714 606 021 0	Klemmfeder	Clamp spring	Ressort	Fermo	KLEMVEER NTC SK 120/140/160-4ZB	Muelle de tecla	25
10	8 714 500 034 0	Sensor WW-NTC mit Aderendhülse 6mm	Temperature sensor 6mm	SONDE DE TEMPERATURE 6mm	Sensore termometrico 6mm	Temperatuurvoeler 6mm	Sensor de temperatura 6mm	34
11	8 711 006 060 0	Stecker	Plug	Connecteur	Spina	STEKKER NTC-VOELER ST...1E/SK 300/ST 75	Anection	16
12	8 718 006 775 0	Abdeckung hellgrau	Covering sheet light grey	Couvercle gris clair	Coperchio grigio chiaro	AFDEKKAP GRUIS VOOR FLENS BOILER	Chapa de protección girar claro	43
13	2 911 060 291 0	Schraube M10x25 (10x)	Screw M10x25 (10x)	Vis M10x25 (10x)	Vite M10x25 (10x)	Schroef M10x25 (10x)	Tornillo M10x25 (10x)	18
13	2 911 060 342 0	Schraube M12x30 (10x)	Screw M12x30 (10x)	Vis M12x30 (10x)	Vite M12x30 (10x)	Schroef M12x30 (10x)	Tornillo M12x30 (10x)	16
	8 710 402 029 0	Kappe	panel	Capot de protection	Tappo	beschermkapje	tapa	20

For:

Ersatzteilliste  
Spare parts list  
Liste des pièces de rechange  
Lista parti di ricambio  
Onderdelenlijst  
Lista de repuestos

# SK 300 SOLAR - 7719001372

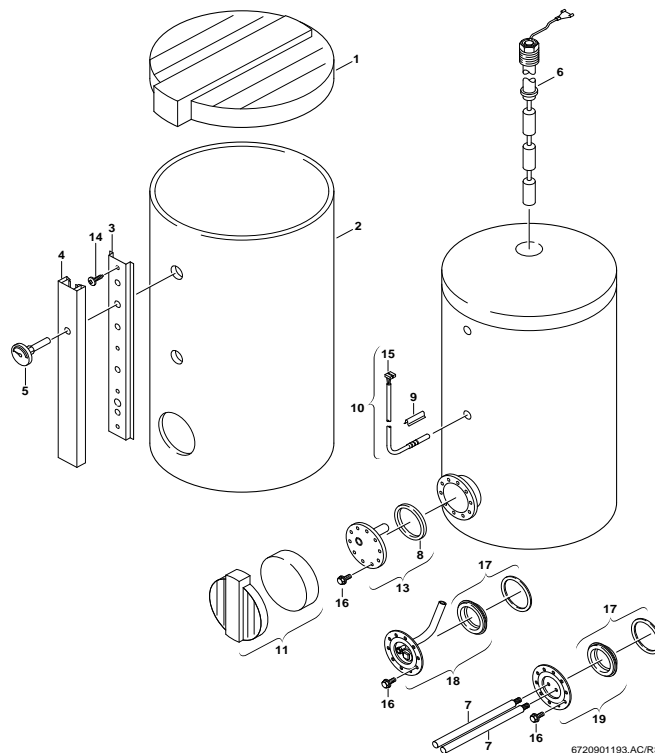

Pos	Bestell-Nr.	Bezeichnung	Description	Dénomination	Descrizione	Benaming	Descripción	PG
1	8 715 503 248 0	Haube grau	Hood grey	Capot gris	Carpot grigio	Deksel grijs	Tapa superior	42
1	8 715 503 437 0	Haube hellgrau	Hood light grey	Carpot gris clair	Coperchio grigio chiaro	Deksel lichtgrijs	Capota girar claro	42
2	8 715 401 302 0	Mantel weiß	Front shell white	Habillage blanc	Mantello bianco	MANTEL VOOR SK 300-3ZB (7719001369)	Carcasa blanco	47
3	8 718 005 563 0	Schiene	Frame	Structure	Telaio	Frame	Respaldo	31
4	8 715 503 251 0	Abdeckung grau	Covering sheet grey	Couvercle gris	Coperchio grigio	AFDEKPLAAT SK 300-3Z	Tapa	42
4	8 715 503 435 0	Abdeckung hellgrau	Covering sheet light grey	Couvercle gris clair	Coperchio grigio chiaro	Afdichting lichtgrijs	Chapa de protección girar claro	42
5	8 717 208 059 0	Thermometer	Thermometer	Thermomètre	Termometro	THERMOMETER SK 300-3ZB	Termómetro	38
6	8 709 918 666 0	Anode 1"	Anode 1"	Anode 1"	Anodo 1"	ANODE (KETTING) ST120/160-1E /SK 130-3Z	Anodo 1"	43
8	8 710 103 096 0	Dichtungs-Set 100x109D - 115/138Dx3 (1x)	Set of seals 100x109D - 115/138Dx3 (1x)	Jeu de joints 100x109D - 115/138Dx3 (1x)	Set guarnizioni 100x109D - 115/138Dx3	DICHTING FLENS SK...2ZB-3ZB (VANAF 070)	conjunto de juntas 100x109D - 115/138Dx3	23
8	8 710 103 145 0	Dichtring 190/245Dx3	Washer	Joint	Guarnizione	DICHTING FLENS SK 300-3ZB (TOT FD 07/03)	Anillo junta	30
9	8 714 606 021 0	Klemmfeder	Clamp spring	Ressort	Fermo	KLEIMVEER NTC SK120/A40/160-4ZB	Muelle de tecla	25
10	8 714 500 034 0	Sensor WW-NTC mit Aderendhülse 6m	Temperature sensor 6mm	SONDE DE TEMPERATURE 6mm	Sensore termometrico 6mm	Temperatuurvoeler 6mm	Sensor de temperatura 6mm	34
11	8 715 503 247 0	Abdeckung grau	Covering sheet grey	Couvercle gris	Coperchio grigio	Afdichting grijs	Chapa protección	40
11	8 715 503 436 0	Abdeckung hellgrau	Covering sheet light grey	Couvercle gris clair	Coperchio grigio chiaro	Afdichting lichtgrijs	Chapa de protección girar claro	40
13	8 715 503 252 0	Flansch	Connecting flange	Bride de raccordement	Flangia	FLENS SK 300-3ZB	Brida de conexión	47
14	8 713 403 008 0	Schraube (10x)	Screw	Vis (10x)	Vite (10x)	Schroef (10x)	Tornillo (10x)	11
15	8 711 006 060 0	Stecker	Plug	Connecteur	Spina	STEKKER NTC-VOELER ST...1ESK 300/ST 75	Anection	16
16	2 911 060 291 0	Schraube M10x25 (10x)	Screw M10x25 (10x)	Vis M10x25 (10x)	Vite M10x25 (10x)	Schroef M10x25 (10x)	Tornillo M10x25 (10x)	18
16	2 911 060 342 0	Schraube M12x30 (10x)	Screw M12x30 (10x)	Vis M12x30 (10x)	Vite M12x30 (10x)	Schroef M12x30 (10x)	Tornillo M12x30 (10x)	16
17	8 710 103 096 0	Dichtungs-Set 100x109D - 115/138Dx3 (1x)	Set of seals 100x109D - 115/138Dx3 (1x)	Jeu de joints 100x109D - 115/138Dx3 (1x)	Set guarnizioni 100x109D - 115/138Dx3	DICHTING FLENS SK...2ZB-3ZB (VANAF 070)	conjunto de juntas 100x109D - 115/138Dx3	23
18	8 715 503 170 0	Flansch mit Tauchrohr kpl.	Connecting flange	Bride de raccordement	Flangia	FLENS + DICHTING SK - 3ZB	Conjunto brida y junta SK500	40
	8 718 220 039 0	Hülse 1 1/4"	Sleeve 1 1/4"	Douille 1 1/4"	Bocchetta 1 1/4"	Bus 1 1/4"	Manguito 1 1/4"	09

For:



Ersatzteilliste  
Spare parts list  
Liste des pièces de rechange  
Lista parti di ricambio  
Onderdelenlijst  
Lista de repuestos

## SK 300-1 SOLAR - 7719001929

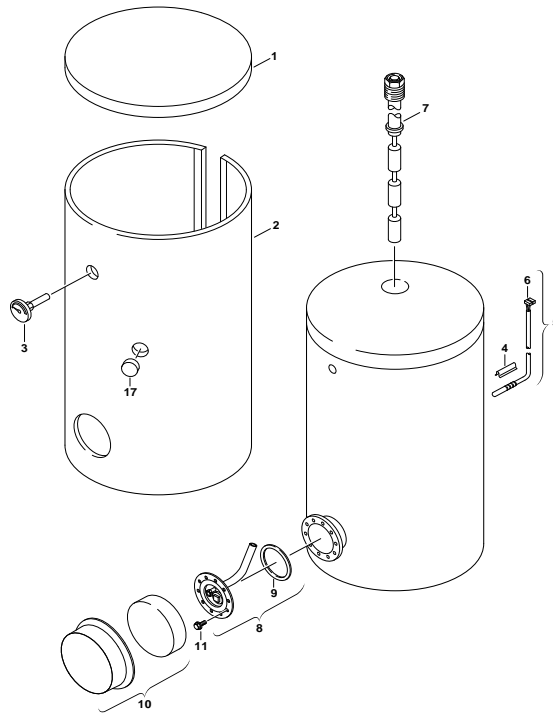

6720901194.AC/G

Pos	Bestell-Nr.	Bezeichnung	Description	Dénomination	Descrizione	Benaming	Descripción	PG
1	8 715 503 348 0	Haube hellgrau	Hood light grey	Carpot gris clair	Coperchio grigio chiaro	Deksel lichtgrijs	Capota girar claro	41
2	8 715 401 346 0	Mantel weiß	Shell white	Habillage blanc	Mantello bianco	MANTEL SK 300-1 SOLAR (7719001929)	Carcasa blanco	49
3	8 717 208 050 0	Thermometer	Thermometer	Thermomètre	Termometro	Thermometer	Termómetro	31
4	8 714 606 021 0	Klemmfeder	Clamp spring	Ressort	Fermo	KLEMMVEER NTC SK120/140/160-4ZB	Muelle de tecla	25
5	8 714 500 034 0	Sensor WW-NTC mit Aderendhülse 6m	Temperature sensor 6mm	SONDE DE TEMPERATURE 6mm	Sensore termometrico 6mm	Temperatuurvoeler 6mm	Sensor de temperatura 6mm	34
6	8 711 006 060 0	Stecker	Plug	Connecteur	Spina	STEKKER NTC-VOELER ST.-1E/SK 300ST 75	Anection	16
7	8 709 918 506 0	Anode	Anode	Anode	Anodo	ANODE SO 160-160/1-200-200/1-SK 180-300-	Anodo	43
7	8 709 918 666 0	Anode 1"	Anode 1"	Anode 1"	Anodo 1"	ANODE (KETTING) ST120/160-1E /SK 130-3Z	Anodo 1"	43
8	8 715 503 170 0	Flansch mit Tauchrohr kpl.	Connecting flange	Bride de raccordement	Flangia	FLENS + DICHTING SK - 3ZB	Conjunto brida y junta SK500	40
9	8 710 103 096 0	Dichtungs-Set 100x109D - 115/138Dx3 (1x)	Set of seals 100x109D - 115/138Dx3 (1x)	Jeu de joints 100x109D - 115/138Dx3 (1x)	Set guarnizioni 100x109D - 115/138Dx3	DICHTING FLENS SK..22B/-3ZB (VANAF 070)	conjunto de juntas 100x109D - 115/138Dx3	23
10	8 715 503 346 0	Abdeckung hellgrau	Covering sheet light grey	Couvercle gris clair	Coperchio grigio chiaro	DEKSEL SK 300-1/400-1/500-1 SOLAR	Chapa de protección girar claro	33
11	2 911 060 291 0	Schraube M10x25 (10x)	Screw M10x25 (10x)	Vis M10x25 (10x)	Vite M10x25 (10x)	Schroef M10x25 (10x)	Tornillo M10x25 (10x)	18
11	2 911 060 342 0	Schraube M12x30 (10x)	Screw M12x30 (10x)	Vis M12x30 (10x)	Vite M12x30 (10x)	Schroef M12x30 (10x)	Tornillo M12x30 (10x)	16
17	8 715 503 239 0	Isolierung	Insulation	Bouchon	Isolamento	ISOLATIE SK 300-1 SOLAR (7719001929)	Aislamiento	23
	8 718 220 038 0	Hülse 1"	Sleeve 1"	Douille 1"	Bocchetta 1"	ISOLATIE DEKSEL SK 300-1/400-1/500-1 SOL	Manguito 1"	09

For:

Ersatzteilliste  
 Spare parts list  
 Liste des pièces de rechange  
 Lista parti di ricambio  
 Onderdelenlijst  
 Lista de repuestos

# SK 300-1 solar - 8718541087

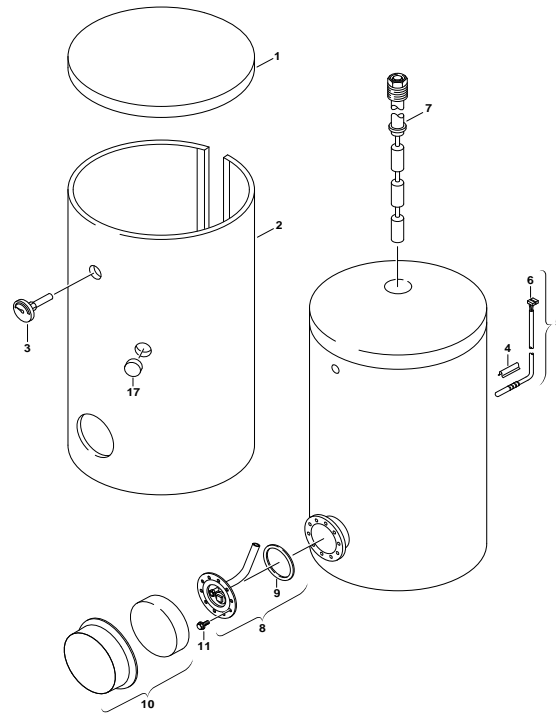

6720901194.AC/G

Pos	Bestell-Nr.	Bezeichnung	Description	Dénomination	Descrizione	Benaming	Descripción	PG
1	8 715 503 348 0	Haube hellgrau	Hood light grey	Carpot gris clair	Coperchio grigio chiaro	Deksel lichtgrijs	Capota girar claro	41
2	8 715 401 346 0	Mantel weiß	Shell white	Habillage blanc	Mantello bianco	MANTEL SK 300-1 SOLAR (7719001929)	Carcasa blanco	49
3	8 717 208 050 0	Thermometer	Thermometer	Thermomètre	Termometro	Thermometer	Termómetro	31
4	8 714 606 021 0	Klemmfeder	Clamp spring	Ressort	Fermo	KLEMVEER NTC SK120/140/160-4ZB	Muelle de tecla	25
5	8 714 500 034 0	Sensor WW-NTC mit Aderendhülse 6m	Temperature sensor 6mm	SONDE DE TEMPERATURE 6mm	Sensore termometrico 6mm	Temperatuurvoeler 6mm	Sensor de temperatura 6mm	34
6	8 711 006 060 0	Stecker	Plug	Connecteur	Spina	STEKKER NTC-VOELER ST.-1E/SK 300ST 75	Anection	16
7	8 709 918 506 0	Anode	Anode	Anode	Anodo	ANODE SO 160-160/1-200-200/1-SK 180-300-	Anodo	43
7	8 709 918 666 0	Anode 1"	Anode 1"	Anode 1"	Anodo 1"	ANODE (KETTING)ST120/160-1E /SK 130-3Z	Anodo 1"	43
8	8 715 503 170 0	Flansch mit Tauchrohr kpl.	Connecting flange	Bride de raccordement	Flangia	FLENS + DICHTING SK - 3ZB	Conjunto brida y junta SK500	40
9	8 710 103 096 0	Dichtungs-Set 100x109D - 115/138Dx3 (1x)	Set of seals 100x109D - 115/138Dx3 (1x)	Jeu de joints 100x109D - 115/138Dx3 (1x)	Set guarnizioni 100x109D - 115/138Dx3	DICHTING FLENS SK.-2ZB/3ZB (VANAF 070)	conjunto de juntas 100x109D - 115/138Dx3	23
10	8 715 503 346 0	Abdeckung hellgrau	Covering sheet light grey	Couvercle gris clair	Coperchio grigio chiaro	DEKSEL SK 300-1/400-1/500-1 SOLAR	Chapa de protección girar claro	33
11	2 911 060 291 0	Schraube M10x25 (10x)	Screw M10x25 (10x)	Vis M10x25 (10x)	Vite M10x25 (10x)	Schroef M10x25 (10x)	Tornillo M10x25 (10x)	18
11	2 911 060 342 0	Schraube M12x30 (10x)	Screw M12x30 (10x)	Vis M12x30 (10x)	Vite M12x30 (10x)	Schroef M12x30 (10x)	Tornillo M12x30 (10x)	16
17	8 715 503 239 0	Isolierung	Insulation	Bouchon	Isolamento	ISOLATIE SK 300-1 SOLAR (7719001929)	Aislamiento	23
	8 718 220 038 0	Hülse 1"	Sleeve 1"	Douille 1"	Bocchetta 1"	ISOLATIE DEKSEL SK 300-1/400-1/500-1 SOL	Manguito 1"	09

For:

**Ersatzteilliste**  
**Spare parts list**  
**Liste des pièces de rechange**  
**Lista parti di ricambio**  
**Onderdelenlijst**  
**Lista de repuestos**

# SK 300-1 SOLAR/C 2 - 7719002125

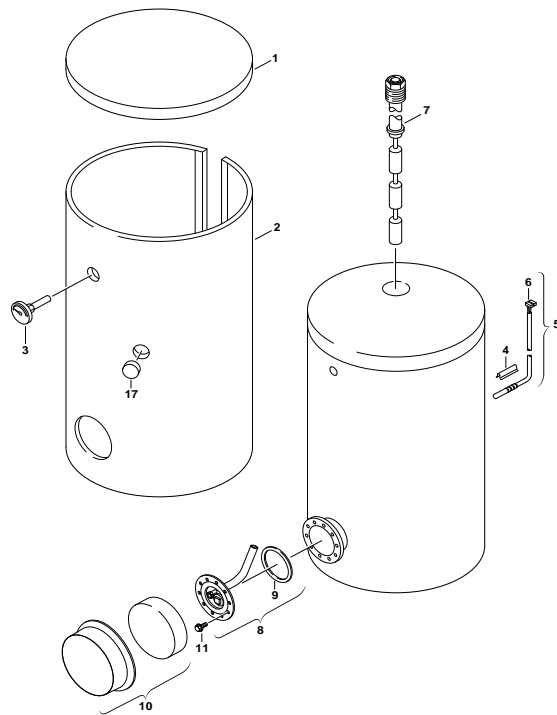

6720901194.AC/G

Pos	Bestell-Nr.	Bezeichnung	Description	Dénomination	Descrizione	Benaming	Descripción	PG
1	8 715 503 419 0	Haube silbergrau	HOOD SILVER GREY	Carpot argent gris	Coperchio argentato grigio	Deksel zilvergrijs	Hood silver grey	41
2	8 715 401 393 0	Mantel silbergrau	Front shell silver grey	Habillage argent gris	Mantello argentato grigio	Mantel zilver grijs	Carcasa plata girar	49
3	8 717 208 050 0	Thermometer	Thermometer	Thermomètre	Termometro	Thermometer	Termómetro	31
4	8 714 606 021 0	Klemmfeder	Clamp spring	Ressort	Fermo	KLEMVEER NTC SK120/140/160-4ZB	Muelle de tecla	25
5	8 714 500 034 0	Sensor WW-NTC mit Aderendhülse 6mm	Temperature sensor 6mm	SONDE DE TEMPERATURE 6mm	Sensore termometrico 6mm	Temperatuurvoeler 6mm	Sensor de temperatura 6mm	34
6	8 711 006 060 0	Stecker	Plug	Connecteur	Spina	STEKKER NTC-VOELER ST.-1E/SK 300ST 75	Anection	16
7	8 709 918 506 0	Anode	Anode	Anode	Anodo	ANODE SO 160-160/1-200-200/1-SK 180-300-	Anodo	43
7	8 709 918 666 0	Anode 1"	Anode 1"	Anode 1"	Anodo 1"	ANODE (KETTING) ST120/160-1E/SK 130-3Z	Anodo 1"	43
8	8 715 503 170 0	Flansch mit Tauchrohr kpl.	Connecting flange	Bride de raccordement	Flangia	FLENS + DICHTING SK - 3ZB	Conjunto brida y junta SK500	40
9	8 710 103 096 0	Dichtungs-Set 100x109D - 115/138Dx3 (1x)	Set of seals 100x109D - 115/138Dx3 (1x)	Jeu de joints 100x109D - 115/138Dx3 (1x)	Set guarnizioni 100x109D - 115/138Dx3	DICHTING FLENS SK.-2ZB/3ZB (VANAF 070)	conjunto de juntas 100x109D - 115/138Dx3	23
10	8 715 503 424 0	Abdeckung gelb	Covering sheet yellow	Couvercle jaune	Coperchio giallo	Afdichting geel	Chapa de protección amarillo	33
11	2 911 060 291 0	Schraube M10x25 (10x)	Screw M10x25 (10x)	Vis M10x25 (10x)	Vite M10x25 (10x)	Schroef M10x25 (10x)	Tornillo M10x25 (10x)	18
11	2 911 060 342 0	Schraube M12x30 (10x)	Screw M12x30 (10x)	Vis M12x30 (10x)	Vite M12x30 (10x)	Schroef M12x30 (10x)	Tornillo M12x30 (10x)	16
17	8 715 503 239 0	Isolierung	Insulation	Bouchon	Isolamento	ISOLATIE SK 300-1 SOLAR (7719001929)	Aislamiento	23
	8 718 220 038 0	Hülse 1"	Sleeve 1"	Douille 1"	Bocchetta 1"	ISOLATIE DEKSEL SK 300-1/400-1/500-1 SOL	Manguito 1"	09

For:

Ersatzteilliste  
Spare parts list  
Liste des pièces de rechange  
Lista parti di ricambio  
Onderdelenlijst  
Lista de repuestos

# SK 300-3 ZB - 7719001369

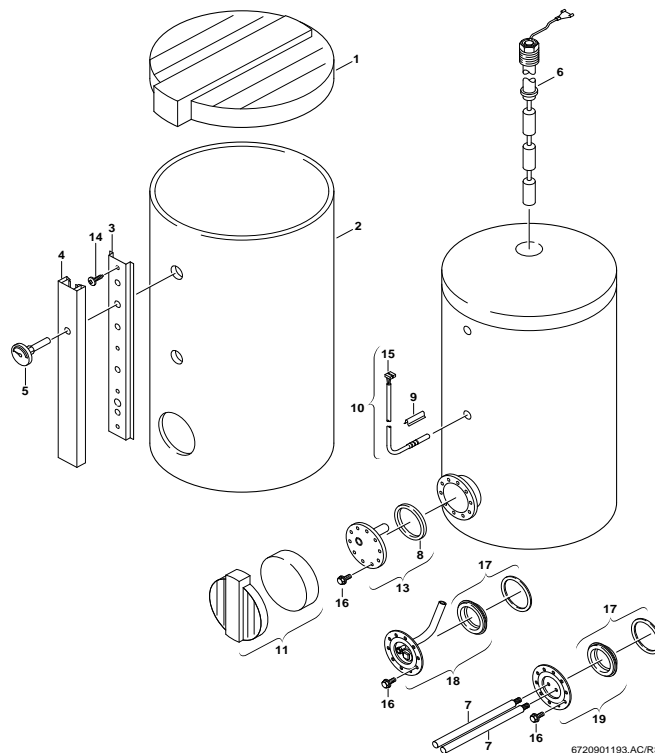

Pos	Bestell-Nr.	Bezeichnung	Description	Dénomination	Descrizione	Benaming	Descripción	PG
1	8 715 503 248 0	Haube grau	Hood grey	Capot gris	Carpot grigio	Deksel grijs	Tapa superior	42
1	8 715 503 437 0	Haube hellgrau	Hood light grey	Carpot gris clair	Coperchio grigio chiaro	Deksel lichtgrijs	Capota girar claro	42
2	8 715 401 302 0	Mantel weiß	Front shell white	Habillage blanc	Mantello bianco	MANTEL VOOR SK 300-3 ZB (7719001369)	Carcasa blanco	47
3	8 718 005 563 0	Schiene	Frame	Structure	Telaio	Frame	Respaldo	31
4	8 715 503 251 0	Abdeckung grau	Covering sheet grey	Couvercle gris	Coperchio grigio	AFDEKPLAAT SK 300-3Z	Tapa	42
4	8 715 503 435 0	Abdeckung hellgrau	Covering sheet light grey	Couvercle gris clair	Coperchio grigio chiaro	Afdichting lichtgrijs	Chapa de protección girar claro	42
5	8 717 208 059 0	Thermometer	Thermometer	Thermomètre	Termometro	THERMOMETER SK 300-3ZB	Termómetro	38
6	8 709 918 666 0	Anode 1"	Anode 1"	Anode 1"	Anodo 1"	ANODE (KETTING) ST120/160-1E /SK 130-3Z	Anodo 1"	43
8	8 710 103 096 0	Dichtungs-Set 100x109D - 115/138Dx3 (1x)	Set of seals 100x109D - 115/138Dx3 (1x)	Jeu de joints 100x109D - 115/138Dx3 (1x)	Set guarnizioni 100x109D - 115/138Dx3	DICHTING FLENS SK - 22B/-3ZB (VANAF 070)	conjunto de juntas 100x109D - 115/138Dx3	23
8	8 710 103 145 0	Dichtring 190/245Dx3	Washer	Joint	Guarnizione	DICHTING FLENS SK 300-3ZB (TOT FD 07/03)	Anillo junta	30
9	8 714 606 021 0	Klemmfeder	Clamp spring	Ressort	Fermo	KLEIMVEER NTC SK120/A40/160-4ZB	Muelle de tecla	25
10	8 714 500 034 0	Sensor WW-NTC mit Aderendhülse 6m	Temperature sensor 6mm	SONDE DE TEMPERATURE 6mm	Sensore termometrico 6mm	Temperatuurvoeler 6mm	Sensor de temperatura 6mm	34
11	8 715 503 247 0	Abdeckung grau	Covering sheet grey	Couvercle gris	Coperchio grigio	Afdichting grijs	Chapa protección	40
11	8 715 503 436 0	Abdeckung hellgrau	Covering sheet light grey	Couvercle gris clair	Coperchio grigio chiaro	Afdichting lichtgrijs	Chapa de protección girar claro	40
13	8 715 503 252 0	Flansch	Connecting flange	Bride de raccordement	Flangia	FLENS SK 300-3ZB	Brida de conexión	47
14	8 713 403 008 0	Schraube (10x)	Screw	Vis (10x)	Vite (10x)	Schroef (10x)	Tornillo (10x)	11
15	8 711 006 060 0	Stecker	Plug	Connecteur	Spina	STEKKER NTC-VOELER ST...1ESK 300/ST 75	Anection	16
16	2 911 060 291 0	Schraube M10x25 (10x)	Screw M10x25 (10x)	Vis M10x25 (10x)	Vite M10x25 (10x)	Schroef M10x25 (10x)	Tornillo M10x25 (10x)	18
16	2 911 060 342 0	Schraube M12x30 (10x)	Screw M12x30 (10x)	Vis M12x30 (10x)	Vite M12x30 (10x)	Schroef M12x30 (10x)	Tornillo M12x30 (10x)	16
17	8 710 103 096 0	Dichtungs-Set 100x109D - 115/138Dx3 (1x)	Set of seals 100x109D - 115/138Dx3 (1x)	Jeu de joints 100x109D - 115/138Dx3 (1x)	Set guarnizioni 100x109D - 115/138Dx3	DICHTING FLENS SK - 22B/-3ZB (VANAF 070)	conjunto de juntas 100x109D - 115/138Dx3	23
18	8 715 503 170 0	Flansch mit Tauchrohr kpl.	Connecting flange	Bride de raccordement	Flangia	FLENS + DICHTING SK - 3ZB	Conjunto brida y junta SK500	40
	8 718 220 039 0	Hülse 1 1/4"	Sleeve 1 1/4"	Douille 1 1/4"	Bocchetta 1 1/4"	Bus 1 1/4"	Manguito 1 1/4"	09

For:

Ersatzteilliste  
Spare parts list  
Liste des pièces de rechange  
Lista parti di ricambio  
Onderdelenlijst  
Lista de repuestos

# SK 400-1 SOLAR - 7719001930

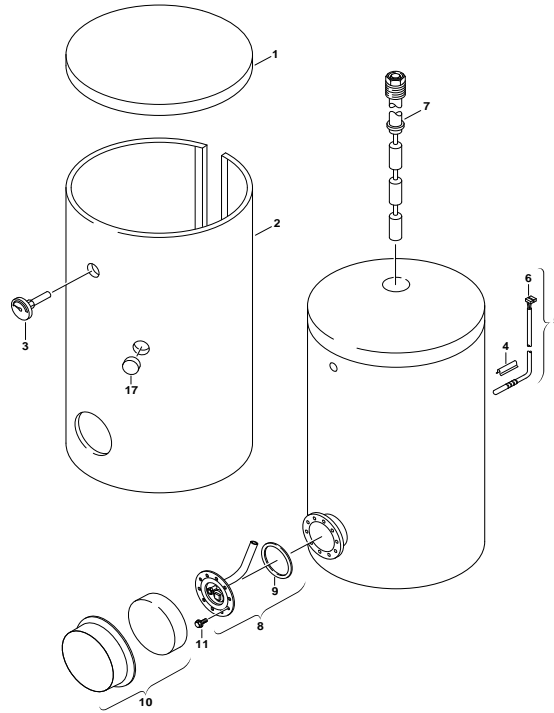

6720901194.AC/G

Pos	Bestell-Nr.	Bezeichnung	Description	Dénomination	Descrizione	Benaming	Descripción	PG
1	8 715 503 345 0	Haube hellgrau	Hood light grey	Carpot gris clair	Coperchio grigio chiaro	Deksel lichtgrijs	Capota gris claro	41
2	8 715 401 303 0	Mantel weiß	Shell white	HABILLAGE BLANC SH370	Mantello bianco	Mantel wit	Carcasa blanco	51
3	8 717 208 050 0	Thermometer	Thermometer	Thermomètre	Termometro	Thermometer	Termómetro	31
4	8 714 606 021 0	Klemmfeder	Clamp spring	R ressort	Fermo	KLEEMVEER NTC SK120/140/160-4ZB	Muelle de tecla	25
5	8 714 500 034 0	Sensor WW-NTC mit Aderendhülse 6mm	Temperature sensor 6mm	SONDE DE TEMPERATURE 6mm	Sensore termometrico 6mm	Temperatuurvoeler 6mm	Sensor de temperatura 6mm	34
6	8 711 006 060 0	Stecker	Plug	Connecteur	Spina	STEKKER NTC-VOELER ST.-1ESK 300ST 75	Aneccion	16
7	8 709 918 506 0	Anode	Anode	Anode	Anodo	ANODE SO 160-160/1-200-200/1-SK 180-300-	Anodo	43
7	8 709 918 666 0	Anode 1"	Anode 1"	Anode 1"	Anodo 1"	ANODE (KETTING) ST120/160-1E/ISK 130-3Z	Anodo 1"	43
8	8 715 503 170 0	Flansch mit Tauchrohr kpl.	Connecting flange	Bride de raccordement	Flangia	FLENS + DICHTING SK - 3ZB	Conjunto brida y junta SK500	40
9	8 710 103 096 0	Dichtungs-Set 100x109D - 115/138Dx3 (1x)	Set of seals 100x109D - 115/138Dx3 (1x)	Jeu de joints 100x109D - 115/138Dx3 (1x)	Set guarnizioni 100x109D - 115/138Dx3	DICHTING FLENS SK..2ZB-3ZB (VANAF 070)	conjunto de juntas 100x109D - 115/138Dx3	23
10	8 715 503 346 0	Abdeckung hellgrau	Covering sheet light grey	Couvercle gris clair	Coperchio grigio chiaro	DEKSEL SK 300-1/400-1/500-1 SOLAR	Chapa de protección girar claro	33
11	2 911 060 291 0	Schraube M10x25 (10x)	Screw M10x25 (10x)	Vis M10x25 (10x)	Vite M10x25 (10x)	Schroef M10x25 (10x)	Tornillo M10x25 (10x)	18
11	2 911 060 342 0	Schraube M12x30 (10x)	Screw M12x30 (10x)	Vis M12x30 (10x)	Vite M12x30 (10x)	Schroef M12x30 (10x)	Tornillo M12x30 (10x)	16
17	8 715 503 239 0	Isolierung	Insulation	Bouchon	Isolamento	ISOLATIE SK 300-1 SOLAR (7719001929)	Aislamiento	23
	8 718 220 038 0	Hülse 1"	Sleeve 1"	Douille 1"	Bocchetta 1"	ISOLATIE DEKSEL SK 300-1/400-1/500-1 SOL.	Manguito 1"	09
For:								

Ersatzteilliste  
 Spare parts list  
 Liste des pièces de rechange  
 Lista parti di ricambio  
 Onderdelenlijst  
 Lista de repuestos

# SK 400-1 solar - 8718541090

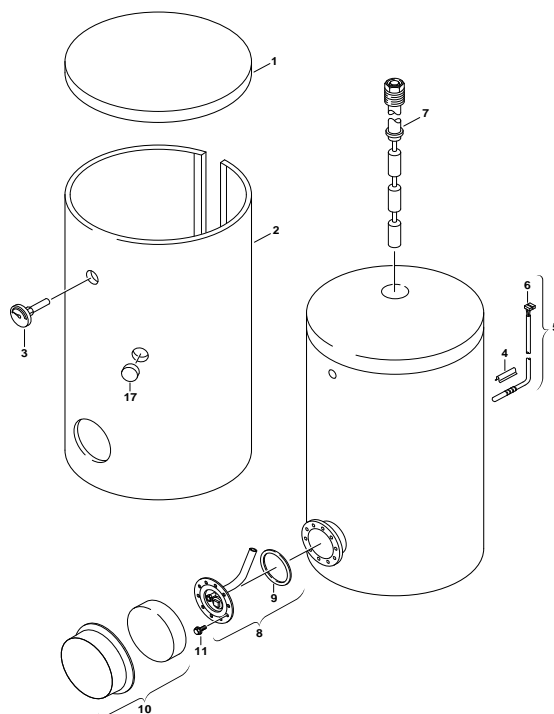

6720901194.AC/G

Pos	Bestell-Nr.	Bezeichnung	Description	Dénomination	Descrizione	Benaming	Descripción	PG
1	<b>8 715 503 345 0</b>	Haube hellgrau	Hood light grey	Carpot gris clair	Coperchio grigio chiaro	Deksel lichtgrijs	Capota gris claro	41
2	<b>8 715 401 303 0</b>	Mantel weiß	Shell white	HABILLAGE BLANC SH370	Mantello bianco	Mantel wit	Carcasa blanco	51
3	<b>8 717 208 050 0</b>	Thermometer	Thermometer	Thermomètre	Termometro	Thermometer	Termómetro	31
4	<b>8 714 606 021 0</b>	Klemmfeder	Clamp spring	Ressort	Fermo	KLEEMVEER NTC SK120/140/160-4ZB	Muelle de tecla	25
5	<b>8 714 500 034 0</b>	Sensor WW-NTC mit Aderendhülse 6mm	Temperature sensor 6mm	SONDE DE TEMPERATURE 6mm	Sensore termometrico 6mm	Temperatuurvoeler 6mm	Sensor de temperatura 6mm	34
6	<b>8 711 006 060 0</b>	Stecker	Plug	Connecteur	Spina	STEKKER NTC-VOELER ST.-1E/SK 300ST 75	Anection	16
7	<b>8 709 918 506 0</b>	Anode	Anode	Anode	Anodo	ANODE SO 160-160/1-200-200/1-SK 180-300-	Anodo	43
7	<b>8 709 918 666 0</b>	Anode 1"	Anode 1"	Anode 1"	Anodo 1"	ANODE (KETTING)ST120/160-1E/SK 130-3Z	Anodo 1"	43
8	<b>8 715 503 170 0</b>	Flansch mit Tauchrohr kpl.	Connecting flange	Bride de raccordement	Flangia	FLENS + DICHTING SK - 3ZB	Conjunto brida y junta SK500	40
9	<b>8 710 103 096 0</b>	Dichtungs-Set 100x109D - 115/138Dx3 (1x)	Set of seals 100x109D - 115/138Dx3 (1x)	Jeu de joints 100x109D - 115/138Dx3 (1x)	Set guarnizioni 100x109D - 115/138Dx3	DICHTING FLENS SK.-2ZB-3ZB (VANAF 070)	conjunto de juntas 100x109D - 115/138Dx3	23
10	<b>8 715 503 346 0</b>	Abdeckung hellgrau	Covering sheet light grey	Couvercle gris clair	Coperchio grigio chiaro	DEKSEL SK 300-1/400-1/500-1 SOLAR	Chapa de protección girar claro	33
11	<b>2 911 060 291 0</b>	Schraube M10x25 (10x)	Screw M10x25 (10x)	Vis M10x25 (10x)	Vite M10x25 (10x)	Schroef M10x25 (10x)	Tornillo M10x25 (10x)	18
11	<b>2 911 060 342 0</b>	Schraube M12x30 (10x)	Screw M12x30 (10x)	Vis M12x30 (10x)	Vite M12x30 (10x)	Schroef M12x30 (10x)	Tornillo M12x30 (10x)	16
17	<b>8 715 503 239 0</b>	Isolierung	Insulation	Bouchon	Isolamento	ISOLATIE SK 300-1 SOLAR (7719001929)	Aislamiento	23
	<b>8 718 220 038 0</b>	Hülse 1"	Sleeve 1"	Douille 1"	Bocchetta 1"	ISOLATIE DEKSEL SK 300-1/400-1/500-1 SOLAR	Manguito 1"	09

For:

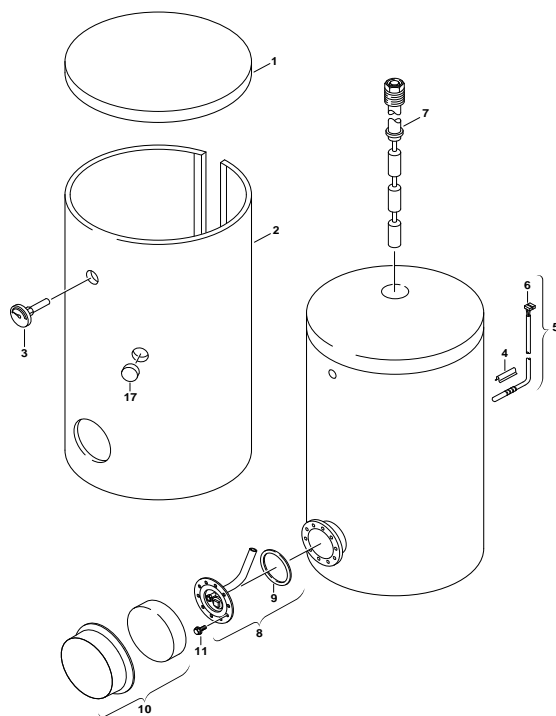
**Ersatzteilliste****Spare parts list****Liste des pièces de rechange****Lista parti di ricambio****Onderdelenlijst****Lista de repuestos****SK 400-1 SOLAR/C 2 - 7719002126**

6720901194.AC/G

Pos	Bestell-Nr.	Bezeichnung	Description	Dénomination	Descrizione	Benaming	Descripción	PG
1	8 715 503 420 0	Haube silbergrau	HOOD SILVER GREY	Carpot argent gris	Coperchio argentato grigio	Deksel zilvergrijs	Hood silver grey	41
2	8 715 401 391 0	Mantel silbergrau	Front shell silver grey	Habillage argent gris	Mantello argentato grigio	Mantel zilver grijs	Carcasa plata girar	51
3	8 717 208 050 0	Thermometer	Thermometer	Thermomètre	Termometro	Thermometer	Termómetro	31
4	8 714 606 021 0	Klemmfeder	Clamp spring	Ressort	Fermo	KLEEMVEER NTC SK120/140/160-4ZB	Muelle de tecla	25
5	8 714 500 034 0	Sensor WW-NTC mit Aderendhülse 6m	Temperature sensor 6mm	SONDE DE TEMPERATURE 6mm	Sensore termometrico 6mm	Temperatuurvoeler 6mm	Sensor de temperatura 6mm	34
6	8 711 006 060 0	Stecker	Plug	Connecteur	Spina	STEKKER NTC-VOELER ST.-1E/SK 300ST 75	Anection	16
7	8 709 918 506 0	Anode	Anode	Anode	Anodo	ANODE SO 160-160/1-200-200/1-SK 180-300-	Anodo	43
7	8 709 918 666 0	Anode 1"	Anode 1"	Anode 1"	Anodo 1"	ANODE (KETTING) ST120/160-1E /SK 130-3Z	Anodo 1"	43
8	8 715 503 170 0	Flansch mit Tauchrohr kpl.	Connecting flange	Bride de raccordement	Flangia	FLENS + DICHTING SK - 3ZB	Conjunto brida y junta SK500	40
9	8 710 103 096 0	Dichtungs-Set 100x109D - 115/138Dx3 (1x)	Set of seals 100x109D - 115/138Dx3 (1x)	Jeu de joints 100x109D - 115/138Dx3 (1x)	Set guarnizioni 100x109D - 115/138Dx3	DICHTING FLENS SK.-2ZB-3ZB (VANAF 070)	conjunto de juntas 100x109D - 115/138Dx3	23
10	8 715 503 424 0	Abdeckung gelb	Covering sheet yellow	Couvercle jaune	Coperchio giallo	Afdichting geel	Chapa de protección amarillo	33
11	2 911 060 291 0	Schraube M10x25 (10x)	Screw M10x25 (10x)	Vis M10x25 (10x)	Vite M10x25 (10x)	Schroef M10x25 (10x)	Tornillo M10x25 (10x)	18
11	2 911 060 342 0	Schraube M12x30 (10x)	Screw M12x30 (10x)	Vis M12x30 (10x)	Vite M12x30 (10x)	Schroef M12x30 (10x)	Tornillo M12x30 (10x)	16
17	8 715 503 239 0	Isolierung	Insulation	Bouchon	Isolamento	ISOLATIE SK 300-1 SOLAR (7719001929)	Aislamiento	23
	8 718 220 038 0	Hülse 1"	Sleeve 1"	Douille 1"	Bocchetta 1"	ISOLATIE DEKSEL SK 300-1/400-1/500-1 SOL	Manguito 1"	09
For:								

Ersatzteilliste  
Spare parts list  
Liste des pièces de rechange  
Lista parti di ricambio  
Onderdelenlijst  
Lista de repuestos

# SK 400-3 ZB - 7719001370

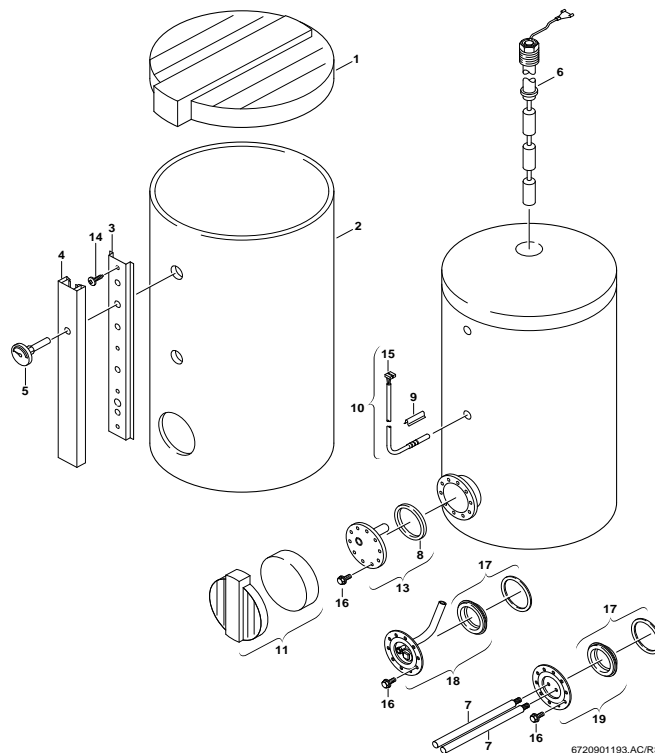

Pos	Bestell-Nr.	Bezeichnung	Description	Dénomination	Descrizione	Benaming	Descripción	PG
1	8 715 503 248 0	Haube grau	Hood grey	Capot gris	Carpot grigio	Deksel grijs	Tapa superior	42
1	8 715 503 437 0	Haube hellgrau	Hood light grey	Carpot gris clair	Coperchio grigio chiaro	Deksel lichtgrijs	Capota girar claro	42
2	8 715 401 303 0	Mantel weiß	Shell white	HABILLAGE BLANC SH370	Mantello bianco	Mantel wit	Carcasa blanco	51
3	8 718 005 564 0	Schiene	Frame	Structure	Telaio	Frame	Respaldo	32
4	8 715 503 251 0	Abdeckung grau	Covering sheet grey	Couvercle gris	Coperchio grigio	AFDEKPLAAT SK 300-3Z	Tapa	42
4	8 715 503 435 0	Abdeckung hellgrau	Covering sheet light grey	Couvercle gris clair	Coperchio grigio chiaro	Afdichting lichtgrijs	Chapa de protección girar claro	42
5	8 717 208 059 0	Thermometer	Thermometer	Thermomètre	Termometro	THERMOMETER SK 300-3ZB	Termómetro	38
6	8 709 918 666 0	Anode 1"	Anode 1"	Anode 1"	Anodo 1"	ANODE (KETTING) ST120/160-1E /SK 130-3Z	Anodo 1"	43
8	8 710 103 096 0	Dichtungs-Set 100x109D - 115/138Dx3 (1x)	Set of seals 100x109D - 115/138Dx3 (1x)	Jeu de joints 100x109D - 115/138Dx3 (1x)	Set guarnizioni 100x109D - 115/138Dx3	DICHTING FLENS SK - 22B-3ZB (VANAF 070)	conjunto de juntas 100x109D - 115/138Dx3	23
8	8 710 103 145 0	Dichtring 190/245Dx3	Washer	Joint	Guarnizione	DICHTING FLENS SK 300-3ZB (TOT FD 07/03)	Anillo junta	30
9	8 714 606 021 0	Klemmfeder	Clamp spring	Ressort	Fermo	KLEM/VEER NTC SK120/A40/160-4ZB	Muelle de tecla	25
10	8 714 500 034 0	Sensor WW-NTC mit Aderendhülse 6m	Temperature sensor 6mm	SONDE DE TEMPERATURE 6mm	Sensore termometrico 6mm	Temperatuurvoeler 6mm	Sensor de temperatura 6mm	34
11	8 715 503 247 0	Abdeckung grau	Covering sheet grey	Couvercle gris	Coperchio grigio	Afdichting grijs	Chapa protección	40
11	8 715 503 436 0	Abdeckung hellgrau	Covering sheet light grey	Couvercle gris clair	Coperchio grigio chiaro	Afdichting lichtgrijs	Chapa de protección girar claro	40
13	8 715 503 252 0	Flansch	Connecting flange	Bride de raccordement	Flangia	FLENS SK 300-3ZB	Brida de conexión	47
14	8 713 403 008 0	Schraube (10x)	Screw	Vis (10x)	Vite (10x)	Schroef (10x)	Tornillo (10x)	11
15	8 711 006 060 0	Stecker	Plug	Connecteur	Spina	STEKKER NTC-VOELER ST...1ESK 300/ST 75	Anection	16
16	2 911 060 291 0	Schraube M10x25 (10x)	Screw M10x25 (10x)	Vis M10x25 (10x)	Vite M10x25 (10x)	Schroef M10x25 (10x)	Tornillo M10x25 (10x)	18
16	2 911 060 342 0	Schraube M12x30 (10x)	Screw M12x30 (10x)	Vis M12x30 (10x)	Vite M12x30 (10x)	Schroef M12x30 (10x)	Tornillo M12x30 (10x)	16
17	8 710 103 096 0	Dichtungs-Set 100x109D - 115/138Dx3 (1x)	Set of seals 100x109D - 115/138Dx3 (1x)	Jeu de joints 100x109D - 115/138Dx3 (1x)	Set guarnizioni 100x109D - 115/138Dx3	DICHTING FLENS SK - 22B-3ZB (VANAF 070)	conjunto de juntas 100x109D - 115/138Dx3	23
18	8 715 503 170 0	Flansch mit Tauchrohr kpl.	Connecting flange	Bride de raccordement	Flangia	FLENS + DICHTING SK - 3ZB	Conjunto brida y junta SK500	40
	8 718 220 039 0	Hülse 1 1/4"	Sleeve 1 1/4"	Douille 1 1/4"	Bocchetta 1 1/4"	Bus 1 1/4"	Manguito 1 1/4"	09

For:



Ersatzteilliste  
Spare parts list  
Liste des pièces de rechange  
Lista parti di ricambio  
Onderdelenlijst  
Lista de repuestos

# SK 500-1 SOLAR - 7739300188

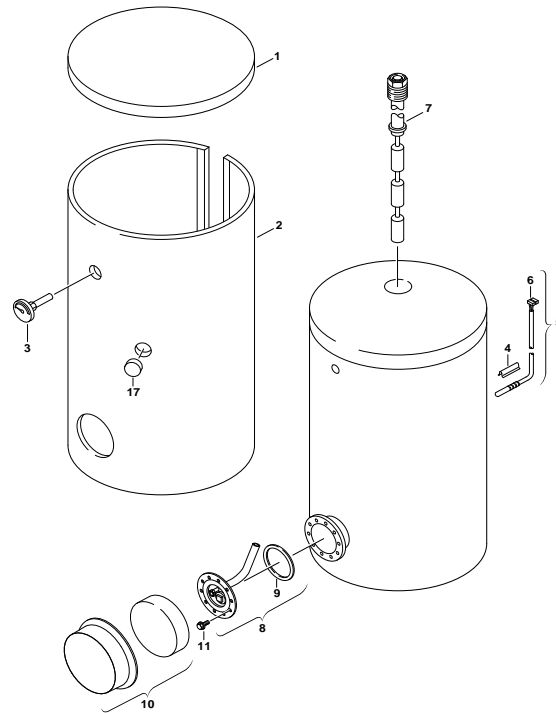

6720901194.AC/G

Pos	Bestell-Nr.	Bezeichnung	Description	Dénomination	Descrizione	Benaming	Descripción	PG
1	8 715 503 345 0	Haube hellgrau	Hood light grey	Carpot gris clair	Coperchio grigio chiaro	Deksel lichtgrijs	Capota gris claro	41
2	8 715 401 448 0	Mantel weiß	Front shell white	Habillage blanc	Mantello bianco	Mantel wit	Carcasa blanco	52
3	8 717 208 050 0	Thermometer	Thermometer	Thermomètre	Termometro	Thermometer	Termómetro	31
4	8 714 606 021 0	Klemmfeder	Clamp spring	Ressort	Fermo	KLEEMVEER NTC SK120/140/160-4ZB	Muelle de tecla	25
5	8 714 500 034 0	Sensor WW-NTC mit Aderendhülse 6mm	Temperature sensor 6mm	SONDE DE TEMPERATURE 6mm	Sensore termometrico 6mm	Temperatuurvoeler 6mm	Sensor de temperatura 6mm	34
6	8 711 006 060 0	Stecker	Plug	Connecteur	Spina	STEKKER NTC-VOELER ST...1E/SK 300/ST 75	Anection	16
7	8 709 918 506 0	Anode	Anode	Anode	Anodo	ANODE SO 160-160/1-200-200/1-SK 180-300-	Anodo	43
7	8 709 918 666 0	Anode 1"	Anode 1"	Anode 1"	Anodo 1"	ANODE (KETTING) ST120/160-1E /SK 130-3Z	Anodo 1"	43
8	8 715 503 170 0	Flansch mit Tauchrohr kpl.	Connecting flange	Bride de raccordement	Flangia	FLENS + DICHTING SK - 3ZB	Conjunto brida y junta SK500	40
9	8 710 103 096 0	Dichtungs-Set 100x109D - 115/138Dx3 (1x)	Set of seals 100x109D - 115/138Dx3 (1x)	Jeu de joints 100x109D - 115/138Dx3 (1x)	Set guarnizioni 100x109D - 115/138Dx3	DICHTING FLENS SK...2ZB-3ZB (VANAF 070)	conjunto de juntas 100x109D - 115/138Dx3	23
10	8 715 503 346 0	Abdeckung hellgrau	Covering sheet light grey	Couvercle gris clair	Coperchio grigio chiaro	DEKSEL SK 300-1/400-1/500-1 SOLAR	Chapa de protección girar claro	33
11	2 911 060 291 0	Schraube M10x25 (10x)	Screw M10x25 (10x)	Vis M10x25 (10x)	Vite M10x25 (10x)	Schroef M10x25 (10x)	Tornillo M10x25 (10x)	18
11	2 911 060 342 0	Schraube M12x30 (10x)	Screw M12x30 (10x)	Vis M12x30 (10x)	Vite M12x30 (10x)	Schroef M12x30 (10x)	Tornillo M12x30 (10x)	16
17	8 715 503 239 0	Isolierung	Insulation	Bouchon	Isolamento	ISOLATIE SK 300-1 SOLAR (7719001929)	Aislamiento	23
	8 718 220 038 0	Hülse 1"	Sleeve 1"	Douille 1"	Bocchetta 1"	ISOLATIE DEKSEL SK 300-1/400-1/500-1 SOL	Manguito 1"	09

For:

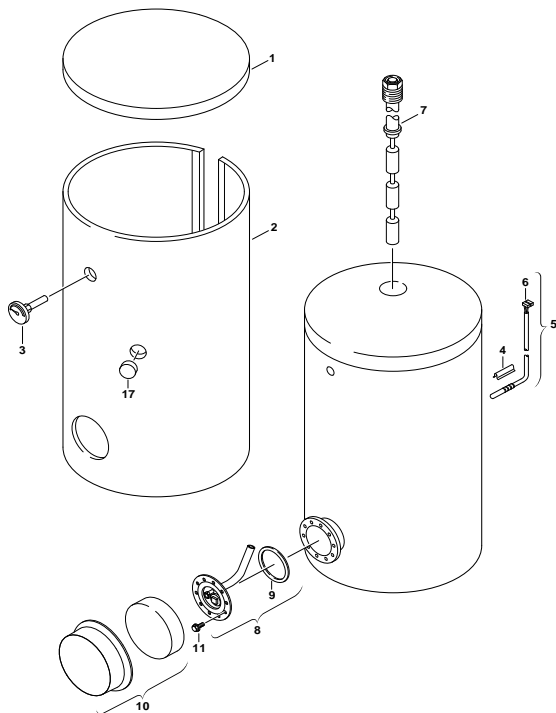

6720901194.AC/G

Pos	Bestell-Nr.	Bezeichnung	Description	Dénomination	Descrizione	Benaming	Descripción	PG
1	8 715 503 420 0	Haube silbergrau	HOOD SILVER GREY	Carpot argent gris	Coperchio argentato grigio	Deksel zilvergrijs	Hood silver grey	41
2	8 715 401 449 0	Mantel silbergrau	Front shell silver grey	Habillage argent gris	Mantello argentato grigio	Mantel zilver grijs	Carcasa plata girar	52
3	8 717 208 050 0	Thermometer	Thermometer	Thermomètre	Termometro	Thermometer	Termómetro	31
4	8 714 606 021 0	Klemmfeder	Clamp spring	Ressort	Fermo	KLEMFVEER NTC SK120/140/160-4ZB	Muelle de tecla	25
5	8 714 500 034 0	Sensor WW-NTC mit Aderendhülse 6mm	Temperature sensor 6mm	SONDE DE TEMPERATURE 6mm	Sensore termometrico 6mm	Temperatuurvoeler 6mm	Sensor de temperatura 6mm	34
6	8 711 006 060 0	Stecker	Plug	Connecteur	Spina	STEKKER NTC-VOELER ST...1E/SK 300ST 75	Anection	16
7	8 709 918 506 0	Anode	Anode	Anode	Anodo	ANODE SO 160-160/1-200-200/1-SK 180-300-	Anodo	43
7	8 709 918 666 0	Anode 1"	Anode 1"	Anode 1"	Anodo 1"	ANODE (KETTING) ST120/160-1E /SK 130-3Z	Anodo 1"	43
8	8 715 503 170 0	Flansch mit Tauchrohr kpl.	Connecting flange	Bride de raccordement	Flangia	FLENS + DICHTING SK - 3ZB	Conjunto brida y junta SK500	40
9	8 710 103 096 0	Dichtungs-Set 100x109D - 115/138Dx3 (1x)	Set of seals 100x109D - 115/138Dx3 (1x)	Jeu de joints 100x109D - 115/138Dx3 (1x)	Set guarnizioni 100x109D - 115/138Dx3	DICHTING FLENS SK...2ZB-3ZB (VANAF 070)	conjunto de juntas 100x109D - 115/138Dx3	23
10	8 715 503 424 0	Abdeckung gelb	Covering sheet yellow	Couvercle jaune	Coperchio giallo	Afdichting geel	Chapa de protección amarillo	33
11	2 911 060 291 0	Schraube M10x25 (10x)	Screw M10x25 (10x)	Vis M10x25 (10x)	Vite M10x25 (10x)	Schroef M10x25 (10x)	Tornillo M10x25 (10x)	18
11	2 911 060 342 0	Schraube M12x30 (10x)	Screw M12x30 (10x)	Vis M12x30 (10x)	Vite M12x30 (10x)	Schroef M12x30 (10x)	Tornillo M12x30 (10x)	16
17	8 715 503 239 0	Isolierung	Insulation	Bouchon	Isolamento	ISOLATIE SK 300-1 SOLAR (7719001929)	Aislamiento	23
	8 718 220 038 0	Hülse 1"	Sleeve 1"	Douille 1"	Bocchetta 1"	ISOLATIE DEKSEL SK 300-1/400-1/500-1 SOL	Manguito 1"	09

For:

Ersatzteilliste  
Spare parts list  
Liste des pièces de rechange  
Lista parti di ricambio  
Onderdelenlijst  
Lista de repuestos

**SK 500-3 ZB - 7719001371**

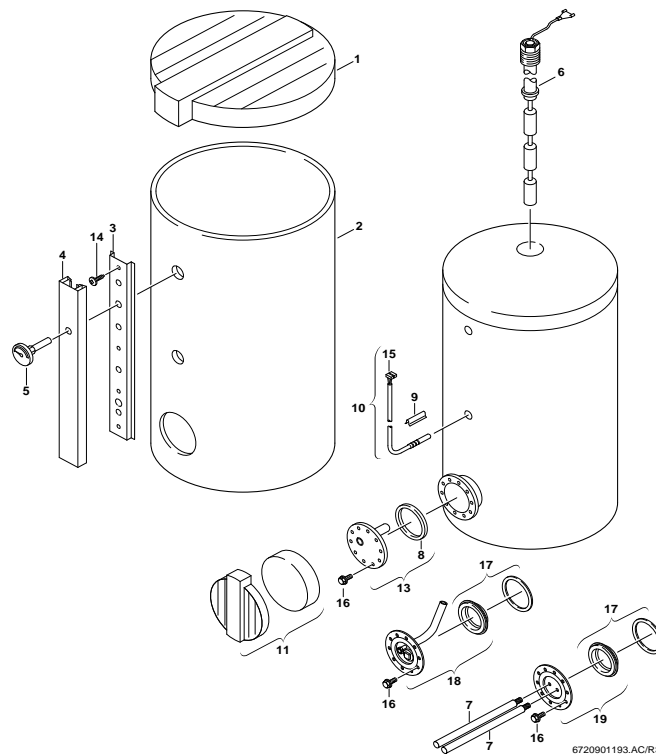

Pos	Bestell-Nr.	Bezeichnung	Description	Dénomination	Descrizione	Benaming	Descripción	PG
1	8 715 503 248 0	Haube grau	Hood grey	Capot gris	Carpot grigio	Deksel grijs	Tapa superior	42
1	8 715 503 437 0	Haube hellgrau	Hood light grey	Carpot gris clair	Coperchio grigio chiaro	Deksel lichtgrijs	Capota girar claro	42
2	8 715 401 304 0	Mantel weiß	Shell white	Habillage blanc	Mantello bianco	Mantel wit	Carcasa blanco	52
3	8 718 005 565 0	Schiene	Bar	Barre	Binario	Strip	rail	34
4	8 715 503 251 0	Abdeckung grau	Covering sheet grey	Couvercle gris	Coperchio grigio	AFDEKPLAAT SK 300-3Z	Tapa	42
4	8 715 503 435 0	Abdeckung hellgrau	Covering sheet light grey	Couvercle gris clair	Coperchio grigio chiaro	Afdichting lichtgrijs	Chapa de protección girar claro	42
5	8 717 208 059 0	Thermometer	Thermometer	Thermomètre	Termometro	THERMOMETER SK 300-3ZB	Termómetro	38
7	8 719 918 981 0	Anode	Anode	Anode	Anodo	Anode	Anodo	43
8	8 710 103 145 0	Dichtring 190/245Dx3	Washer	Joint	Guarnizione	DICHTING FLENS SK 300-3ZB (TOT FD 07/03)	Anillo junta	30
9	8 714 606 021 0	Klemmfeder	Clamp spring	Ressort	Fermo	KLEMVEER NTC SK120/140/160-4ZB	Muelle de tecla	25
10	8 714 500 034 0	Sensor WW-NTC mit Aderendhülse 6m	Temperature sensor 6mm	SONDE DE TEMPERATURE 6mm	Sensore termometrico 6mm	Temperatuurvoeler 6mm	Sensor de temperatura 6mm	34
11	8 715 503 247 0	Abdeckung grau	Covering sheet grey	Couvercle gris	Coperchio grigio	Afdichting grijs	Chapa protección	40
11	8 715 503 436 0	Abdeckung hellgrau	Covering sheet light grey	Couvercle gris clair	Coperchio grigio chiaro	Afdichting lichtgrijs	Chapa de protección girar claro	40
14	8 713 403 008 0	Schraube (10x)	Screw	Vis (10x)	Vite (10x)	Schroef (10x)	Tornillo (10x)	11
15	8 711 006 060 0	Stecker	Plug	Connecteur	Spina	STECKER NTC-VOELER ST...1ESK 300/ST 75	Anection	16
16	2 911 060 291 0	Schraube M10x25 (10x)	Screw M10x25 (10x)	Vis M10x25 (10x)	Vite M10x25 (10x)	Schroef M10x25 (10x)	Tornillo M10x25 (10x)	18
16	2 911 060 342 0	Schraube M12x30 (10x)	Screw M12x30 (10x)	Vis M12x30 (10x)	Vite M12x30 (10x)	Schroef M12x30 (10x)	Tornillo M12x30 (10x)	16
17	8 710 103 096 0	Dichtungs-Set 100x109D - 115/138Dx3 (1x)	Set of seals 100x109D - 115/138Dx3 (1x)	Jeu de joints 100x109D - 115/138Dx3 (1x)	Set guarnizioni 100x109D - 115/138Dx3	DICHTING FLENS SK...2ZB-3ZB (VANA AF 07/0)	conjunto de juntas 100x109D - 115/138Dx3	23
19	8 715 503 526 0	Flansch DN120	Connecting flange	Trappe de visite	Flangia	Aansluitflens	Brida de conexión	38
	8 718 220 039 0	Hülse 1 1/4"	Sleeve 1 1/4"	Douille 1 1/4"	Bocchetta 1 1/4"	Bus 1 1/4"	Manguito 1 1/4"	09

For:

Ersatzteilliste  
 Spare parts list  
 Liste des pièces de rechange  
 Lista parti di ricambio  
 Onderdelenlijst  
 Lista de repuestos

# SK 800 ZB - 7719001676

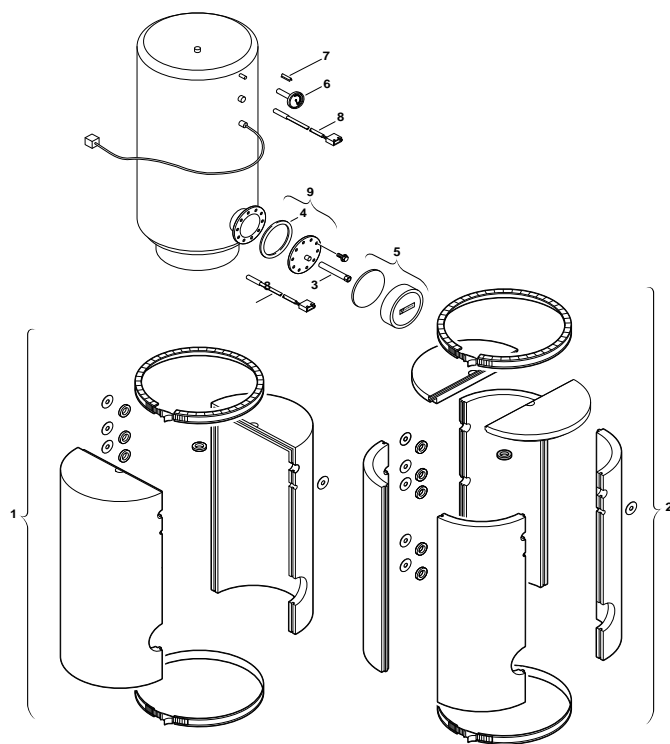

Pos	Bestell-Nr.	Bezeichnung	Description	Dénomination	Descrizione	Benaming	Descripción	PG
1	<b>7 719 001 764</b>	Mantel SK 800-ZB	Outer_case SK 800-ZB	Mantel SK 800-ZB	Mantel SK 800-ZB	Mantel SK 800-ZB	Mantel SK 800-ZB	
3	<b>8 719 928 111 0</b>	Anode	Anode	Anode	Anodo	Anode	Anodo	51
4	<b>8 710 103 519 0</b>	Dichtung	Washer	Joint	Guarnizione	Pakkingring	Junta	35
5	<b>8 718 006 730 0</b>	Abdeckung	Covering sheet	Couvercle	Coperchio	Afdichting	Chapa de protección	38
6	<b>8 717 208 114 0</b>	Thermometer	Thermometer	Thermomètre	Termometro	Thermometer	Termómetro	38
7	<b>8 714 606 024 0</b>	Klemmfeder	Clamp spring	RESSORT POUR THERMOMETRE	Fermo	KLEMVEER V/THERMOMETER ST/SO	Muelle fijación	20
8	<b>8 714 500 034 0</b>	Sensor WW-NTC mit Aderendhülse 6m	Temperature sensor 6mm	SONDE DE TEMPERATURE 6mm	Sensore termometrico 6mm	Temperatuurvoeler 6mm	Sensor de temperatura 6mm	34
9	<b>8 715 503 302 0</b>	Flansch	Connecting flange	Trappe de visite	Flangia	Aansluitflens	Brida de conexión	54

For:

Ersatzteilliste  
 Spare parts list  
 Liste des pièces de rechange  
 Lista parti di ricambio  
 Onderdelenlijst  
 Lista de repuestos

**SK 1000 ZB - 7719001675**

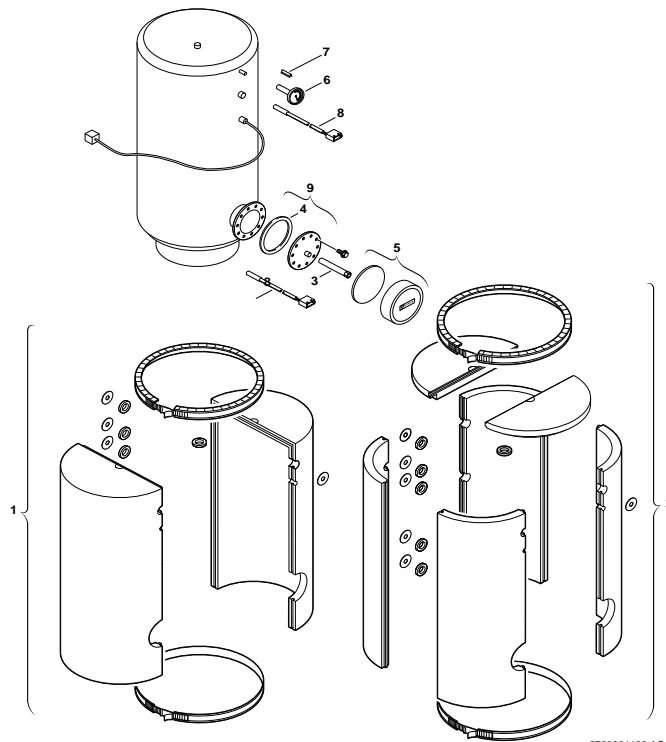

6720901189.AC/G

Pos	Bestell-Nr.	Bezeichnung	Description	Dénomination	Descrizione	Benaming	Descripción	PG
2	<b>7 719 001 766</b>	Mantel SK 1000-ZB	Outer_case SK 1000-ZB	Mantel SK 1000-ZB	Mantel SK 1000-ZB	Mantel SK 1000-ZB	Mantel SK 1000-ZB	
3	<b>8 719 928 111 0</b>	Anode	Anode	Anode	Anodo	Anode	Anodo	51
4	<b>8 710 103 519 0</b>	Dichtung	Washer	Joint	Guarnizione	Pakkingring	Junta	35
5	<b>8 718 006 730 0</b>	Abdeckung	Covering sheet	Couvercle	Coperchio	Afdichting	Chapa de protección	38
6	<b>8 717 208 114 0</b>	Thermometer	Thermometer	Thermomètre	Termometro	Thermometer	Termómetro	38
7	<b>8 714 606 024 0</b>	Klemmfeder	Clamp spring	RESSORT POUR THERMOMETRE	Fermo	KLEMVEER W/THERMOMETER ST/SO	Muelle fijación	20
8	<b>8 714 500 034 0</b>	Sensor WW-NTC mit Aderendhülse 6m	Temperature sensor 6mm	SONDE DE TEMPERATURE 6mm	Sensore termometrico 6mm	Temperatuurvoeler 6mm	Sensor de temperatura 6mm	34
9	<b>8 715 503 302 0</b>	Flansch	Connecting flange	Trappe de visite	Flangia	Aansluitflens	Brida de conexión	54

For:

Ersatzteilliste

Spare parts list

Liste des pièces de rechange

Lista parti di ricambio

Onderdelenlijst

Lista de repuestos

**SK90-2 - 7719000391**

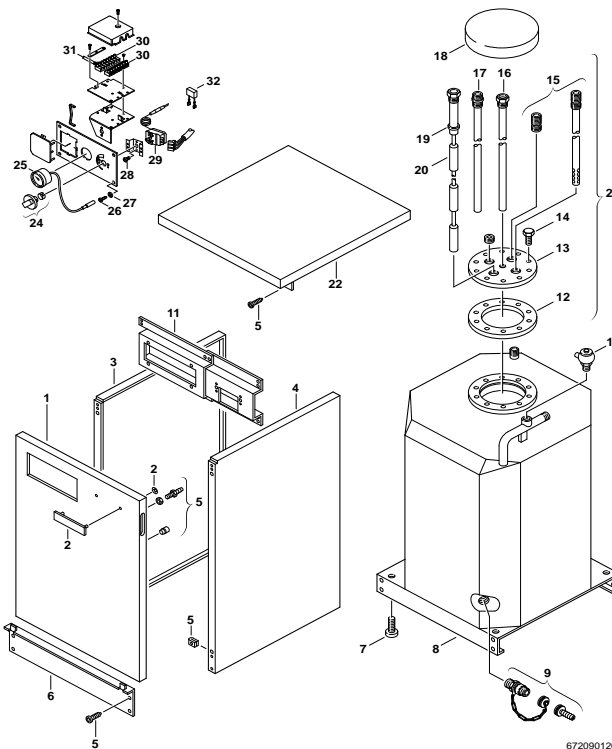

6720901206 AC/G

Pos	Bestell-Nr.	Bezeichnung	Description	Dénomination	Descrizione	Benaming	Descripción	PG
1	8 718 006 390 0	Tür	Door	Porte	Panello frontale	Deur	Puerta	43
2	8 701 103 029 0	Warenzeichen	Trade mark badge	Marquage	Targhetta	Fabrieksmerk	Marca	15
3	8 718 007 182 0	Seitenwand links	Side panel left	Côté gauche	Panello laterale sinistra	Zijpaneel links	Pared lateral a la izquierda	39
4	8 718 007 183 0	Seitenwand rechts	Side panel right	Côté droit	Panello laterale a destra	Zijpaneel rechts	Pared lateral a la derecha	39
5	8 719 918 771 0	Befestigungssatz	Fixing set	Joint de fixation	Set di fissaggio	Bevestigingsset	Juego piezas de fijacion	25
6	8 718 005 174 0	Blende	Shield	Cache	Mascherina	Paneel	Chapa cuadro	26
7	8 713 401 046 0	Stellfuß	Foot	Pied	Vite	Voet	Pie	13
8	8 715 407 122 0	Behälter	Reservoir	Réceptient	Sostegno	Reservoir	Déposito	
9	8 738 505 974 0	Ventil	Globe valve	Robinet	Valvola	AFSLUITKRAAN	Válvula de globo	26
10	8 719 918 314 0	Entlüftungsventil	Vent valve	Dégazeur	Valvola di scarico	Ontluchtventiel	Válvula de purga de aire	16
11	8 718 006 366 0	Traverse	Connection plate	Traverse	Traversa	Vangschaal	Placa de unión	39
12	8 719 918 662 0	Dichtung	Washer	Joint	Guarnizione	DICHTING FLENS SK 130-180/ZZ	Junta	26
13	8 715 503 086 0	Flansch	Connecting flange	Bride de raccordement	Flangia	FLENS SK..-ZZ	Brida de conexión	36
14	2 911 060 342 0	Schraube M12x30 (10x)	Screw M12x30 (10x)	Vis M12x30 (10x)	Vite M12x30 (10x)	Schroef M12x30 (10x)	Tornillo M12x30 (10x)	16
15	8 710 735 438 0	Ein-/Auslaufrohr Edelstahl, 1253mm	Inlet/Outlet tube	Tube d'arrivée/évacuation	Tube della presa/ entrata	Inlet/Outlet tube	Pipa del producto/de salida	41
16	8 710 702 055 0	Tauchhülse	Sensor pocket	Douille	Boccola	Dompelhuls	Casquillo de la caldera	39
17	7 719 001 934	ZL102/1 - Zirkulationsrohr	ZL102/1 - circulation pipe	ZL102/1 - Tube circulation	ZL102/1 - Tubo di ricircolo	ZL102/1 - Circulatiebuis	ZL102/1 - tubo de recirculación	
18	8 718 006 396 0	Isolierung	Insulation	Isolation	Isolamento	Isolatie	Aislamiento	24
19	8 710 103 086 0	Dichtscheibe (10x)	Washer (10x)	Joint (10x)	Guarnizione (10x)	DICHTING ANODE VOOR SO 160	Junta (10x)	22
20	8 709 918 505 0	Anode	Anode	Anode	Anodo	ANODE SO 120-SK 130/ZZ-ST 120	Anodo	39
21	8 715 503 096 0	Flansch	Connecting flange	Trappe de visite	Flangia	Aansluitflens	Brida de conexión	45
22	8 718 006 274 0	Deckel	Cover	Couvercle	Coperchio	Deksel	Tapa	40
24	8 712 000 034 0	Drehknopf	Rotary handle	Bouton de réglage	Manopola	Regelknop	Botón rotativo	12
25	8 737 208 991 0	Thermometer	Thermometer	Thermomètre	Termometro	THERMOMETER SO..-SK..-ZZ-3Z - Z(W).. F	Termómetro	37
26	8 713 403 008 0	Schraube (10x)	Screw	Vis (10x)	Vite (10x)	Schroef (10x)	Tornillo (10x)	11
27	2 916 030 006 0	Sicherungsscheibe (10x)	Retaining ring (10x)	Circlips (10x)	Rondella (10x)	BORGRING UIT TTB 771900055P	Arandela de seguridad (10x)	11

For:

<b>Ersatzteilliste</b> <b>Spare parts list</b> <b>Liste des pièces de rechange</b> <b>Lista parti di ricambio</b> <b>Onderdelenlijst</b> <b>Lista de repuestos</b>	<h1 style="text-align: center;">SK90-2 - 7719000391</h1>
---	--

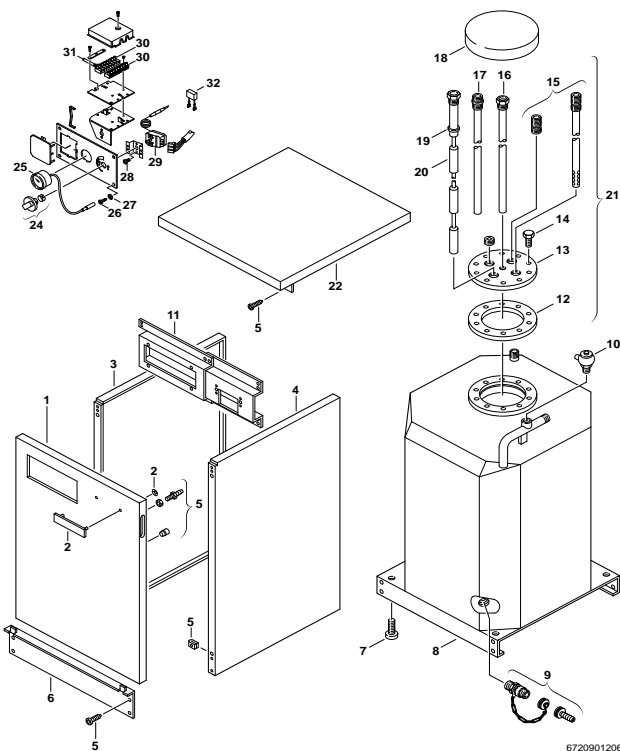

6720901206 AC/G

Pos	Bestell-Nr.	Bezeichnung	Description	Dénomination	Descrizione	Benaming	Descripción	PG
29	8 717 206 186 0	Temperaturregler	Flow thermostat	Thermostat	Thermostat	AQUASTAAT MI WISSELKONTAKT SO 120-160-200	Regulador de temperatura	36
30	8 711 006 046 0	Klemmleiste 24V	Terminal strip 24V	Bornier 24V	Cablaggio 24V	Klemmenstrook 24V	Regleta de bornes 24V	08
31	8 714 401 396 0	Kabel	Cable	Faisceau	Cablaggio	Kabel	Cable	23
32	8 717 301 017 0	Entstörkondensator	ENTSTÖRKONDENSATOR	Condensateur	Condensatore	CONDENSATOR VOOR AQUASTAAT 8 737 206 974	Condensador filtro	14

For:

Ersatzteilliste  
 Spare parts list  
 Liste des pièces de rechange  
 Lista parti di ricambio  
 Onderdelenlijst  
 Lista de repuestos

# SK120-4ZB/C2 - 7719002119

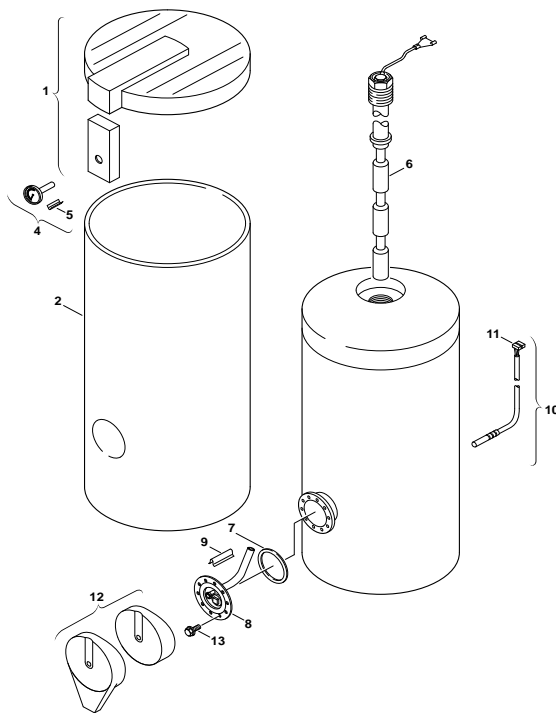

6720901190.AB/G

Pos	Bestell-Nr.	Bezeichnung	Description	Dénomination	Descrizione	Benaming	Descripción	PG
1	8 715 503 417 0	Haube silbergrau	Hood silver grey	Carpot argent gris	Coperchio argentato grigio	Deksel zilvergrijs	Capota plata girar	42
2	8 715 401 387 0	Mantel silbergrau	Front shell silver grey	Habillage argent gris	Mantello argentato grigio	Mantel zilver grijs	Carcasa plata girar	47
4	8 717 208 050 0	Thermometer	Thermometer	Thermomètre	Termometro	Thermometer	Termómetro	31
5	8 714 606 024 0	Klemmfeder	Clamp spring	RESSORT POUR THERMOMETRE	Fermo	KLEMVEER V/THERMOMETER ST/ISO	Muelle fijación	20
6	8 709 918 638 0	Anode 1"	Anode 1"	Anode 1"	Anodo 1"	ANODE SK 120/140/160-4ZB	Anodo 1"	37
7	8 710 103 096 0	Dichtungs-Set 100x109D - 115/138Dx3 (1x)	Set of seals 100x109D - 115/138Dx3 (1x)	Jeu de joints 100x109D - 115/138Dx3 (1x)	Set guarnizioni 100x109D - 115/138Dx3	DICHTING FLENS SK...2ZB-3ZB (VANAF 07/0)	conjunto de juntas 100x109D - 115/138Dx3	23
8	8 715 503 170 0	Flansch mit Tauchrohr kpl.	Connecting flange	Bride de raccordement	Flangia	FLENS + DICHTING SK - 3ZB	Conjunto brida y junta SK500	40
9	8 714 606 021 0	Klemmfeder	Clamp spring	Ressort	Fermo	KLEMVEER NTC SK 120/140/160-4ZB	Muelle de tecla	25
10	8 714 500 034 0	Sensor WW-NTC mit Aderendhülse 6mm	Temperature sensor 6mm	SONDE DE TEMPERATURE 6mm	Sensore termometrico 6mm	Temperatuurvoeler 6mm	Sensor de temperatura 6mm	34
11	8 711 006 060 0	Stecker	Plug	Connecteur	Spina	STEKKER NTC-VOELER ST...1E/SK 300/ST 75	Anection	16
12	8 715 503 422 0	Abdeckung silbergrau	Covering sheet silver grey	Couvercle argent gris	Coperchio argentato grigio	Afdichting zilver grijs	Chapa de protección plata girar	43
13	2 911 060 291 0	Schraube M10x25 (10x)	Screw M10x25 (10x)	Vis M10x25 (10x)	Vite M10x25 (10x)	Schroef M10x25 (10x)	Tornillo M10x25 (10x)	18
13	2 911 060 342 0	Schraube M12x30 (10x)	Screw M12x30 (10x)	Vis M12x30 (10x)	Vite M12x30 (10x)	Schroef M12x30 (10x)	Tornillo M12x30 (10x)	16
	8 710 402 029 0	Kappe	panel	Capot de protection	Tappo	beschermkapje	tapa	20
For:								



Ersatzteilliste  
Spare parts list  
Liste des pièces de rechange  
Lista parti di ricambio  
Onderdelenlijst  
Lista de repuestos

**SK130-1E - 7719001211**

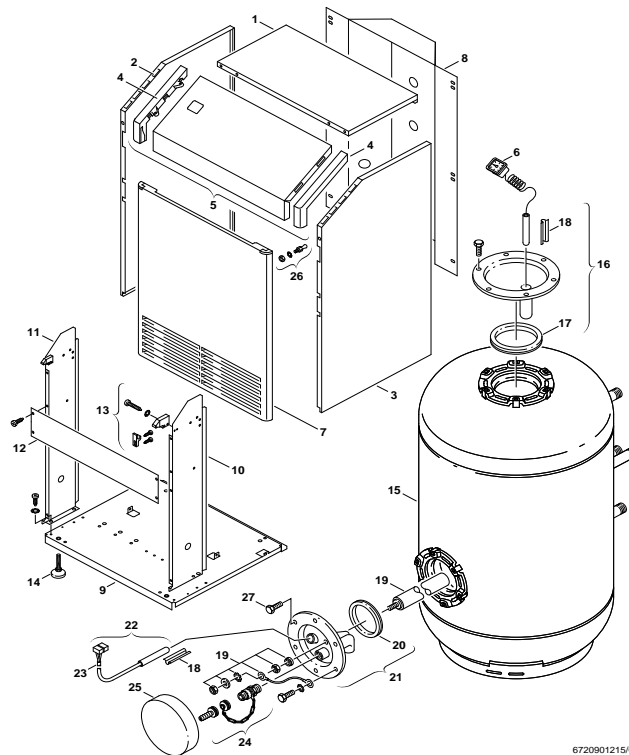

6720901215/G

Pos	Bestell-Nr.	Bezeichnung	Description	Dénomination	Descrizione	Benaming	Descripción	PG
1	8 711 304 664 0	Deckel weiß	Cover white	Couvercle blanc	Coperchio bianco	Deksel wit	Tapa blanco	36
2	8 729 010 650 0	Seitenwand links weiß	Side panel left white	Côté droit blanc	Pannelo laterale sinistra bianco	Zijpaneel links wit	Pared lateral izquierda blanco	38
3	8 729 010 649 0	Seitenwand rechts weiß	Side panel right white	Côté droit blanc	Pannelo laterale a destra bianco	Zijpaneel rechts wit	Pared lateral derecha blanco	38
4	8 729 010 723 0	Abschlußprofil-Satz	Final profile-set	Profil panneau lateral-kit	Final profile-set	Final profile-set	Final profile-set	36
5	8 715 506 246 0	Blende weiß	Screen white	Sachet caches	Mascherina bianco	Paneel wit	Chapa Cuadro blanco	39
6	8 717 208 036 0	Thermometer	Thermometer	Thermomètre	Termometro	THERMOMETER SK...3Z-ST 110-E	Termómetro	37
7	8 729 010 652 0	Tür weiß	Door white	Porte blanc	Pannelo frontale bianco	Deur wit	Puerta blanco	41
8	8 715 402 226 0	Rückwand	Back_panel	Dossieret	Schienale	Achterwand	Respaldo	47
9	8 729 010 647 0	Bodenblech	Oven bottom	Tôle de fond	Lamiera di fondo	Bodemplaat	Chapa de fondo	42
10	8 729 010 042 0	Halblech	Connection plate	Plaque de jonction	Lamierino	Vangschaal	Placa de unión	30
11	8 729 010 043 0	Halblech	Connection plate	Plaque de jonction	Lamierino	Vangschaal	Placa de unión	30
12	8 715 402 227 0	Traverse	Connection plate	Traverse	Traversa	Vangschaal	Placa de unión	32
14	8 713 401 046 0	Stellfuß	Foot	Pied	Vite	Voet	Pie	13
15	8 715 407 213 0	Behälter	Reservoir	Réipient	Sostegno	Reservoir	Déposito	
16	8 715 503 177 0	Flansch	Connecting flange	Bride de raccordement	Flangia	Aansluitflens	Brida de conexión	36
17	8 710 103 513 0	Dichtung	Washer	Joint	Guarnizione	DICHTING ST 75	Junta	20
18	8 711 200 005 0	Klemmfeder	Clamp spring	Ressort	Fermo	Haarspeldveer	Muelle de tecla	13
19	8 729 010 747 0	Anode	Anode	Anode	Anodo	Anode	Anodo	40
20	8 710 103 514 0	Dichtung	Washer	Joint	Guarnizione	Pakkingring	Junta	17
21	8 715 503 178 0	Flansch	Connecting flange	Bride de raccordement	Flangia	Aansluitflens	Brida de conexión	47
22	8 714 500 034 0	Sensor WW-NTC mit Aderendhülse 6mm	Temperature sensor 6mm	SONDE DE TEMPERATURE 6mm	Sensore termometrico 6mm	Temperatuurvoeler 6mm	Sensor de temperatura 6mm	34
23	8 711 006 060 0	Stecker	Plug	Connecteur	Spina	STEKKER NTC-VOELER ST...1E/SK 300/ST 75	Aneccion	16
24	8 738 505 974 0	Ventil	Globe valve	Robinet	Valvola	AFSLUITKRAAN	Válvula de globo	26
25	8 702 303 007 0	Abdeckung	Covering sheet	Couvercle	Coperchio	Afdichting	Chapa de protección	18
26	8 729 010 801 0	Verschlußsatz	Lock set	Sachet de serrure	Coperchio	Afsluitingsset	Conjunto cerradura	22
27	2 911 060 342 0	Schraube M12x30 (10x)	Screw M12x30 (10x)	Vis M12x30 (10x)	Vite M12x30 (10x)	Schroef M12x30 (10x)	Tornillo M12x30 (10x)	16

For:

Ersatzteilliste  
Spare parts list  
Liste des pièces de rechange  
Lista parti di ricambio  
Onderdelenlijst  
Lista de repuestos

# SK130-2R - 7719000394

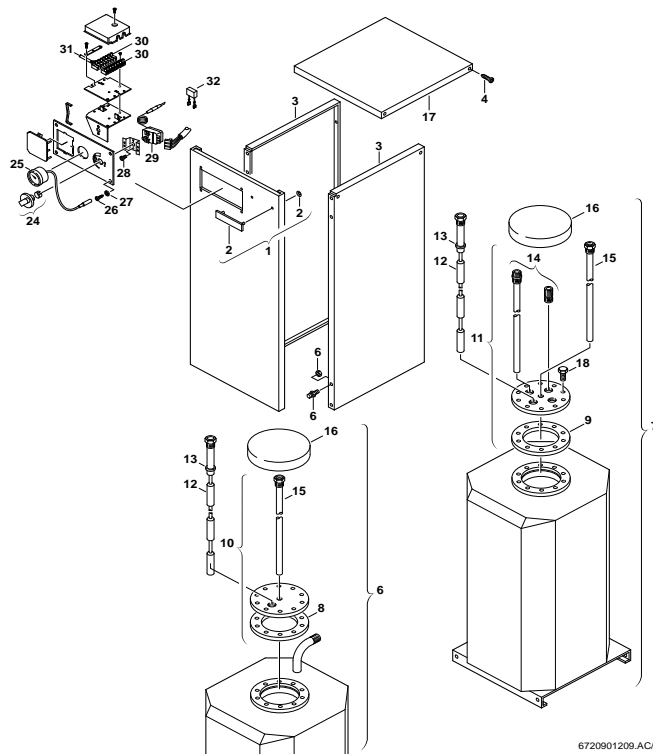

6720901209 AC/G

Pos	Bestell-Nr.	Bezeichnung	Description	Dénomination	Descrizione	Benaming	Descripción	PG
1	8 715 402 104 0	Vorderwand	Cover	Couvercle	Coperchio	Voordeksel	Tapa	48
2	8 701 103 029 0	Warenzeichen	Trade mark badge	Marquage	Targhetta	Fabrieksmerk	Marca	15
3	8 718 007 138 0	Seitenteil	Side panel	Paroi latérale	Panello laterale	Zijpaneel	Lateral costado	45
4	8 719 918 772 0	Befestigungssatz	Fixing set	Joint de fixation	Set di fissaggio	Bevestigingsset	Juego piezas de fijacion	23
6	8 715 407 137 0	Behälter	Reservoir	Réipient	Sostegno	Reservoir	Déposito	78
8	8 710 103 088 0	Dichtung	Washer	Joint	Guarnizione	DICHTING FLENS SK 300-3ZB	Junta	19
9	8 719 918 662 0	Dichtung	Washer	Joint	Guarnizione	DICHTING FLENS SK 130-180/ZZ	Junta	26
10	8 715 503 109 0	Flansch	Connecting flange	Trappe de visite	Flangia	Aansluitflens	Brida de conexión	51
11	8 715 503 096 0	Flansch	Connecting flange	Trappe de visite	Flangia	Aansluitflens	Brida de conexión	45
12	8 709 918 505 0	Anode	Anode	Anode	Anodo	ANODE SO 120-SK 130/2Z-ST 120	Anodo	39
13	8 710 103 086 0	Dichtscheibe (10x)	Washer (10x)	Joint (10x)	Guarnizione (10x)	DICHTING ANODE VOOR SO 160	Junta (10x)	22
14	8 710 735 438 0	Ein-/Auslaufrohr Edelstahl, 1253mm	Inlet/Outlet tube	Tube d'arrivée/évacuation	Tubo della presa/ entrata	Inlet/Outlet tube	Pipa del producto/de salida	41
15	8 710 702 055 0	Tauchhülse	Sensor pocket	Douille	Boccola	Dompelhuls	Casquillo de la caldera	39
16	8 718 006 397 0	Isolierung	Insulation	Isolation	Isolamento	Isolatie	Aislamiento	23
17	8 718 005 175 0	Deckel weiß	Cover white	Couvercle blanc	Coperchio bianco	Deksel wit	Tapa blanco	42
18	2 911 060 342 0	Schraube M12x30 (10x)	Screw M12x30 (10x)	Vis M12x30 (10x)	Vite M12x30 (10x)	Schroef M12x30 (10x)	Tornillo M12x30 (10x)	16
24	8 712 000 034 0	Drehknopf	Rotary handle	Bouton de réglage	Manopola	Regelknop	Botón rotativo	12
25	8 737 208 991 0	Thermometer	Thermometer	Thermomètre	Termometro	THERMOMETER SO...SK...ZZ-3Z - Z(W)...F	Termómetro	37
26	8 713 403 008 0	Schraube (10x)	Screw	Vis (10x)	Vite (10x)	Schroef (10x)	Tornillo (10x)	11
27	2 916 030 006 0	Sicherungsscheibe (10x)	Retaining ring (10x)	Circlips (10x)	Rondella (10x)	BORGRING UIT TTB 771900055P	Arandela de seguridad (10x)	11
29	8 717 206 186 0	Temperaturregler	Flow thermostat	Thermostat	Thermostat	AQUASTAAT M/WISSELKONTAKT SO 120-160-200	Regulador de temperatura	36
30	8 711 006 046 0	Klemmleiste 24V	Terminal strip 24V	Bornier 24V	Cablaggio 24V	Klemmenstrook 24V	Regleta de bornes 24V	08
31	8 714 401 396 0	Kabel	Cable	Faisceau	Cablaggio	Kabel	Cable	23
32	8 717 301 017 0	Entstörkondensator	ENTSTÖRKONDENSATOR	Condensateur	Condensatore	CONDENSATOR VOOR AQUASTAAT 8 737 206 974	Condensador filtro	14

For:

Ersatzteilliste  
Spare parts list  
Liste des pièces de rechange  
Lista parti di ricambio  
Onderdelenlijst  
Lista de repuestos

# SK130-2W - 7719000392

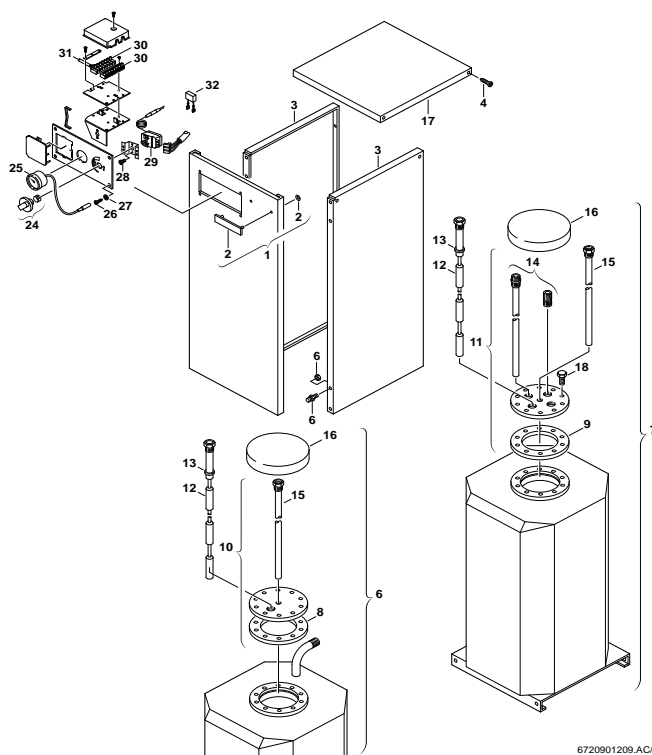

Pos	Bestell-Nr.	Bezeichnung	Description	Dénomination	Descrizione	Benaming	Descripción	PG
1	8 715 402 104 0	Vorderwand	Cover	Couvercle	Coperchio	Voordeksel	Tapa	48
2	8 701 103 029 0	Warenzeichen	Trade mark badge	Marquage	Targhetta	Fabrieksmerk	Marca	15
3	8 718 007 138 0	Seitenteil	Side panel	Paroi latérale	Pannelo laterale	Zijpaneel	Lateral costado	45
4	8 719 918 772 0	Befestigungssatz	Fixing set	Joint de fixation	Set di fissaggio	Bevestigingsset	Juego piezas de fijacion	23
6	8 715 407 137 0	Behälter	Reservoir	Réipient	Sostegno	Reservoir	Déposito	78
8	8 710 103 088 0	Dichtung	Washer	Joint	Guarnizione	DICHTING FLENS SK 300-3ZB	Junta	19
9	8 719 918 662 0	Dichtung	Washer	Joint	Guarnizione	DICHTING FLENS SK 130-180/ZZ	Junta	26
10	8 715 503 109 0	Flansch	Connecting flange	Trappe de visite	Flangia	Aansluitflens	Brida de conexión	51
11	8 715 503 096 0	Flansch	Connecting flange	Trappe de visite	Flangia	Aansluitflens	Brida de conexión	45
12	8 709 918 505 0	Anode	Anode	Anode	Anodo	ANODE SO 120-SK 130/2Z-ST 120	Anodo	39
13	8 710 103 086 0	Dichtscheibe (10x)	Washer (10x)	Joint (10x)	Guarnizione (10x)	DICHTING ANODE VOOR SO 160	Junta (10x)	22
14	8 710 735 438 0	Ein-/Auslaufrohr Edelstahl, 1253mm	Inlet/Outlet tube	Tube d'arrivée/évacuation	Tubo della presa/ entrata	Inlet/Outlet tube	Pipa del producto/de salida	41
15	8 710 702 055 0	Tauchhülse	Sensor pocket	Douille	Boccola	Dompelhuls	Casquillo de la caldera	39
16	8 718 006 397 0	Isolierung	Insulation	Isolation	Isolamento	Isolatie	Aislamiento	23
17	8 718 005 175 0	Deckel weiß	Cover white	Couvercle blanc	Coperchio bianco	Deksel wit	Tapa blanco	42
18	2 911 060 342 0	Schraube M12x30 (10x)	Screw M12x30 (10x)	Vis M12x30 (10x)	Vite M12x30 (10x)	Schroef M12x30 (10x)	Tornillo M12x30 (10x)	16
24	8 712 000 034 0	Drehknopf	Rotary handle	Bouton de réglage	Manopola	Regelknop	Botón rotativo	12
25	8 737 208 991 0	Thermometer	Thermometer	Thermomètre	Termometro	THERMOMETER SO...SK...ZZ-3Z - Z(W)... F	Termómetro	37
26	8 713 403 008 0	Schraube (10x)	Screw	Vis (10x)	Vite (10x)	Schroef (10x)	Tornillo (10x)	11
27	2 916 030 006 0	Sicherungsscheibe (10x)	Retaining ring (10x)	Circlips (10x)	Rondella (10x)	BORGRING UIT TTB 771900055P	Arandela de seguridad (10x)	11
29	8 717 206 186 0	Temperaturregler	Flow thermostat	Thermostat	Thermostat	AQUASTAAT M/WISSELKONTAKT SO 120-160-200	Regulador de temperatura	36
30	8 711 006 046 0	Klemmleiste 24V	Terminal strip 24V	Bornier 24V	Cablaggio 24V	Klemmenstrook 24V	Regleta de bornes 24V	08
31	8 714 401 396 0	Kabel	Cable	Faisceau	Cablaggio	Kabel	Cable	23
32	8 717 301 017 0	Entstörkondensator	ENTSTÖRKONDENSATOR	Condensateur	Condensatore	CONDENSATOR VOOR AQUASTAAT 8 737 206 974	Condensador filtro	14

For:

Ersatzteilliste  
Spare parts list  
Liste des pièces de rechange  
Lista parti di ricambio  
Onderdelenlijst  
Lista de repuestos

**SK130-2Z - 7719000646**

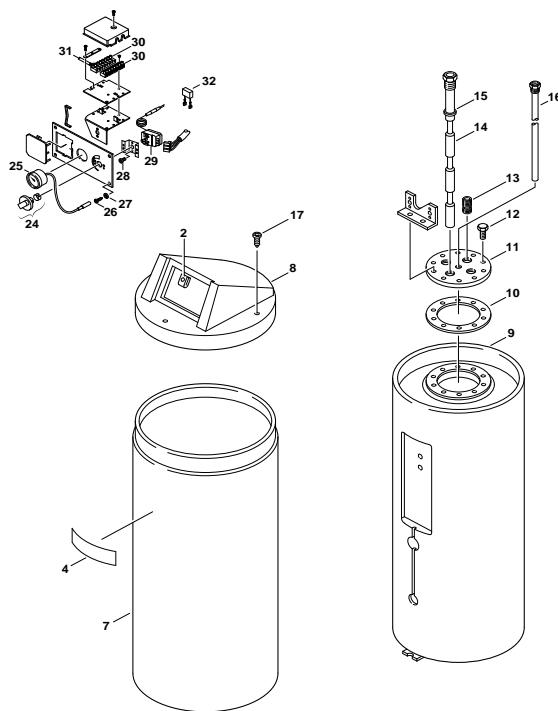

6720901208 AC/G

Pos	Bestell-Nr.	Bezeichnung	Description	Dénomination	Descrizione	Benaming	Descripción	PG
2	8 713 309 026 0	Mutter (10x)	Nut	Ecrou (10x)	Dado (10x)	Moer (10x)	Tuerca (10x)	12
7	8 715 401 106 0	Mantel	Front shell	Habillage	Mantello	Mantel	Carcasa	48
8	8 718 006 436 0	Haube	Hood	Capot	Carpot	Deksel	Capota	39
9	8 715 407 037 0	Behälter	Reservoir	Récipient	Sostegno	Reservoir	Déposito	78
10	8 719 918 662 0	Dichtung	Washer	Joint	Guarnizione	DICHTING FLENS SK 130-180/2Z	Junta	26
11	8 715 503 086 0	Flansch	Connecting flange	Bride de raccordement	Flangia	FLENS SK..-2Z	Brida de conexión	36
12	2 911 060 342 0	Schraube M12x30 (10x)	Screw M12x30 (10x)	Vis M12x30 (10x)	Vite M12x30 (10x)	Schroef M12x30 (10x)	Tornillo M12x30 (10x)	16
13	8 710 735 438 0	Ein-/Auslaufrohr Edelstahl, 1253mm	Inlet/Outlet tube	Tube d'arrivée/évacuation	Tube della presa/ entrata	Inlet/Outlet tube	Pipa del producto/de salida	41
14	8 709 918 505 0	Anode	Anode	Anode	Anodo	ANODE SO 120-SK 130/2Z-ST 120	Anodo	39
15	8 710 103 086 0	Dichtscheibe (10x)	Washer (10x)	Joint (10x)	Guarnizione (10x)	DICHTING ANODE VOOR SO 160	Junta (10x)	22
16	8 710 702 055 0	Tauchhülse	Sensor pocket	Douille	Boccola	Dompelhuls	Casquillo de la caldera	39
17	8 713 403 008 0	Schraube (10x)	Screw	Vis (10x)	Vite (10x)	Schroef (10x)	Tornillo (10x)	11
24	8 712 000 034 0	Drehknopf	Rotary handle	Bouton de réglage	Manopola	Regelknop	Botón rotativo	12
25	8 737 208 991 0	Thermometer	Thermometer	Thermomètre	Termometro	THERMOMETER SO...SK...2Z-3Z - Z(W)...F	Termómetro	37
26	8 713 403 008 0	Schraube (10x)	Screw	Vis (10x)	Vite (10x)	Schroef (10x)	Tornillo (10x)	11
27	2 916 030 006 0	Sicherungsscheibe (10x)	Retaining ring (10x)	Circlips (10x)	Rondella (10x)	BORGRING UIT TTB 771900055P	Arandela de seguridad (10x)	11
29	8 717 206 186 0	Temperaturregler	Flow thermostat	Thermostat	Thermostat	AQUASTAAT MWISSELKONTAKT SO 120-160-200	Regulador de temperatura	36
30	8 711 006 046 0	Klemmleiste 24V	Terminal strip 24V	Bornier 24V	Cablaggio 24V	Klemmenstrook 24V	Regleta de bornes 24V	08
31	8 714 401 396 0	Kabel	Cable	Faisceau	Cablaggio	Kabel	Cable	23
32	8 717 301 017 0	Entstörkondensator	ENTSTÖRKONDENSATOR	Condensateur	Condensatore	CONDENSATOR VOOR AQUASTAAT 8 737 206 974	Condensador filtro	14

For:

Ersatzteilliste

Spare parts list

Liste des pièces de rechange

Lista parti di ricambio

Onderdelenlijst

Lista de repuestos

**SK130-2ZB - 7719000786**

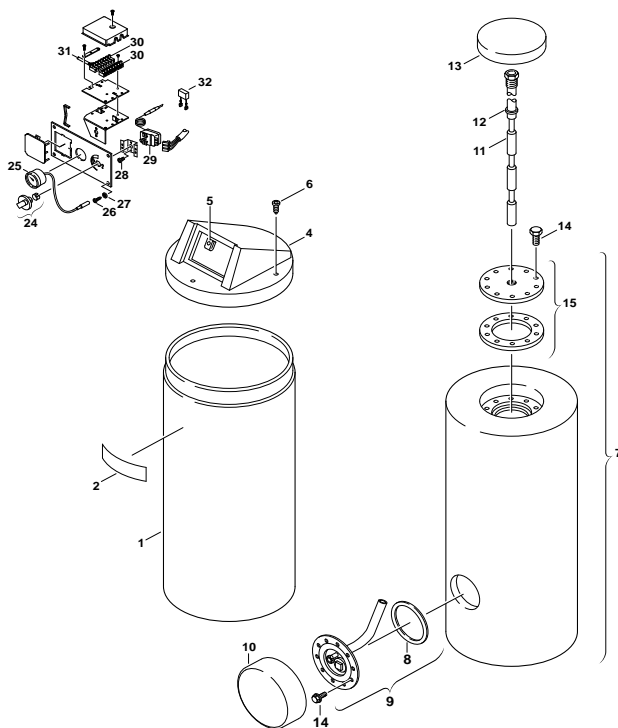

6720901210.AC/G

Pos	Bestell-Nr.	Bezeichnung	Description	Dénomination	Descrizione	Benaming	Descripción	PG
1	8 715 401 127 0	Mantel	Front shell	Habillage	Mantello	Mantel	Carcasa	47
4	8 718 006 436 0	Haube	Hood	Capot	Carpot	Deksel	Capota	39
5	8 713 309 026 0	Mutter (10x)	Nut	Ecrou (10x)	Dado (10x)	Moer (10x)	Tuerca (10x)	12
6	8 713 403 008 0	Schraube (10x)	Screw	Vis (10x)	Vite (10x)	Schroef (10x)	Tornillo (10x)	11
7	8 715 407 162 0	Behälter	Reservoir	Réciptent	Sostegno	Reservoir	Déposito	77
8	8 710 103 096 0	Dichtungs-Set 100x109D - 115/138Dx3 (1x)	Set of seals 100x109D - 115/138Dx3 (1x)	Jeu de joints 100x109D - 115/138Dx3 (1x)	Set guarnizioni 100x109D - 115/138Dx3	DICHTING FLENS SK...2ZB-3ZB (VANAF 070)	conjunto de juntas 100x109D - 115/138Dx3	23
9	8 715 503 170 0	Flansch mit Tauchrohr kpl.	Connecting flange	Bride de raccordement	Flangia	FLENS + DICHTING SK - 3ZB	Conjunto brida y junta SK500	40
10	8 718 006 541 0	Abdeckung	Covering sheet	Couvercle	Coperchio	Afdichting	Chapa de protección	22
11	8 709 918 505 0	Anode	Anode	Anode	Anodo	ANODE SO 120-SK 130/2Z-ST 120	Anodo	39
12	8 710 103 086 0	Dichtscheibe (10x)	Washer (10x)	Joint (10x)	Guarnizione (10x)	DICHTING ANODE VOOR SO 160	Junta (10x)	22
13	8 718 006 397 0	Isolierung	Insulation	Isolation	Isolamento	Isolatie	Aislamiento	23
14	2 911 060 342 0	Schraube M12x30 (10x)	Screw M12x30 (10x)	Vis M12x30 (10x)	Vite M12x30 (10x)	Schroef M12x30 (10x)	Tornillo M12x30 (10x)	16
24	8 712 000 034 0	Drehknopf	Rotary handle	Bouton de réglage	Manopola	Regelknop	Botón rotativo	12
25	8 737 208 991 0	Thermometer	Thermometer	Thermomètre	Termometro	THERMOMETER SO...2Z-3Z - Z(W)...F	Termómetro	37
26	8 713 403 008 0	Schraube (10x)	Screw	Vis (10x)	Vite (10x)	Schroef (10x)	Tornillo (10x)	11
27	2 916 030 006 0	Sicherungsscheibe (10x)	Retaining ring (10x)	Circlips (10x)	Rondella (10x)	BORGRING UIT TTB 771900055P	Arandela de seguridad (10x)	11
29	8 717 206 186 0	Temperaturregler	Flow thermostat	Thermostat	Thermostat	AQUASTAAT MWISSELKONTAKT SO 120-160-200	Regulador de temperatura	36
30	8 711 006 046 0	Klemmleiste 24V	Terminal strip 24V	Bornier 24V	Cablaggio 24V	Klemmenstrook 24V	Regleta de bornes 24V	08
31	8 714 401 396 0	Kabel	Cable	Faisceau	Cablaggio	Kabel	Cable	23
32	8 717 301 017 0	Entstörkondensator	ENTSTÖRKONDENSATOR	Condensateur	Condensatore	CONDENSATOR VOOR AQUASTAAT 8 737 206 974	Condensador filtro	14

For:

**Ersatzteilliste**

Spare parts list

Liste des pièces de rechange

Lista parti di ricambio

Onderdelenlijst

Lista de repuestos

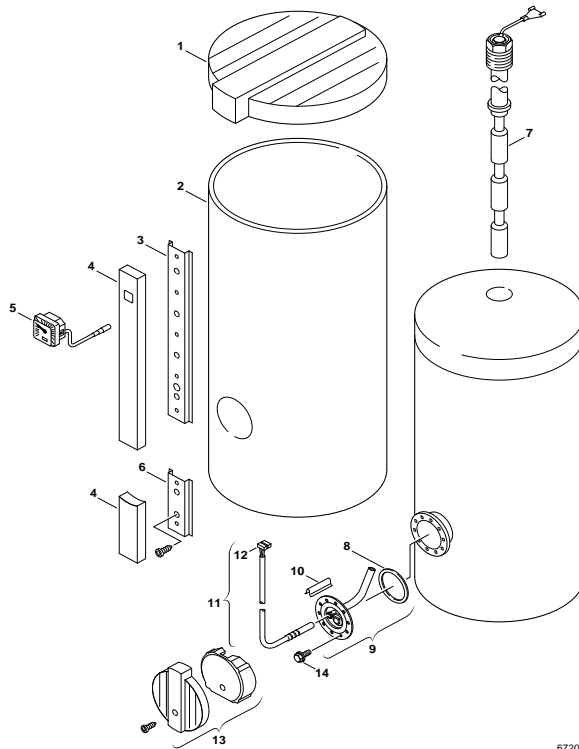
**SK130-3ZB - 7719000958**

6720901213.AB/G

Pos	Bestell-Nr.	Bezeichnung	Description	Dénomination	Descrizione	Benaming	Descripción	PG
1	8 715 503 162 0	Haube	Hood	Capot	Carpot	BOVENDEKSEL SK 180-3Z	Capota	40
2	8 705 411 192 0	Mantel	Front shell	Habillage	Mantello		Carcasa	50
2	8 715 401 245 0	Mantel	Outer_case	Habillage	Mantello	Outer_case	Carcasa	50
3	8 718 005 455 0	Schiene	Frame	Structure	Telaio	Frame	Respaldo	31
4	8 715 503 166 0	Abdeckung	Cover	Couvercle	Coperchio	Afdichting	Chapa de protección	40
5	8 717 208 036 0	Thermometer	Thermometer	Thermomètre	Termometro	THERMOMETER SK...3Z-ST 110-E	Termómetro	37
6	8 718 005 438 0	Schiene	Bar	Barre	Telaio	Strip	Respaldo	28
7	8 709 918 666 0	Anode 1"	Anode 1"	Anode 1"	Anodo 1"	ANODE (KETTING) ST120/160-1E /SK 130-3Z	Anodo 1"	43
8	8 710 103 096 0	Dichtungs-Set 100x109D - 115/138Dx3 (1x)	Set of seals 100x109D - 115/138Dx3 (1x)	Jeu de joints 100x109D - 115/138Dx3 (1x)	Set guarnizioni 100x109D - 115/138Dx3	DICHTING FLENS SK...ZZB-3ZB (VANAF 070)	conjunto de juntas 100x109D - 115/138Dx3	23
9	8 715 503 170 0	Flansch mit Tauchrohr kpl.	Connecting flange	Bride de raccordement	Flangia	FLENS + DICHTING SK - 3ZB	Conjunto brida y junta SK500	40
10	8 714 606 021 0	Klemmfeder	Clamp spring	Ressort	Fermo	KLEIMVEER NTC SK120/140/160-4ZB	Muelle de tecla	25
11	8 714 500 034 0	Sensor WW-NTC mit Aderendhülse 6m	Temperature sensor 6mm	SONDE DE TEMPERATURE 6mm	Sensore termometrico 6mm	Temperatuurvoeler 6mm	Sensor de temperatura 6mm	34
12	8 711 006 060 0	Stecker	Plug	Connecteur	Spina	STEKKER NTC-VOELER ST...1E/SK 300/ST 75	Anection	16
13	8 715 503 163 0	Abdeckung	Cover	Couvercle	Coperchio	Afdichting	Chapa de protección	35
14	2 911 060 342 0	Schraube M12x30 (10x)	Screw M12x30 (10x)	Vis M12x30 (10x)	Vite M12x30 (10x)	Schroef M12x30 (10x)	Tornillo M12x30 (10x)	16
	7 719 001 172	SE8 Schalteinsatz	SE8 switch insert	SE8 Insert de commutation	SE8 Frutto	INZETSTUK	SE-8 MODULO CONTROL SO...1	

For:

Ersatzteilliste  
 Spare parts list  
 Liste des pièces de rechange  
 Lista parti di ricambio  
 Onderdelenlijst  
 Lista de repuestos

SK130-3ZBS3500 - 7719001460

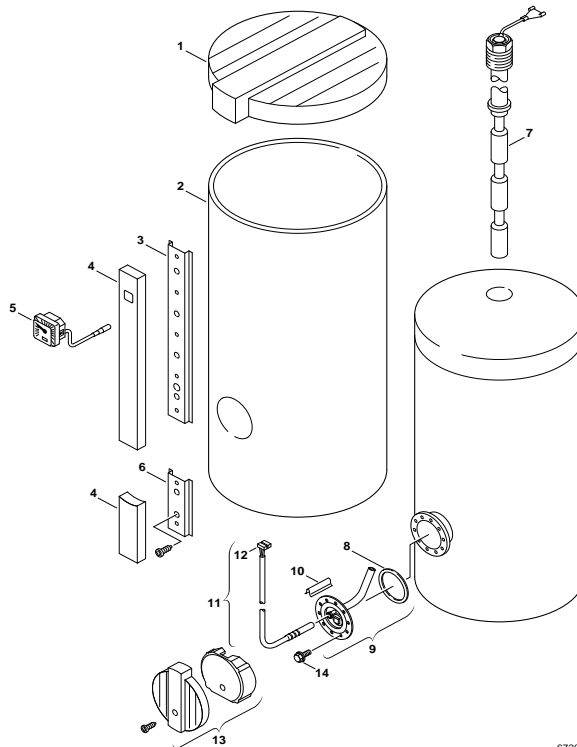

6720901213.AB/G

Pos	Bestell-Nr.	Bezeichnung	Description	Dénomination	Descrizione	Benaming	Descripción	PG
1	8 715 503 162 0	Haube	Hood	Capot	Carpot	BOVENDEKSEL SK 180-3Z	Capota	40
2	8 705 411 192 0	Mantel	Front shell	Habillage	Mantello		Carcasa	50
2	8 715 401 245 0	Mantel	Outer_case	Habillage	Mantello		Carcasa	50
3	8 718 005 455 0	Schiene	Frame	Structure	Telaio		Respaldo	31
4	8 715 503 166 0	Abdeckung	Cover	Couvercle	Coperchio		Chapa de protección	40
5	8 717 208 036 0	Thermometer	Thermometer	Thermomètre	Termometro	THERMOMETER SK...3Z-ST 110-E	Termómetro	37
6	8 718 005 438 0	Schiene	Bar	Barre	Telaio		Respaldo	28
7	8 709 918 666 0	Anode 1"	Anode 1"	Anode 1"	Anodo 1"	ANODE (KETTING) ST120/160-1E /SK 130-3Z	Anodo 1"	43
8	8 710 103 096 0	Dichtungs-Set 100x109D - 115/138Dx3 (1x)	Set of seals 100x109D - 115/138Dx3 (1x)	Jeu de joints 100x109D - 115/138Dx3 (1x)	Set guarnizioni 100x109D - 115/138Dx3	DICHTING FLENS SK...2ZB (VANAF 070)	conjunto de juntas 100x109D - 115/138Dx3	23
9	8 715 503 170 0	Flansch mit Tauchrohr kpl.	Connecting flange	Bride de raccordement	Flangia	FLENS + DICHTING SK - 3ZB	Conjunto brida y junta SK500	40
10	8 714 606 021 0	Klemmfeder	Clamp spring	Ressort	Fermo	KLEIMVEER NTC SK120/140/160-4ZB	Muelle de tecla	25
11	8 714 500 034 0	Sensor WW-NTC mit Aderendhülse 6m	Temperature sensor 6mm	SONDE DE TEMPERATURE 6mm	Sensore termometrico 6mm	Temperatuurvoeler 6mm	Sensor de temperatura 6mm	34
12	8 711 006 060 0	Stecker	Plug	Connecteur	Spina	STEKKER NTC-VOELER ST...1E/SK 300/ST 75	Anection	16
13	8 715 503 163 0	Abdeckung	Cover	Couvercle	Coperchio		Chapa de protección	35
14	2 911 060 342 0	Schraube M12x30 (10x)	Screw M12x30 (10x)	Vis M12x30 (10x)	Vite M12x30 (10x)	Schroef M12x30 (10x)	Tornillo M12x30 (10x)	16
	7 719 001 172	SE8 Schalteinsatz	SE8 switch insert	SE8 Insert de commutation	SE8 Frutto	INZETSTUK	SE-8 MODULO CONTROL SO...1	

For:

Ersatzteilliste  
Spare parts list  
Liste des pièces de rechange  
Lista parti di ricambio  
Onderdelenlijst  
Lista de repuestos

**SK130E - 7719000991**

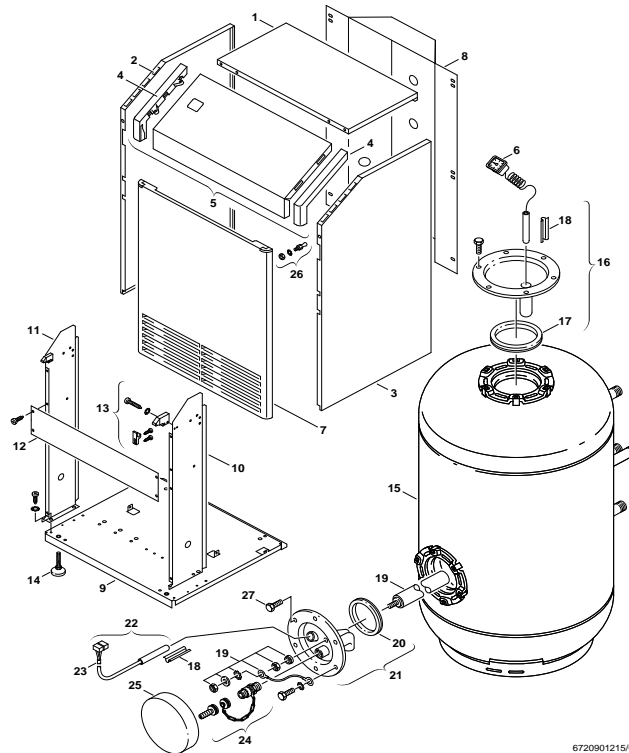

6720901215/G

Pos	Bestell-Nr.	Bezeichnung	Description	Dénomination	Descrizione	Benaming	Descripción	PG
1	8 711 304 664 0	Deckel weiß	Cover white	Couvercle blanc	Coperchio bianco	Deksel wit	Tapa blanco	36
2	8 729 010 650 0	Seitenwand links weiß	Side panel left white	Côté droit blanc	Pannelo laterale sinistra bianco	Zijpaneel links wit	Pared lateral izquierda blanco	38
3	8 729 010 649 0	Seitenwand rechts weiß	Side panel right white	Côté droit blanc	Pannelo laterale a destra bianco	Zijpaneel rechts wit	Pared lateral derecha blanco	38
4	8 729 010 723 0	Abschlußprofil-Satz	Final profile-set	Profil panneau lateral-kit	Final profile-set	Final profile-set	Final profile-set	36
5	8 715 506 246 0	Blende weiß	Screen white	Sachet caches	Mascherina bianco	Paneel wit	Chapa Cuadro blanco	39
6	8 717 208 036 0	Thermometer	Thermometer	Thermomètre	Termometro	THERMOMETER SK...3Z-ST 110-E	Termómetro	37
7	8 729 010 652 0	Tür weiß	Door white	Porte blanc	Pannelo frontale bianco	Deur wit	Puerta blanco	41
8	8 715 402 226 0	Rückwand	Back_panel	Dossieret	Schienale	Achterwand	Respaldo	47
9	8 729 010 647 0	Bodenblech	Oven bottom	Tôle de fond	Lamiera di fondo	Bodemplaat	Chapa de fondo	42
10	8 729 010 042 0	Halblech	Connection plate	Plaque de jonction	Lamierino	Vangschaal	Placa de unión	30
11	8 729 010 043 0	Halblech	Connection plate	Plaque de jonction	Lamierino	Vangschaal	Placa de unión	30
12	8 715 402 227 0	Traverse	Connection plate	Traverse	Traversa	Vangschaal	Placa de unión	32
13	8 729 010 784 0	Verschlusssatz	Lock set	Sachet de serrure	Coperchio	Afsluitingsset	Conjunto cerradura	20
14	8 713 401 046 0	Stellfuß	Foot	Pied	Vite	Voet	Pie	13
15	8 715 407 213 0	Behälter	Reservoir	Réipient	Sostegno	Reservoir	Déposito	
16	8 715 503 177 0	Flansch	Connecting flange	Bride de raccordement	Flangia	Aansluitflens	Brida de conexión	36
17	8 710 103 513 0	Dichtung	Washer	Joint	Guarnizione	DICHTING ST 75	Junta	20
18	8 711 200 005 0	Klemmfeder	Clamp spring	Ressort	Fermo	Haarspeldveer	Muelle de tecla	13
19	8 729 010 747 0	Anode	Anode	Anode	Anodo	Anode	Anodo	40
20	8 710 103 514 0	Dichtung	Washer	Joint	Guarnizione	Pakkingring	Junta	17
21	8 715 503 178 0	Flansch	Connecting flange	Bride de raccordement	Flangia	Aansluitflens	Brida de conexión	47
22	8 714 500 034 0	Sensor WW-NTC mit Aderendhülse 6m	Temperature sensor 6mm	SONDE DE TEMPERATURE 6mm	Sensore termometrico 6mm	Temperatuurvoeler 6mm	Sensor de temperatura 6mm	34
23	8 711 006 060 0	Stecker	Plug	Connecteur	Spina	STECKER NTC-VOELER ST...1E(SK 300)ST 75	Anection	16
24	8 738 505 974 0	Ventil	Globe valve	Robinet	Valvola	AFSLUITKRAAN	Válvula de globo	26
25	8 702 303 007 0	Abdeckung	Covering sheet	Couvercle	Coperchio	Afdichting	Chapa de protección	18
27	2 911 060 342 0	Schraube M12x30 (10x)	Screw M12x30 (10x)	Vis M12x30 (10x)	Vite M12x30 (10x)	Schroef M12x30 (10x)	Tornillo M12x30 (10x)	16

For:



Ersatzteilliste  
Spare parts list  
Liste des pièces de rechange  
Lista parti di ricambio  
Onderdelenlijst  
Lista de repuestos

**SK160-4ZB/C2 - 7719002120**

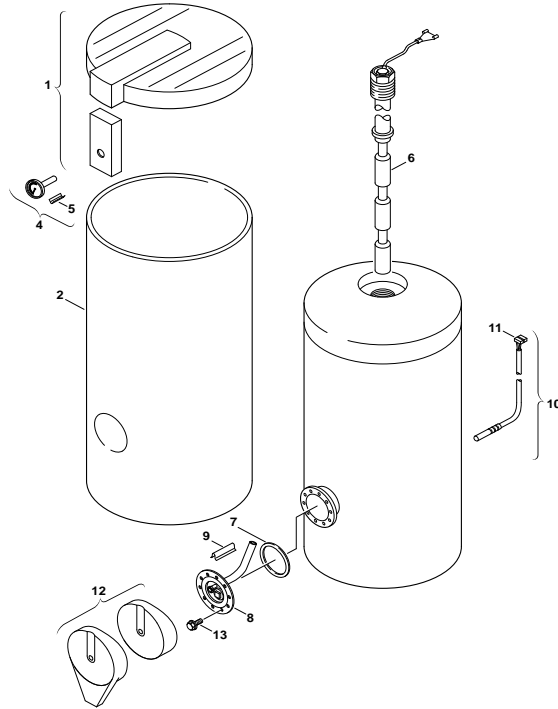

6720901190.AB/G

Pos	Bestell-Nr.	Bezeichnung	Description	Dénomination	Descrizione	Benaming	Descripción	PG
1	<b>8 715 503 417 0</b>	Haube silbergrau	Hood silver grey	Carpot argent gris	Coperchio argentato grigio	Deksel zilvergrijs	Capota plata girar	42
2	<b>8 715 401 395 0</b>	Mantel silbergrau	Front shell silver grey	Habillage argent gris	Mantello argentato grigio	Mantel zilver grijs	Carcasa plata girar	47
4	<b>8 717 208 050 0</b>	Thermometer	Thermometer	Thermomètre	Termometro	Thermometer	Termómetro	31
5	<b>8 714 606 024 0</b>	Klemmfeder	Clamp spring	RESSORT POUR THERMOMETRE	Fermo	KLEMVEER V/THERMOMETER ST/ISO	Muelle fijación	20
6	<b>8 709 918 638 0</b>	Anode 1"	Anode 1"	Anode 1"	Anodo 1"	ANODE SK 120/140/160-4ZB	Anodo 1"	37
7	<b>8 710 103 096 0</b>	Dichtungs-Set 100x109D - 115/138Dx3 (1x)	Set of seals 100x109D - 115/138Dx3 (1x)	Jeu de joints 100x109D - 115/138Dx3 (1x)	Set guarnizioni 100x109D - 115/138Dx3	DICHTING FLENS SK...2ZB-3ZB (VANA F 07/0)	conjunto de juntas 100x109D - 115/138Dx3	23
8	<b>8 715 503 170 0</b>	Flansch mit Tauchrohr kpl.	Connecting flange	Bride de raccordement	Flangia	FLENS + DICHTING SK - 3ZB	Conjunto brida y junta SK500	40
9	<b>8 714 606 021 0</b>	Klemmfeder	Clamp spring	Ressort	Fermo	KLEMVEER NTC SK 120/140/160-4ZB	Muelle de tecla	25
10	<b>8 714 500 034 0</b>	Sensor WW-NTC mit Aderendhülse 6mm	Temperature sensor 6mm	SONDE DE TEMPERATURE 6mm	Sensore termometrico 6mm	Temperatuurvoeler 6mm	Sensor de temperatura 6mm	34
11	<b>8 711 006 060 0</b>	Stecker	Plug	Connecteur	Spina	STEKKER NTC-VOELER ST...1E/SK 300/ST 75	Anection	16
12	<b>8 715 503 422 0</b>	Abdeckung silbergrau	Covering sheet silver grey	Couvercle argent gris	Coperchio argentato grigio	Afdichting zilver grijs	Chapa de protección plata girar	43
13	<b>2 911 060 291 0</b>	Schraube M10x25 (10x)	Screw M10x25 (10x)	Vis M10x25 (10x)	Vite M10x25 (10x)	Schroef M10x25 (10x)	Tornillo M10x25 (10x)	18
13	<b>2 911 060 342 0</b>	Schraube M12x30 (10x)	Screw M12x30 (10x)	Vis M12x30 (10x)	Vite M12x30 (10x)	Schroef M12x30 (10x)	Tornillo M12x30 (10x)	16
	<b>8 710 402 029 0</b>	Kappe	panel	Capot de protection	Tappo	beschermkapje	tapa	20

For:

Ersatzteilliste  
Spare parts list  
Liste des pièces de rechange  
Lista parti di ricambio  
Onderdelenlijst  
Lista de repuestos

**SK160-4ZBS3500 - 7719002074**

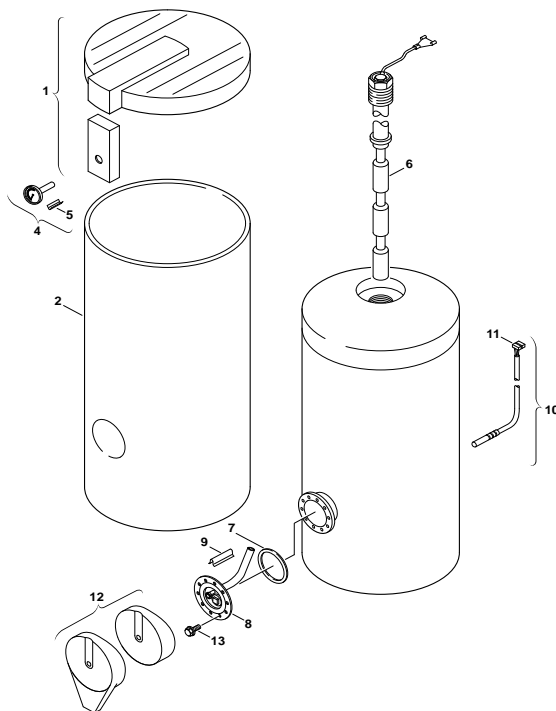

6720901190.AB/G

Pos	Bestell-Nr.	Bezeichnung	Description	Dénomination	Descrizione	Benaming	Descripción	PG
1	8 715 503 188 0	Haube hellgrau	Hood light grey	Carpot gris clair	Coperchio grigio chiaro	DEKSEL SK 160-4ZB (VOOR BOILER 771900193)	Capota girar claro	42
2	8 715 401 349 0	Mantel weiß	Shell white	Habillage blanc	Mantello bianco	MANTEL SK 160-4ZB (VOOR BOILER 771900193)	Carcasa blanco	47
4	8 717 208 050 0	Thermometer	Thermometer	Thermomètre	Termometro	Thermometer	Termómetro	31
5	8 714 606 024 0	Klemmfeder	Clamp spring	RESSORT POUR THERMOMETRE	Fermo	KLEMVEER V/THERMOMETER ST/ISO	Muelle fijación	20
6	8 709 918 638 0	Anode 1"	Anode 1"	Anode 1"	Anodo 1"	ANODE SK 120/140/160-4ZB	Anodo 1"	37
7	8 710 103 096 0	Dichtungs-Set 100x109D - 115/138Dx3 (1x)	Set of seals 100x109D - 115/138Dx3 (1x)	Jeu de joints 100x109D - 115/138Dx3 (1x)	Set guarnizioni 100x109D - 115/138Dx3	DICHTING FLENS SK...ZZB-3ZB (VANAF 070)	conjunto de juntas 100x109D - 115/138Dx3	23
8	8 715 503 170 0	Flansch mit Tauchrohr kpl.	Connecting flange	Bride de raccordement	Flangia	FLENS + DICHTING SK - 3ZB	Conjunto brida y junta SK500	40
9	8 714 606 021 0	Klemmfeder	Clamp spring	Ressort	Fermo	KLEMVEER NTC SK 120/140/160-4ZB	Muelle de tecla	25
10	8 714 500 034 0	Sensor WW-NTC mit Aderendhülse 6mm	Temperature sensor 6mm	SONDE DE TEMPERATURE 6mm	Sensore termometrico 6mm	Temperatuurvoeler 6mm	Sensor de temperatura 6mm	34
11	8 711 006 060 0	Stecker	Plug	Connecteur	Spina	STEKKER NTC-VOELER ST...1E/SK 300/ST 75	Anection	16
12	8 718 006 775 0	Abdeckung hellgrau	Covering sheet light grey	Couvercle gris clair	Coperchio grigio chiaro	AFDEKKAP GRIJS VOOR FLENS BOILER	Chapa de protección girar claro	43
13	2 911 060 291 0	Schraube M10x25 (10x)	Screw M10x25 (10x)	Vis M10x25 (10x)	Vite M10x25 (10x)	Schroef M10x25 (10x)	Tornillo M10x25 (10x)	18
13	2 911 060 342 0	Schraube M12x30 (10x)	Screw M12x30 (10x)	Vis M12x30 (10x)	Vite M12x30 (10x)	Schroef M12x30 (10x)	Tornillo M12x30 (10x)	16
	7 709 500 048	Rückschlagventil 3/4"	Non-return valve 3/4"	Soupape de non-retour 3/4"	Valvola di non ritorno 3/4"	Terugslagklep 3/4"	válvula de retención 3/4"	
	7 709 500 052	Überdruckventil 1/2*3/4" 10 bar	VÁLVULA SEG. 1/2*3/4" 10 bar	VÁLVULA SEG. 1/2*3/4" 10 bar	Valvola di sovrappressione 1/2*3/4" 10 bar	Overdrukvelligheid 1/2*3/4" 10 bar	VÁLVULA SEG. 1/2*3/4" 10 bar	
	8 710 402 029 0	Kappe	panel	Capot de protection	Tappo	beschermkapje	tapa	20

For:

Ersatzteilliste  
Spare parts list  
Liste des pièces de rechange  
Lista parti di ricambio  
Onderdelenlijst  
Lista de repuestos

**SK180-2R - 7719000393**

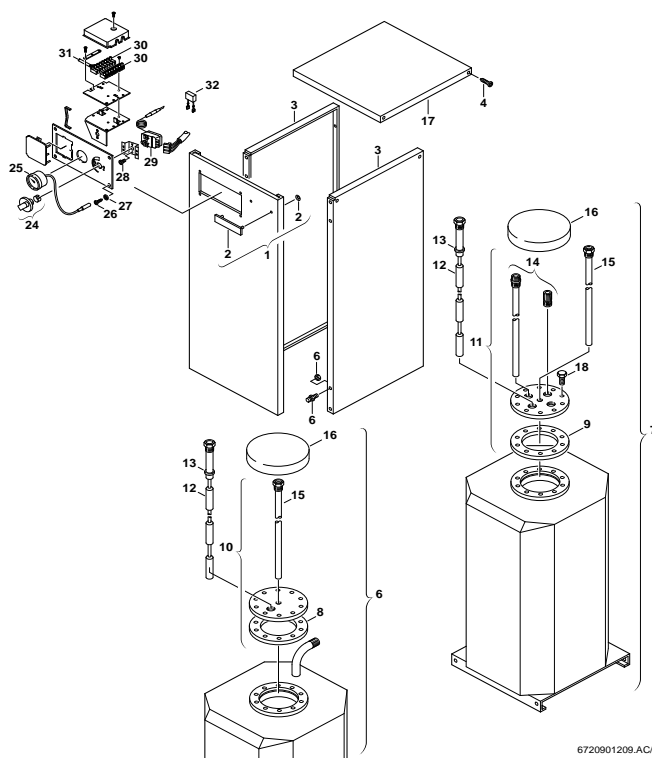

6720901209 AC/G

Pos	Bestell-Nr.	Bezeichnung	Description	Dénomination	Descrizione	Benaming	Descripción	PG
1	8 715 402 110 0	Vorderwand	Cover	Couvercle	Coperchio	Voordeksel	Tapa	47
2	8 701 103 029 0	Warenzeichen	Trade mark badge	Marquage	Targhetta	Fabrieksmerk	Marca	15
3	8 718 007 149 0	Seitenteil	Side panel	Paroi latérale	Pannelo laterale	Zijpaneel	Lateral costado	44
4	8 719 918 772 0	Befestigungssatz	Fixing set	Joint de fixation	Set di fissaggio	Bevestigingsset	Juego piezas de fijacion	23
6	8 715 407 138 0	Behälter	Reservoir	Récipient	Sostegno	Reservoir	Déposito	79
8	8 710 103 088 0	Dichtung	Washer	Joint	Guarnizione	DICHTING FLENS SK 300-3ZB	Junta	19
9	8 719 918 662 0	Dichtung	Washer	Joint	Guarnizione	DICHTING FLENS SK 130-180/ZZ	Junta	26
10	8 715 503 109 0	Flansch	Connecting flange	Trappe de visite	Flangia	Aansluitflens	Brida de conexión	51
11	8 715 503 096 0	Flansch	Connecting flange	Trappe de visite	Flangia	Aansluitflens	Brida de conexión	45
12	8 709 918 506 0	Anode	Anode	Anode	Anodo	ANODE SO 160-160/1-200-2001-SK 160-300-	Anodo	43
13	8 710 103 086 0	Dichtscheibe (10x)	Washer (10x)	Joint (10x)	Guarnizione (10x)	DICHTING ANODE VOOR SO 160	Junta (10x)	22
14	8 710 735 438 0	Ein-/Auslaufrohr Edelstahl, 1253mm	Inlet/Outlet tube	Tube d'arrivée/évacuation	Tubo della presa/ entrata	Inlet/Outlet tube	Pipa del producto/de salida	41
16	8 718 006 397 0	Isolierung	Insulation	Isolation	Isolamento	Isolatie	Aislamiento	23
17	8 718 005 175 0	Deckel weiß	Cover white	Couvercle blanc	Coperchio bianco	Deksel wit	Tapa blanco	42
18	2 911 060 342 0	Schraube M12x30 (10x)	Screw M12x30 (10x)	Vis M12x30 (10x)	Vite M12x30 (10x)	Schroef M12x30 (10x)	Tornillo M12x30 (10x)	16
24	8 712 000 034 0	Drehknopf	Rotary handle	Bouton de réglage	Manopola	Regelknop	Botón rotativo	12
25	8 737 208 991 0	Thermometer	Thermometer	Thermomètre	Termometro	THERMOMETER SO...SK...ZZ-3Z - Z(W)...F	Termómetro	37
26	8 713 403 008 0	Schraube (10x)	Screw	Vis (10x)	Vite (10x)	Schroef (10x)	Tornillo (10x)	11
27	2 916 030 006 0	Sicherungsscheibe (10x)	Retaining ring (10x)	Circlips (10x)	Rondella (10x)	BORGRING UIT TTB 771900055P	Arandela de seguridad (10x)	11
29	8 717 206 186 0	Temperaturregler	Flow thermostat	Thermostat	Thermostat	AQUASTAAT MIWISSELKONTAKT SO 120-160-200	Regulador de temperatura	36
30	8 711 006 046 0	Klemmleiste 24V	Terminal strip 24V	Bornier 24V	Cablaggio 24V	Klemmenstrook 24V	Regleta de bornes 24V	08
31	8 714 401 396 0	Kabel	Cable	Faisceau	Cablaggio	Kabel	Cable	23
32	8 717 301 017 0	Entstörkondensator	ENTSTÖRKONDENSATOR	Condensateur	Condensatore	CONDENSATOR VOOR AQUASTAAT B 737 208 974	Condensador filtro	14

For:

Ersatzteilliste  
Spare parts list  
Liste des pièces de rechange  
Lista parti di ricambio  
Onderdelenlijst  
Lista de repuestos

# SK180-2W - 7719000395

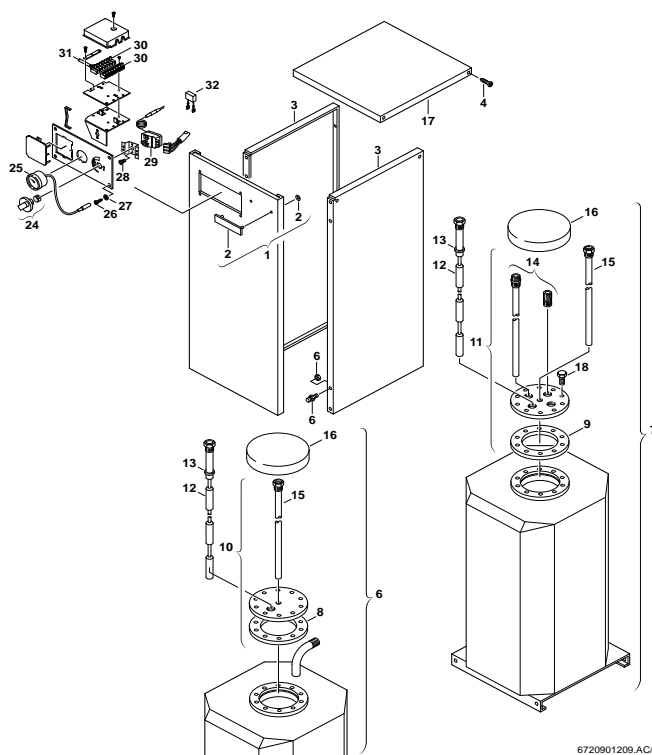

6720901209 AC/G

Pos	Bestell-Nr.	Bezeichnung	Description	Dénomination	Descrizione	Benaming	Descripción	PG
1	8 715 402 110 0	Vorderwand	Cover	Couvercle	Coperchio	Voordeksel	Tapa	47
2	8 701 103 029 0	Warenzeichen	Trade mark badge	Marquage	Targhetta	Fabrieksmerk	Marca	15
3	8 718 007 149 0	Seitenteil	Side panel	Paroi latérale	Pannelo laterale	Zijpaneel	Lateral costado	44
4	8 719 918 772 0	Befestigungssatz	Fixing set	Joint de fixation	Set di fissaggio	Bevestigingsset	Juego piezas de fijacion	23
6	8 715 407 138 0	Behälter	Reservoir	Récipient	Sostegno	Reservoir	Déposito	79
8	8 710 103 088 0	Dichtung	Washer	Joint	Guarnizione	DICHTING FLENS SK 300-3ZB	Junta	19
9	8 719 918 662 0	Dichtung	Washer	Joint	Guarnizione	DICHTING FLENS SK 130-180/ZZ	Junta	26
10	8 715 503 109 0	Flansch	Connecting flange	Trappe de visite	Flangia	Aansluitflens	Brida de conexión	51
11	8 715 503 096 0	Flansch	Connecting flange	Trappe de visite	Flangia	Aansluitflens	Brida de conexión	45
12	8 709 918 506 0	Anode	Anode	Anode	Anodo	ANODE SO 160-160/1-200-2001-SK 180-300-	Anodo	43
13	8 710 103 086 0	Dichtscheibe (10x)	Washer (10x)	Joint (10x)	Guarnizione (10x)	DICHTING ANODE VOOR SO 160	Junta (10x)	22
14	8 710 735 438 0	Ein-/Auslaufrohr Edelstahl, 1253mm	Inlet/Outlet tube	Tube d'arrivée/évacuation	Tubo della presa/ entrata	Inlet/Outlet tube	Pipa del producto/de salida	41
16	8 718 006 397 0	Isolierung	Insulation	Isolation	Isolamento	Isolatie	Aislamiento	23
17	8 718 005 175 0	Deckel weiß	Cover white	Couvercle blanc	Coperchio bianco	Deksel wit	Tapa blanco	42
18	2 911 060 342 0	Schraube M12x30 (10x)	Screw M12x30 (10x)	Vis M12x30 (10x)	Vite M12x30 (10x)	Schroef M12x30 (10x)	Tornillo M12x30 (10x)	16
24	8 712 000 034 0	Drehknopf	Rotary handle	Bouton de réglage	Manopola	Regelknop	Botón rotativo	12
25	8 737 208 991 0	Thermometer	Thermometer	Thermomètre	Termometro	THERMOMETER SO...SK...ZZ-3Z - Z(W)...F	Termómetro	37
26	8 713 403 008 0	Schraube (10x)	Screw	Vis (10x)	Vite (10x)	Schroef (10x)	Tornillo (10x)	11
27	2 916 030 006 0	Sicherungsscheibe (10x)	Retaining ring (10x)	Circlips (10x)	Rondella (10x)	BORGRING UIT TTB 771900055P	Arandela de seguridad (10x)	11
29	8 717 206 186 0	Temperaturregler	Flow thermostat	Thermostat	Thermostat	AQUASTAAT MIWISSELKONTAKT SO 120-160-200	Regulador de temperatura	36
30	8 711 006 046 0	Klemmleiste 24V	Terminal strip 24V	Bornier 24V	Cablaggio 24V	Klemmenstrook 24V	Regleta de bornes 24V	08
31	8 714 401 396 0	Kabel	Cable	Faisceau	Cablaggio	Kabel	Cable	23
32	8 717 301 017 0	Entstörkondensator	ENTSTÖRKONDENSATOR	Condensateur	Condensatore	CONDENSATOR VOOR AQUASTAAT B 737 208 974	Condensador filtro	14

For:

Ersatzteilliste  
 Spare parts list  
 Liste des pièces de rechange  
 Lista parti di ricambio  
 Onderdelenlijst  
 Lista de repuestos

# SK180-2Z - 7719000647

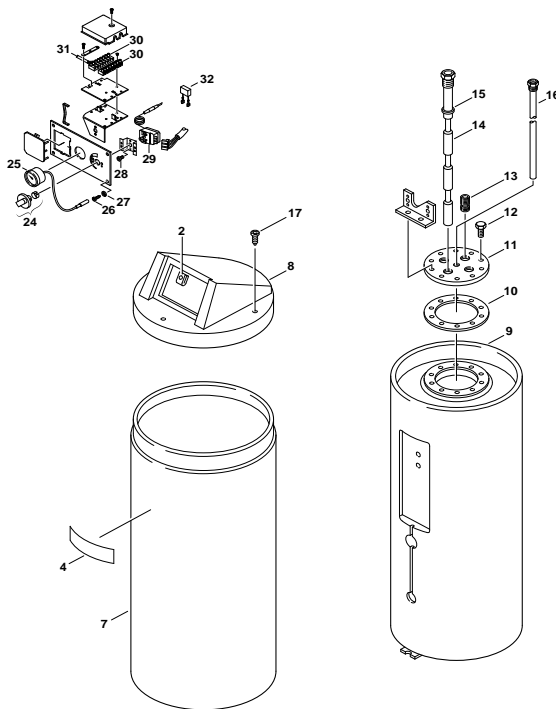

6720901208 AC/G

Pos	Bestell-Nr.	Bezeichnung	Description	Dénomination	Descrizione	Benaming	Descripción	PG
2	8 713 309 026 0	Mutter (10x)	Nut	Ecrou (10x)	Dado (10x)	Moer (10x)	Tuerca (10x)	12
7	8 715 401 107 0	Mantel	Outer_case	Habillage	Mantello	Mantel	Carcasa	50
8	8 718 006 436 0	Haube	Hood	Capot	Carpot	Deksel	Capota	39
9	8 715 407 038 0	Behälter	Reservoir	Réipient	Sostegno	Reservoir	Déposito	79
10	8 719 918 662 0	Dichtung	Washer	Joint	Guarnizione	DICHTING FLENS SK 130-180/2Z	Junta	26
11	8 715 503 086 0	Flansch	Connecting flange	Bride de raccordement	Flangia	FLENS SK..-2Z	Brida de conexión	36
12	2 911 060 342 0	Schraube M12x30 (10x)	Screw M12x30 (10x)	Vis M12x30 (10x)	Vite M12x30 (10x)	Schroef M12x30 (10x)	Tornillo M12x30 (10x)	16
13	8 710 735 438 0	Ein-/Auslaufrohr Edelstahl, 1253mm	Inlet/Outlet tube	Tube d'arrivée/évacuation	Tubo della presa/ entrata	Inlet/Outlet tube	Pipa del producto/de salida	41
14	8 709 918 506 0	Anode	Anode	Anode	Anodo	ANODE SO 160-160/1-200-2001-SK 180-300-	Anodo	43
15	8 710 103 086 0	Dichtscheibe (10x)	Washer (10x)	Joint (10x)	Guarnizione (10x)	DICHTING ANODE VOOR SO 160	Junta (10x)	22
16	8 710 702 055 0	Tauchhülse	Sensor pocket	Douille	Boccola	Dompelhuls	Casquillo de la caldera	39
17	8 713 403 008 0	Schraube (10x)	Screw	Vis (10x)	Vite (10x)	Schroef (10x)	Tornillo (10x)	11
24	8 712 000 034 0	Drehknopf	Rotary handle	Bouton de réglage	Manopola	Regelknop	Botón rotativo	12
25	8 737 208 991 0	Thermometer	Thermometer	Thermomètre	Termometro	THERMOMETER SO...SK...2Z-3Z - Z(W)...F	Termómetro	37
26	8 713 403 008 0	Schraube (10x)	Screw	Vis (10x)	Vite (10x)	Schroef (10x)	Tornillo (10x)	11
27	2 916 030 006 0	Sicherungsscheibe (10x)	Retaining ring (10x)	Circlips (10x)	Rondella (10x)	BORGRING UIT TTB 771900055P	Arandela de seguridad (10x)	11
29	8 717 206 186 0	Temperaturregler	Flow thermostat	Thermostat	Thermostat	AQUASTAAT MWISSELKONTAKT SO 120-160-200	Regulador de temperatura	36
30	8 711 006 046 0	Klemmleiste 24V	Terminal strip 24V	Bornier 24V	Cablaggio 24V	Klemmenstrook 24V	Regleta de bornes 24V	08
31	8 714 401 396 0	Kabel	Cable	Faisceau	Cablaggio	Kabel	Cable	23
32	8 717 301 017 0	Entstörkondensator	ENTSTÖRKONDENSATOR	Condensateur	Condensatore	CONDENSATOR VOOR AQUASTAAT 8 737 206 974	Condensador filtro	14

For:

Ersatzteilliste  
 Spare parts list  
 Liste des pièces de rechange  
 Lista parti di ricambio  
 Onderdelenlijst  
 Lista de repuestos

**SK180-2ZB - 7719000787**

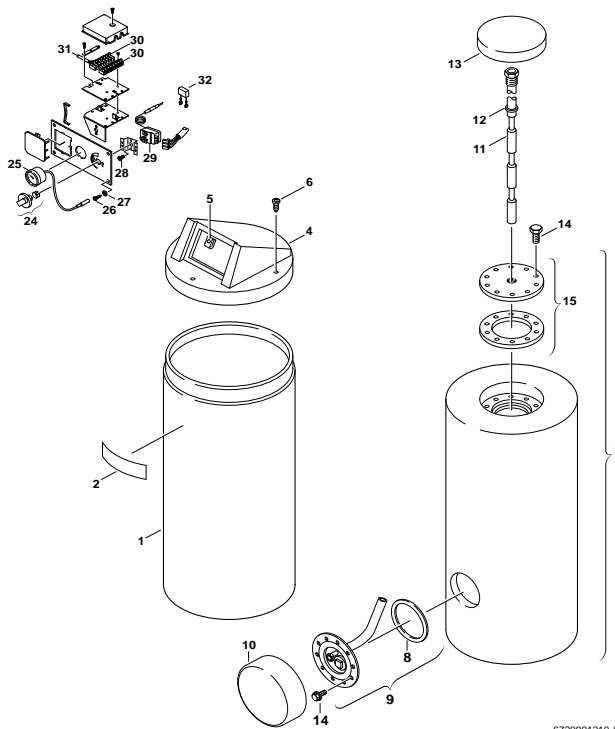

Pos	Bestell-Nr.	Bezeichnung	Description	Dénomination	Descrizione	Benaming	Descripción	PG
1	<b>8 715 401 128 0</b>	Mantel	Front shell	Habillage	Mantello	Mantel	Carcasa	49
4	<b>8 718 006 436 0</b>	Haube	Hood	Capot	Carpot	Deksel	Capota	39
5	<b>8 713 309 026 0</b>	Mutter (10x)	Nut	Ecrou (10x)	Dado (10x)	Moer (10x)	Tuerca (10x)	12
6	<b>8 713 403 008 0</b>	Schraube (10x)	Screw	Vis (10x)	Vite (10x)	Schroef (10x)	Tornillo (10x)	11
7	<b>8 715 407 163 0</b>	Behälter	Reservoir	Récipient	Sostegno	Reservoir	Déposito	79
8	<b>8 710 103 096 0</b>	Dichtungs-Set 100x109D - 115/138Dx3 (1x)	Set of seals 100x109D - 115/138Dx3 (1x)	Jeu de joints 100x109D - 115/138Dx3 (1x)	Set guarnizioni 100x109D - 115/138Dx3	DICHTING FLENS SK - 2ZB-3ZB (VANAF 070)	conjunto de juntas 100x109D - 115/138Dx3	23
9	<b>8 715 503 170 0</b>	Flansch mit Tauchrohr kpl.	Connecting flange	Bride de raccordement	Flangia	FLENS + DICHTING SK - 3ZB	Conjunto brida y junta SK500	40
10	<b>8 718 006 541 0</b>	Abdeckung	Covering sheet	Couvercle	Coperchio	Afdichting	Chapa de protección	22
11	<b>8 709 918 506 0</b>	Anode	Anode	Anode	Anodo	ANODE SO 160-160/1-200-2001-SK 180-300-	Anodo	43
12	<b>8 710 103 086 0</b>	Dichtscheibe (10x)	Washer (10x)	Joint (10x)	Guarnizione (10x)	DICHTING ANODE VOOR SO 160	Junta (10x)	22
13	<b>8 718 006 397 0</b>	Isolierung	Insulation	Isolation	Isolamento	Isolatie	Aislamiento	23
14	<b>2 911 060 342 0</b>	Schraube M12x30 (10x)	Screw M12x30 (10x)	Vis M12x30 (10x)	Vite M12x30 (10x)	Schroef M12x30 (10x)	Tornillo M12x30 (10x)	16
24	<b>8 712 000 034 0</b>	Drehknopf	Rotary handle	Bouton de réglage	Manopola	Regelknop	Botón rotativo	12
25	<b>8 737 208 991 0</b>	Thermometer	Thermometer	Thermomètre	Termometro	THERMOMETER SO -SK - 2Z-3Z - Z(W) - F	Termómetro	37
26	<b>8 713 403 008 0</b>	Schraube (10x)	Screw	Vis (10x)	Vite (10x)	Schroef (10x)	Tornillo (10x)	11
27	<b>2 916 030 006 0</b>	Sicherungsscheibe (10x)	Retaining ring (10x)	Circlips (10x)	Rondella (10x)	BORGRING UIT TTB 771900055P	Arandela de seguridad (10x)	11
29	<b>8 717 206 186 0</b>	Temperaturregler	Flow thermostat	Thermostat	Thermostat	AQUASTAAT MWISSELKONTAKT SO 120-160-200	Regulador de temperatura	36
30	<b>8 711 006 046 0</b>	Klemmleiste 24V	Terminal strip 24V	Bornier 24V	Cablaggio 24V	Klemmenstrook 24V	Regleta de bornes 24V	08
31	<b>8 714 401 396 0</b>	Kabel	Cable	Faisceau	Cablaggio	Kabel	Cable	23
32	<b>8 717 301 017 0</b>	Entstörkondensator	ENTSTÖRKONDENSATOR	Condensateur	Condensatore	CONDENSATOR VOOR AQUASTAAT 8 737 206 974	Condensador filtro	14

For:

Ersatzteilliste  
Spare parts list  
Liste des pièces de rechange  
Lista parti di ricambio  
Onderdelenlijst  
Lista de repuestos

# SK180-3ZB - 7719000959

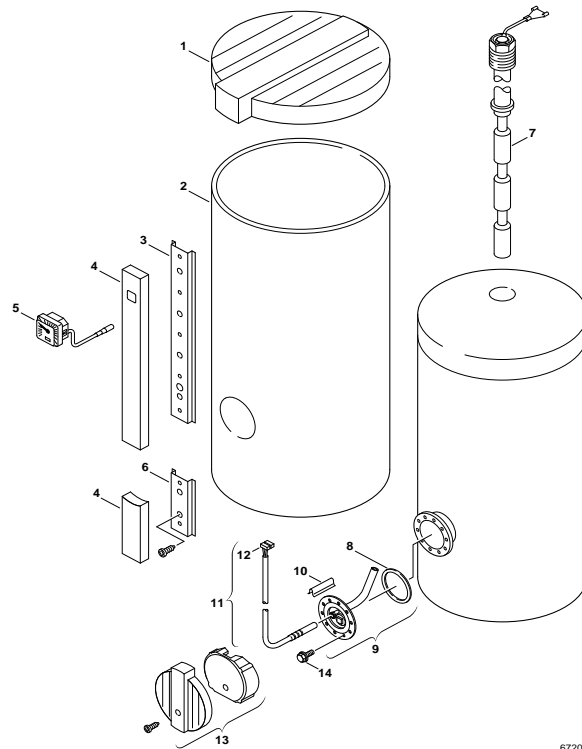

6720901213.AB/G

Pos	Bestell-Nr.	Bezeichnung	Description	Dénomination	Descrizione	Benaming	Descripción	PG
1	8 715 503 162 0	Haube	Hood	Capot	Carpot	BOVENDEKSEL SK 180-3Z	Capota	40
2	8 705 411 193 0	Mantel	Front shell	Habillage	Mantello		Carcasa	52
2	8 715 401 246 0	Mantel	Outer_case	Habillage	Mantello		Carcasa	51
3	8 718 005 456 0	Schiene	Frame	Structure	Telaio		Respaldo	32
4	8 715 503 166 0	Abdeckung	Cover	Couvercle	Coperchio		Chapa de protección	40
5	8 717 208 036 0	Thermometer	Thermometer	Thermomètre	Termometro	THERMOMETER SK...3Z-ST 110-E	Termómetro	37
6	8 718 005 438 0	Schiene	Bar	Barre	Telaio		Respaldo	28
7	8 709 918 666 0	Anode 1"	Anode 1"	Anode 1"	Anodo 1"	ANODE (KETTING) ST120/160-1E /SK 130-3Z	Anodo 1"	43
8	8 710 103 096 0	Dichtungs-Set 100x109D - 115/138Dx3 (1x)	Set of seals 100x109D - 115/138Dx3 (1x)	Jeu de joints 100x109D - 115/138Dx3 (1x)	Set guarnizioni 100x109D - 115/138Dx3	DICHTING FLENS SK...2ZB (VANAF 070)	conjunto de juntas 100x109D - 115/138Dx3	23
9	8 715 503 170 0	Flansch mit Tauchrohr kpl.	Connecting flange	Bride de raccordement	Flangia	FLENS + DICHTING SK - 3ZB	Conjunto brida y junta SK500	40
10	8 714 606 021 0	Klemmfeder	Clamp spring	Ressort	Fermo	KLEIMVEER NTC SK120/140/160-4ZB	Muelle de tecla	25
11	8 714 500 034 0	Sensor WW-NTC mit Aderendhülse 6m	Temperature sensor 6mm	SONDE DE TEMPERATURE 6mm	Sensore termometrico 6mm	Temperatuurvoeler 6mm	Sensor de temperatura 6mm	34
12	8 711 006 060 0	Stecker	Plug	Connecteur	Spina	STEKKER NTC-VOELER ST...1E/SK 300/ST 75	Anection	16
13	8 715 503 163 0	Abdeckung	Cover	Couvercle	Coperchio		Chapa de protección	35
14	2 911 060 342 0	Schraube M12x30 (10x)	Screw M12x30 (10x)	Vis M12x30 (10x)	Vite M12x30 (10x)	Schroef M12x30 (10x)	Tornillo M12x30 (10x)	16
	7 719 001 172	SE8 Schalteinsatz	SE8 switch insert	SE8 Insert de commutation	SE8 Frutto	INZETSTUK	SE-8 MODULO CONTROL SO...1	

For:

**Ersatzteilliste**  
**Spare parts list**  
**Liste des pièces de rechange**  
**Lista parti di ricambio**  
**Onderdelenlijst**  
**Lista de repuestos**

# SK180-3ZBS3500 - 7719001461

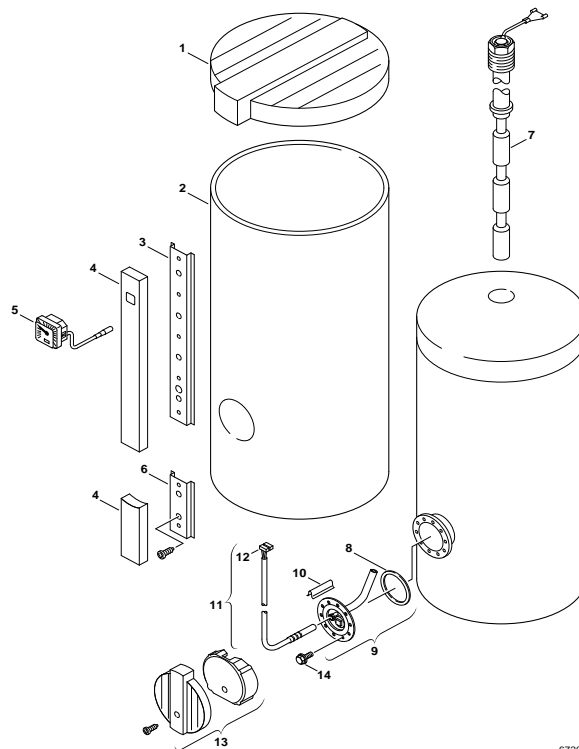

6720901213.AB/G

Pos	Bestell-Nr.	Bezeichnung	Description	Dénomination	Descrizione	Benaming	Descripción	PG
1	8 715 503 162 0	Haube	Hood	Capot	Carpot	BOVENDEKSEL SK 180-3Z	Capota	40
2	8 705 411 193 0	Mantel	Front shell	Habillage	Mantello	Mantel	Carcasa	52
3	8 718 005 456 0	Schiene	Frame	Structure	Telaio	Frame	Respaldo	32
4	8 715 503 166 0	Abdeckung	Cover	Couvercle	Coperchio	Afdichting	Chapa de protección	40
5	8 717 208 036 0	Thermometer	Thermometer	Thermomètre	Termometro	THERMOMETER SK...3Z-ST 110-E	Termómetro	37
6	8 718 005 438 0	Schiene	Bar	Barre	Telaio	Strip	Respaldo	28
7	8 709 918 666 0	Anode 1"	Anode 1"	Anode 1"	Anodo 1"	ANODE (KETTING) ST120/160-1E /SK 130-3Z	Anodo 1"	43
8	8 710 103 096 0	Dichtungs-Set 100x109D - 115/138Dx3 (1x)	Set of seals 100x109D - 115/138Dx3 (1x)	Jeu de joints 100x109D - 115/138Dx3 (1x)	Set guarnizioni 100x109D - 115/138Dx3	DICHTING FLENS SK...2ZB(VANAF 070)	conjunto de juntas 100x109D - 115/138Dx3	23
9	8 715 503 170 0	Flansch mit Tauchrohr kpl.	Connecting flange	Bride de raccordement	Flangia	FLENS + DICHTING SK - 3ZB	Conjunto brida y junta SK500	40
10	8 714 606 021 0	Klemmfeder	Clamp spring	Ressort	Fermo	KLEMMVEER NTC SK120/140/160-4ZB	Muelle de tecla	25
11	8 714 500 034 0	Sensor WW-NTC mit Aderendhülse 6m	Temperature sensor 6mm	SONDE DE TEMPERATURE 6mm	Sensore termometrico 6mm	Temperatuurvoeler 6mm	Sensor de temperatura 6mm	34
12	8 711 006 060 0	Stecker	Plug	Connecteur	Spina	STEKKER NTC-VOELER ST...1E/SK 300/ST 75	Anection	16
13	8 715 503 163 0	Abdeckung	Cover	Couvercle	Coperchio	Afdichting	Chapa de protección	35
14	2 911 060 342 0	Schraube M12x30 (10x)	Screw M12x30 (10x)	Vis M12x30 (10x)	Vite M12x30 (10x)	Schroef M12x30 (10x)	Tornillo M12x30 (10x)	16
	7 719 001 172	SE8 Schalteinsatz	SE8 switch insert	SE8 Insert de commutation	SE8 Frutto	INZETSTUK	SE-8 MODULO CONTROL SO...1	

For:



Ersatzteilliste  
 Spare parts list  
 Liste des pièces de rechange  
 Lista parti di ricambio  
 Onderdelenlijst  
 Lista de repuestos

# SK200-4ZB/C2 - 7719002121

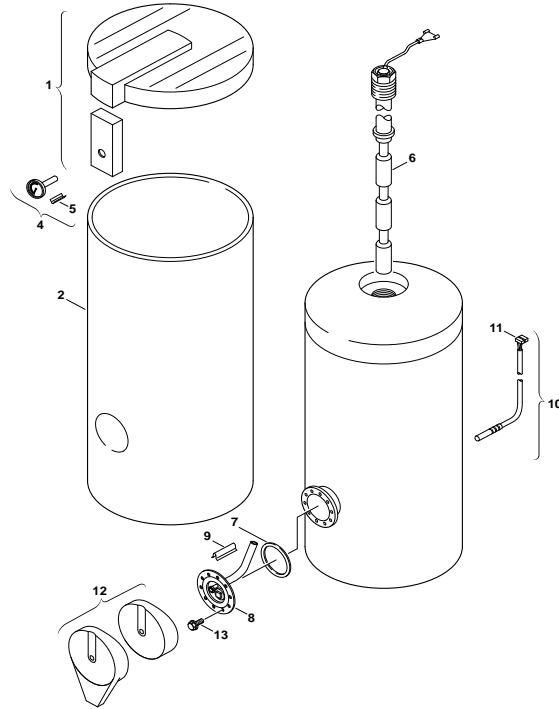

6720901190.AB/G

Pos	Bestell-Nr.	Bezeichnung	Description	Dénomination	Descrizione	Benaming	Descripción	PG
1	8 715 503 417 0	Haube silbergrau	Hood silver grey	Carpot argent gris	Coperchio argentato grigio	Deksel zilvergrijs	Capota plata girar	42
2	8 715 401 396 0	Mantel silbergrau	Front shell silver grey	Habillage argent gris	Mantello argentato grigio	Mantel zilver grijs	Carcasa plata girar	47
4	8 717 208 050 0	Thermometer	Thermometer	Thermomètre	Termometro	Thermometer	Termómetro	31
5	8 714 606 024 0	Klemmfeder	Clamp spring	RESSORT POUR THERMOMETRE	Fermo	KLEMVEER V/THERMOMETER ST/SO	Muelle fijación	20
6	8 709 918 638 0	Anode 1"	Anode 1"	Anode 1"	Anodo 1"	ANODE SK 120/140/160-4ZB	Anodo 1"	37
7	8 710 103 096 0	Dichtungs-Set 100x109D - 115/138Dx3 (1x)	Set of seals 100x109D - 115/138Dx3 (1x)	Jeu de joints 100x109D - 115/138Dx3 (1x)	Set guarnizioni 100x109D - 115/138Dx3	DICHTING FLENS SK...2ZB-3ZB (VANAF 070)	conjunto de juntas 100x109D - 115/138Dx3	23
8	8 715 503 170 0	Flansch mit Tauchrohr kpl.	Connecting flange	Bride de raccordement	Flangia	FLENS + DICHTING SK - 3ZB	Conjunto brida y junta SK500	40
9	8 714 606 021 0	Klemmfeder	Clamp spring	Ressort	Fermo	KLEMVEER NTC SK120/140/160-4ZB	Muelle de tecla	25
10	8 714 500 034 0	Sensor WW-NTC mit Aderendhülse 6mm	Temperature sensor 6mm	SONDE DE TEMPERATURE 6mm	Sensore termometrico 6mm	Temperatuurvoeler 6mm	Sensor de temperatura 6mm	34
11	8 711 006 060 0	Stecker	Plug	Connecteur	Spina	STEKKER NTC-VOELER ST...1E/SK 300/ST 75	Anection	16
12	8 715 503 422 0	Abdeckung silbergrau	Covering sheet silver grey	Couvercle argent gris	Coperchio argentato grigio	Afdichting zilver grijs	Chapa de protección plata girar	43
13	2 911 060 291 0	Schraube M10x25 (10x)	Screw M10x25 (10x)	Vis M10x25 (10x)	Vite M10x25 (10x)	Schroef M10x25 (10x)	Tornillo M10x25 (10x)	18
13	2 911 060 342 0	Schraube M12x30 (10x)	Screw M12x30 (10x)	Vis M12x30 (10x)	Vite M12x30 (10x)	Schroef M12x30 (10x)	Tornillo M12x30 (10x)	16
	8 710 402 029 0	Kappe	panel	Capot de protection	Tappo	beschermkapje	tapa	20
For:								

Ersatzteilliste  
Spare parts list  
Liste des pièces de rechange  
Lista parti di ricambio  
Onderdelenlijst  
Lista de repuestos

# SK200-4ZBS3500 - 7719002075

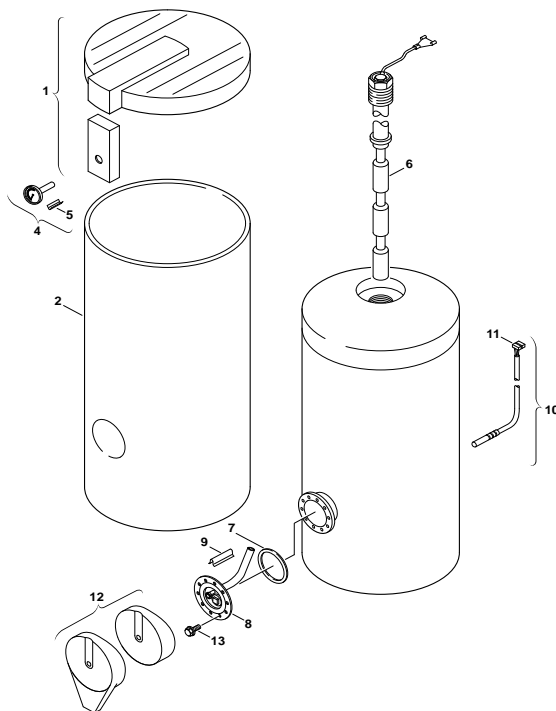

6720901190.AB/G

Pos	Bestell-Nr.	Bezeichnung	Description	Dénomination	Descrizione	Benaming	Descripción	PG
1	8 715 503 188 0	Haube hellgrau	Hood light grey	Carpot gris clair	Coperchio grigio chiaro	DEKSEL SK 160-4ZB (VOOR BOILER 771900193)	Capota girar claro	42
2	8 715 401 350 0	Mantel weiß	Shell white	Habillage blanc	Mantello bianco	MANTEL SK 200-4ZB (VOOR BOILER 771900193)	Carcasa blanco	47
4	8 717 208 050 0	Thermometer	Thermometer	Thermomètre	Termometro	Thermometer	Termómetro	31
5	8 714 606 024 0	Klemmfeder	Clamp spring	RESSORT POUR THERMOMETRE	Fermo	KLEMVEER V/THERMOMETER ST/ISO	Muelle fijación	20
6	8 709 918 638 0	Anode 1"	Anode 1"	Anode 1"	Anodo 1"	ANODE SK 120/140/160-4ZB	Anodo 1"	37
7	8 710 103 096 0	Dichtungs-Set 100x109D - 115/138Dx3 (1x)	Set of seals 100x109D - 115/138Dx3 (1x)	Jeu de joints 100x109D - 115/138Dx3 (1x)	Set guarnizioni 100x109D - 115/138Dx3	DICHTING FLENS SK...ZZB-3ZB (VANAF 070)	conjunto de juntas 100x109D - 115/138Dx3	23
8	8 715 503 170 0	Flansch mit Tauchrohr kpl.	Connecting flange	Bride de raccordement	Flangia	FLENS + DICHTING SK - 3ZB	Conjunto brida y junta SK500	40
9	8 714 606 021 0	Klemmfeder	Clamp spring	Ressort	Fermo	KLEMVEER NTC SK 120/140/160-4ZB	Muelle de tecla	25
10	8 714 500 034 0	Sensor WW-NTC mit Aderendhülse 6mm	Temperature sensor 6mm	SONDE DE TEMPERATURE 6mm	Sensore termometrico 6mm	Temperatuurvoeler 6mm	Sensor de temperatura 6mm	34
11	8 711 006 060 0	Stecker	Plug	Connecteur	Spina	STEKKER NTC-VOELER ST...1E/SK 300/ST 75	Anection	16
12	8 718 006 775 0	Abdeckung hellgrau	Covering sheet light grey	Couvercle gris clair	Coperchio grigio chiaro	AFDEKKAP GRIJS VOOR FLENS BOILER	Chapa de protección girar claro	43
13	2 911 060 291 0	Schraube M10x25 (10x)	Screw M10x25 (10x)	Vis M10x25 (10x)	Vite M10x25 (10x)	Schroef M10x25 (10x)	Tornillo M10x25 (10x)	18
13	2 911 060 342 0	Schraube M12x30 (10x)	Screw M12x30 (10x)	Vis M12x30 (10x)	Vite M12x30 (10x)	Schroef M12x30 (10x)	Tornillo M12x30 (10x)	16
	7 709 500 048	Rückschlagventil 3/4"	Non-return valve 3/4"	Soupape de non-retour 3/4"	Valvola di non ritorno 3/4"	Terugslagklep 3/4"	válvula de retención 3/4"	
	7 709 500 052	Überdruckventil 1/2*3/4" 10 bar	VÁLVULA SEG. 1/2*3/4" 10 bar	VÁLVULA SEG. 1/2*3/4" 10 bar	Valvola di sovrappressione 1/2*3/4" 10 bar	Overdrukvelligheid 1/2*3/4" 10 bar	VÁLVULA SEG. 1/2*3/4" 10 bar	
	8 710 402 029 0	Kappe	panel	Capot de protection	Tappo	beschermkapje	tapa	20

For:

Ersatzteilliste  
Spare parts list  
Liste des pièces de rechange  
Lista parti di ricambio  
Onderdelenlijst  
Lista de repuestos

# SK220-3ZB - 7719000960

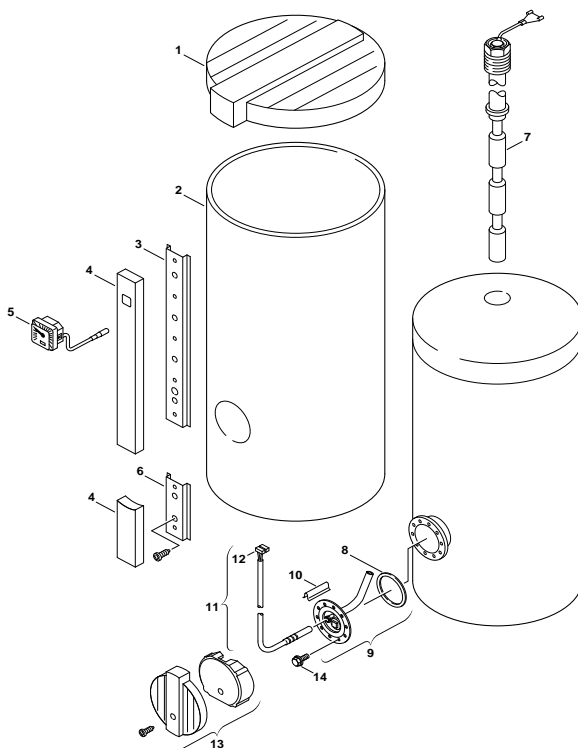

6720901213.AB/G

Pos	Bestell-Nr.	Bezeichnung	Description	Dénomination	Descrizione	Benaming	Descripción	PG
1	8 715 503 162 0	Haube	Hood	Capot	Carpot	BOVENDEKSEL SK 180-3Z	Capota	40
2	8 705 411 194 0	Mantel	Front shell	Habillage	Mantello		Carcasa	53
2	8 715 401 247 0	Mantel	Outer_case	Habillage	Mantello		Carcasa	52
3	8 718 005 457 0	Schiene	Frame	Structure	Telaio		Respaldo	33
4	8 715 503 166 0	Abdeckung	Cover	Couvercle	Coperchio		Chapa de protección	40
5	8 717 208 036 0	Thermometer	Thermometer	Thermomètre	Termometro	THERMOMETER SK...3Z-ST 110-E	Termómetro	37
6	8 718 005 438 0	Schiene	Bar	Barre	Telaio		Respaldo	28
7	8 709 918 666 0	Anode 1"	Anode 1"	Anode 1"	Anodo 1"	ANODE (KETTING) ST120/160-1E /SK 130-3Z	Anodo 1"	43
8	8 710 103 096 0	Dichtungs-Set 100x109D - 115/138Dx3 (1x)	Set of seals 100x109D - 115/138Dx3 (1x)	Jeu de joints 100x109D - 115/138Dx3 (1x)	Set guarnizioni 100x109D - 115/138Dx3	DICHTING FLENS SK...2ZB (VANAF 070)	conjunto de juntas 100x109D - 115/138Dx3	23
9	8 715 503 170 0	Flansch mit Tauchrohr kpl.	Connecting flange	Bride de raccordement	Flangia	FLENS + DICHTING SK - 3ZB	Conjunto brida y junta SK500	40
10	8 714 606 021 0	Klemmfeder	Clamp spring	Ressort	Fermo	KLEIMVEER NTC SK120/140/160-4ZB	Muelle de tecla	25
11	8 714 500 034 0	Sensor WW-NTC mit Aderendhülse 6m	Temperature sensor 6mm	SONDE DE TEMPERATURE 6mm	Sensore termometrico 6mm	Temperatuurvoeler 6mm	Sensor de temperatura 6mm	34
12	8 711 006 060 0	Stecker	Plug	Connecteur	Spina	STEKKER NTC-VOELER ST...1E/SK 300/ST 75	Anection	16
13	8 715 503 163 0	Abdeckung	Cover	Couvercle	Coperchio		Chapa de protección	35
14	2 911 060 342 0	Schraube M12x30 (10x)	Screw M12x30 (10x)	Vis M12x30 (10x)	Vite M12x30 (10x)	Schroef M12x30 (10x)	Tornillo M12x30 (10x)	16
	7 719 001 172	SE8 Schalteinsatz	SE8 switch insert	SE8 Insert de commutation	SE8 Frutto	INZETSTUK	SE-8 MODULO CONTROL SO...1	

For:

Ersatzteilliste  
Spare parts list  
Liste des pièces de rechange  
Lista parti di ricambio  
Onderdelenlijst  
Lista de repuestos

# SK220-3ZBS3500 - 7719001462

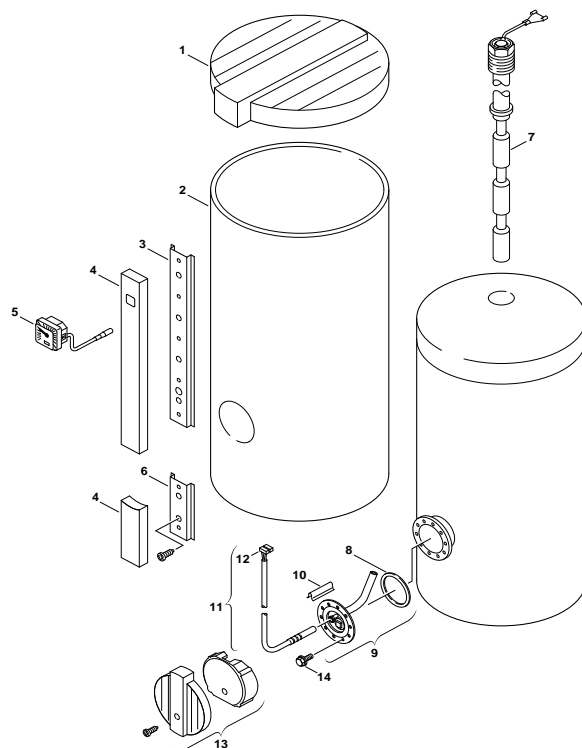

Pos	Bestell-Nr.	Bezeichnung	Description	Dénomination	Descrizione	Benaming	Descripción	PG
1	8 715 503 162 0	Haube	Hood	Capot	Carpot	BOVENDEKSEL SK 180-3Z	Capota	40
2	8 705 411 194 0	Mantel	Front shell	Habillage	Mantello	Mantel	Carcasa	53
3	8 718 005 457 0	Schiene	Frame	Structure	Telaio	Frame	Respaldo	33
4	8 715 503 166 0	Abdeckung	Cover	Couvercle	Coperchio	Afdichting	Chapa de protección	40
5	8 717 208 036 0	Thermometer	Thermometer	Thermomètre	Termometro	THERMOMETER SK...3Z-ST 110-E	Termómetro	37
6	8 718 005 438 0	Schiene	Bar	Barre	Telaio	Strip	Respaldo	28
7	8 709 918 666 0	Anode 1"	Anode 1"	Anode 1"	Anodo 1"	ANODE (KETTING) ST120/160-1E /SK 130-3Z	Anodo 1"	43
8	8 710 103 096 0	Dichtungs-Set 100x109D - 115/138Dx3 (1x)	Set of seals 100x109D - 115/138Dx3 (1x)	Jeu de joints 100x109D - 115/138Dx3 (1x)	Set guarnizioni 100x109D - 115/138Dx3	DICHTING FLENS SK...2ZB1-3ZB (VANAF 070	conjunto de juntas 100x109D - 115/138Dx3	23
9	8 715 503 170 0	Flansch mit Tauchrohr kpl.	Connecting flange	Bride de raccordement	Flangia	FLENS + DICHTING SK - 3ZB	Conjunto brida y junta SK500	40
10	8 714 606 021 0	Klemmfeder	Clamp spring	Ressort	Fermo	KLEMVEER NTC SK120/140/160-4ZB	Muelle de tecla	25
11	8 714 500 034 0	Sensor WW-NTC mit Aderendhülse 6m	Temperature sensor 6mm	SONDE DE TEMPERATURE 6mm	Sensore termometrico 6mm	Temperatuurvoeler 6mm	Sensor de temperatura 6mm	34
12	8 711 006 060 0	Stecker	Plug	Connecteur	Spina	STEKKER NTC-VOELER ST...1E/SK 300/ST 75	Anection	16
13	8 715 503 163 0	Abdeckung	Cover	Couvercle	Coperchio	Afdichting	Chapa de protección	35
14	2 911 060 342 0	Schraube M12x30 (10x)	Screw M12x30 (10x)	Vis M12x30 (10x)	Vite M12x30 (10x)	Schroef M12x30 (10x)	Tornillo M12x30 (10x)	16
	7 719 001 172	SE8 Schalteinsatz	SE8 switch insert	SE8 Insert de commutation	SE8 Frutto	INZETSTUK	SE-8 MODULO CONTROL SO...1	
For:								

Ersatzteilliste  
Spare parts list  
Liste des pièces de rechange  
Lista parti di ricambio  
Onderdelenlijst  
Lista de repuestos

**SK230-2Z - 7719000778**

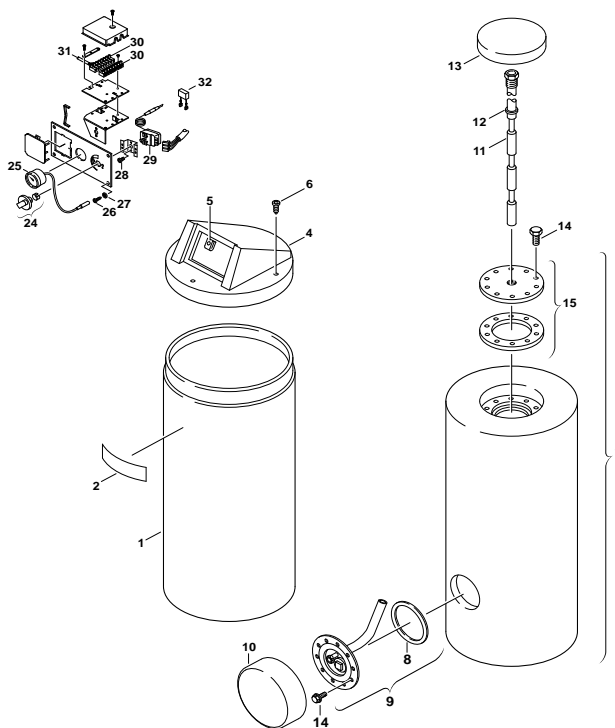

6720901210.AC/G

Pos	Bestell-Nr.	Bezeichnung	Description	Dénomination	Descrizione	Benaming	Descripción	PG
1	<b>8 715 401 144 0</b>	Mantel	Front shell	Habillage	Mantello	Mantel	Carcasa	47
4	<b>8 718 006 436 0</b>	Haube	Hood	Capot	Carpot	Deksel	Capota	39
5	<b>8 713 309 026 0</b>	Mutter (10x)	Nut	Ecrou (10x)	Dado (10x)	Moer (10x)	Tuerca (10x)	12
6	<b>8 713 403 008 0</b>	Schraube (10x)	Screw	Vis (10x)	Vite (10x)	Schroef (10x)	Tornillo (10x)	11
8	<b>8 710 103 096 0</b>	Dichtungs-Set 100x109D - 115/138Dx3 (1x)	Set of seals 100x109D - 115/138Dx3 (1x)	Jeu de joints 100x109D - 115/138Dx3 (1x)	Set guarnizioni 100x109D - 115/138Dx3	DICHTING FLENS SK...22B-3ZB (VANAF 070)	conjunto de juntas 100x109D - 115/138Dx3	23
9	<b>8 715 503 170 0</b>	Flansch mit Tauchrohr kpl.	Connecting flange	Bride de raccordement	Flangia	FLENS + DICHTING SK - 3ZB	Conjunto brida y junta SK500	40
10	<b>8 718 006 541 0</b>	Abdeckung	Covering sheet	Couvercle	Coperchio	Afdichting	Chapa de protección	22
11	<b>8 709 918 506 0</b>	Anode	Anode	Anode	Anodo	ANODE SO 160-160/1-200-200/1-SK 180-300-	Anodo	43
12	<b>8 710 103 086 0</b>	Dichtscheibe (10x)	Washer (10x)	Joint (10x)	Guarnizione (10x)	DICHTING ANODE VOOR SO 160	Junta (10x)	22
13	<b>8 718 006 397 0</b>	Isolierung	Insulation	Isolation	Isolamento	Isolatie	Aislamiento	23
14	<b>2 911 060 342 0</b>	Schraube M12x30 (10x)	Screw M12x30 (10x)	Vis M12x30 (10x)	Vite M12x30 (10x)	Schroef M12x30 (10x)	Tornillo M12x30 (10x)	16
24	<b>8 712 000 034 0</b>	Drehknopf	Rotary handle	Bouton de réglage	Manopola	Regelknop	Botón rotativo	12
25	<b>8 737 208 991 0</b>	Thermometer	Thermometer	Thermomètre	Termometro	THERMOMETER SO...SK...22-3Z - Z(W)...F	Termómetro	37
26	<b>8 713 403 008 0</b>	Schraube (10x)	Screw	Vis (10x)	Vite (10x)	Schroef (10x)	Tornillo (10x)	11
27	<b>2 916 030 006 0</b>	Sicherungsscheibe (10x)	Retaining ring (10x)	Circlips (10x)	Rondella (10x)	BORGRING UIT TTB 771900055P	Arandela de seguridad (10x)	11
29	<b>8 717 206 186 0</b>	Temperaturregler	Flow thermostat	Thermostat	Thermostat	AQUASTAAT MWISSELKONTAKT SO 120-160-200	Regulador de temperatura	36
30	<b>8 711 006 046 0</b>	Klemmleiste 24V	Terminal strip 24V	Bornier 24V	Cablaggio 24V	Klemmenstrook 24V	Regleta de bornes 24V	08
31	<b>8 714 401 396 0</b>	Kabel	Cable	Faisceau	Cablaggio	Kabel	Cable	23
32	<b>8 717 301 017 0</b>	Entstörkondensator	ENTSTÖRKONDENSATOR	Condensateur	Condensatore	CONDENSATOR VOOR AQUASTAAT 8 737 206 974	Condensador filtro	14

For:

**Ersatzteilliste**  
**Spare parts list**  
**Liste des pièces de rechange**  
**Lista parti di ricambio**  
**Onderdelenlijst**  
**Lista de repuestos**

**SK300-1SOLAR - 7739300909**

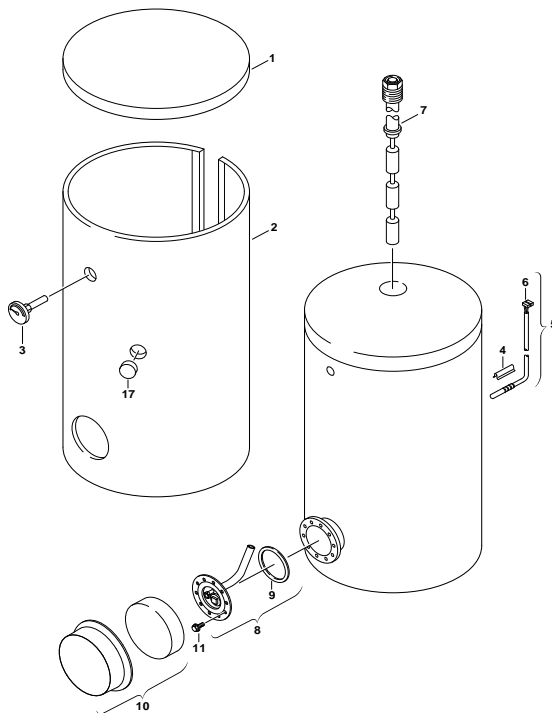

6720901194.AC/G

Pos	Bestell-Nr.	Bezeichnung	Description	Dénomination	Descrizione	Benaming	Descripción	PG
1	8 715 503 348 0	Haube hellgrau	Hood light grey	Carpot gris clair	Coperchio grigio chiaro	Deksel lichtgrijs	Capota girar claro	41
2	8 715 401 346 0	Mantel weiß	Shell white	Habillage blanc	Mantello bianco	MANTEL SK 300-1 SOLAR (7719001929)	Carcasa blanco	49
3	8 717 208 050 0	Thermometer	Thermometer	Thermomètre	Termometro	Thermometer	Termómetro	31
4	8 714 606 021 0	Klemmfeder	Clamp spring	Ressort	Fermo	KLEMFVEER NTC SK120/140/160-4ZB	Muelle de tecla	25
5	8 714 500 034 0	Sensor WW-NTC mit Aderendhülse 6mm	Temperature sensor 6mm	SONDE DE TEMPERATURE 6mm	Sensore termometrico 6mm	Temperatuurvoeler 6mm	Sensor de temperatura 6mm	34
6	8 711 006 060 0	Stecker	Plug	Connecteur	Spina	STEKKER NTC-VOELER ST.-1E/SK 300ST 75	Anection	16
7	8 709 918 506 0	Anode	Anode	Anode	Anodo	ANODE SO 160-160/1-200-200/1-SK 180-300-	Anodo	43
7	8 709 918 666 0	Anode 1"	Anode 1"	Anode 1"	Anodo 1"	ANODE (KETTING) ST120/160-1E /SK 130-3Z	Anodo 1"	43
8	8 715 503 170 0	Flansch mit Tauchrohr kpl.	Connecting flange	Bride de raccordement	Flangia	FLENS + DICHTING SK - 3ZB	Conjunto brida y junta SK500	40
9	8 710 103 096 0	Dichtungs-Set 100x109D - 115/138Dx3 (1x)	Set of seals 100x109D - 115/138Dx3 (1x)	Jeu de joints 100x109D - 115/138Dx3 (1x)	Set guarnizioni 100x109D - 115/138Dx3	DICHTING FLENS SK-22B/3ZB (VANAF 070)	conjunto de juntas 100x109D - 115/138Dx3	23
10	8 715 503 346 0	Abdeckung hellgrau	Covering sheet light grey	Couvercle gris clair	Coperchio grigio chiaro	DEKSEL SK 300-1/400-1/500-1 SOLAR	Chapa de protección girar claro	33
11	2 911 060 291 0	Schraube M10x25 (10x)	Screw M10x25 (10x)	Vis M10x25 (10x)	Vite M10x25 (10x)	Schroef M10x25 (10x)	Tornillo M10x25 (10x)	18
11	2 911 060 342 0	Schraube M12x30 (10x)	Screw M12x30 (10x)	Vis M12x30 (10x)	Vite M12x30 (10x)	Schroef M12x30 (10x)	Tornillo M12x30 (10x)	16
17	8 715 503 239 0	Isolierung	Insulation	Bouchon	Isolamento	ISOLATIE SK 300-1 SOLAR (7719001929)	Aislamiento	23
	8 718 220 038 0	Hülse 1"	Sleeve 1"	Douille 1"	Bocchetta 1"	ISOLATIE DEKSEL SK 300-1/400-1/500-1 SOL	Manguito 1"	09

For:

Ersatzteilliste  
 Spare parts list  
 Liste des pièces de rechange  
 Lista parti di ricambio  
 Onderdelenlijst  
 Lista de repuestos

# SK300-1SOLAR S0800 - 7739300915

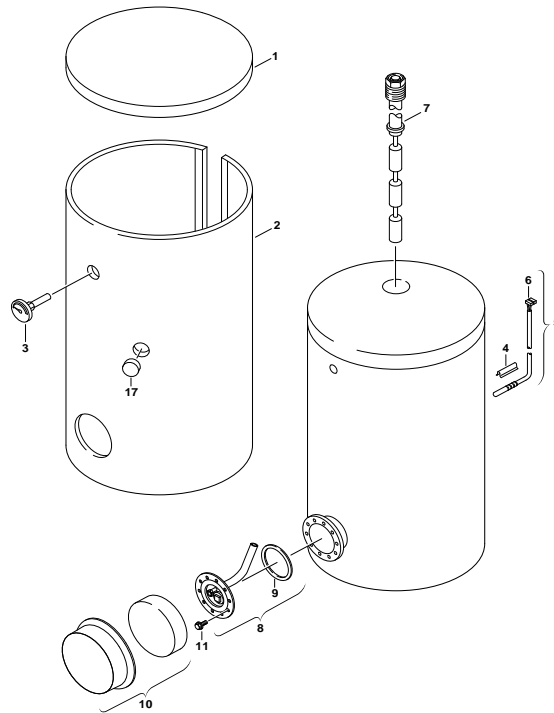

6720901194.AC/G

Pos	Bestell-Nr.	Bezeichnung	Description	Dénomination	Descrizione	Benaming	Descripción	PG
1	8 715 503 348 0	Haube hellgrau	Hood light grey	Caprot gris clair	Coperchio grigio chiaro	Deksel lichtgrijs	Capota girar claro	41
2	8 715 401 346 0	Mantel weiß	Shell white	Habillage blanc	Mantello bianco	MANTEL SK 300-1 SOLAR (7719001929)	Carcasa blanco	49
3	8 717 208 050 0	Thermometer	Thermometer	Thermomètre	Termometro	Thermometer	Termómetro	31
4	8 714 606 021 0	Klemmfeder	Clamp spring	Ressort	Fermo	KLEEMVEER NTC SK120/140/160-4ZB	Muelle de tecla	25
5	8 714 500 034 0	Sensor WW-NTC mit Aderendhülse 6mm	Temperature sensor 6mm	SONDE DE TEMPERATURE 6mm	Sensore termometrico 6mm	Temperatuurvoeler 6mm	Sensor de temperatura 6mm	34
6	8 711 006 060 0	Stecker	Plug	Connecteur	Spina	STEKKER NTC-VOELER ST.-1E/SK 300ST 75	Anection	16
7	8 709 918 506 0	Anode	Anode	Anode	Anodo	ANODE SO 160-160/1-200-200/1-SK 180-300-	Anodo	43
7	8 709 918 666 0	Anode 1"	Anode 1"	Anode 1"	Anodo 1"	ANODE (KETTING)ST120/160-1E /SK 130-3Z	Anodo 1"	43
8	8 715 503 170 0	Flansch mit Tauchrohr kpl.	Connecting flange	Bride de raccordement	Flangia	FLENS + DICHTING SK - 3ZB	Conjunto brida y junta SK500	40
9	8 710 103 096 0	Dichtungs-Set 100x109D - 115/138Dx3 (1x)	Set of seals 100x109D - 115/138Dx3 (1x)	Jeu de joints 100x109D - 115/138Dx3 (1x)	Set guarnizioni 100x109D - 115/138Dx3	DICHTING FLENS SK.-2ZB-3ZB (VANAF 070)	conjunto de juntas 100x109D - 115/138Dx3	23
10	8 715 503 346 0	Abdeckung hellgrau	Covering sheet light grey	Couvercle gris clair	Coperchio grigio chiaro	DEKSEL SK 300-1/400-1/500-1 SOLAR	Chapa de protección girar claro	33
11	2 911 060 291 0	Schraube M10x25 (10x)	Screw M10x25 (10x)	Vis M10x25 (10x)	Vite M10x25 (10x)	Schroef M10x25 (10x)	Tornillo M10x25 (10x)	18
11	2 911 060 342 0	Schraube M12x30 (10x)	Screw M12x30 (10x)	Vis M12x30 (10x)	Vite M12x30 (10x)	Schroef M12x30 (10x)	Tornillo M12x30 (10x)	16
17	8 715 503 239 0	Isolierung	Insulation	Bouchon	Isolamento	ISOLATIE SK 300-1 SOLAR (7719001929)	Aislamiento	23
	8 718 220 038 0	Hülse 1"	Sleeve 1"	Douille 1"	Bocchetta 1"	ISOLATIE DEKSEL SK 300-1/400-1/500-1 SOL	Manguito 1"	09

For:

Ersatzteilliste  
Spare parts list  
Liste des pièces de rechange  
Lista parti di ricambio  
Onderdelenlijst  
Lista de repuestos

# SK300-2 - 7739100138

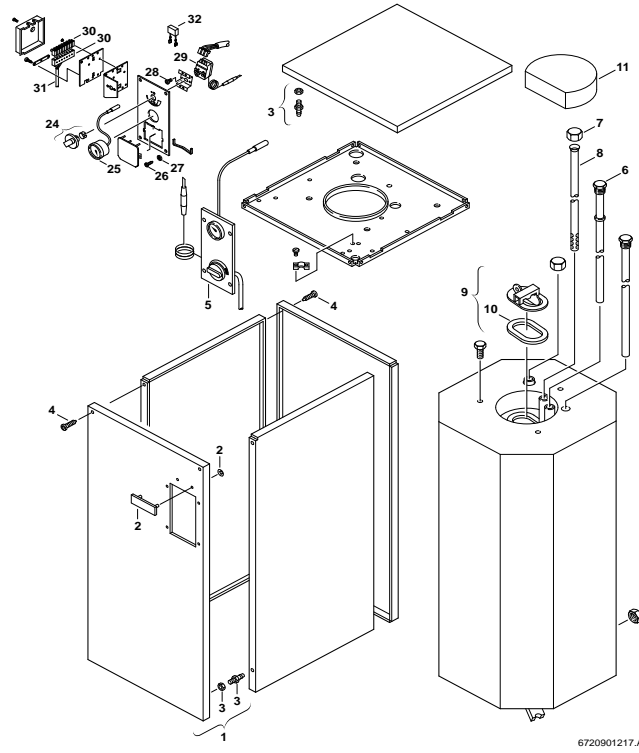

Pos	Bestell-Nr.	Bezeichnung	Description	Dénomination	Descrizione	Benaming	Descripción	PG
1	<b>8 735 402 977 0</b>	Vorderwand	Cover	Couvercle	Coperchio	Voordeksel	Tapa	44
2	<b>8 701 103 029 0</b>	Warenzeichen	Trade mark badge	Marquage	Targhetta	Fabrieksmerk	Marca	15
3	<b>8 719 918 772 0</b>	Befestigungssatz	Fixing set	Joint de fixation	Set di fissaggio	Bevestigingsset	Juego piezas de fijacion	23
4	<b>8 713 403 008 0</b>	Schraube (10x)	Screw	Vis (10x)	Vite (10x)	Schroef (10x)	Tornillo (10x)	11
6	<b>8 709 918 506 0</b>	Anode	Anode	Anode	Anodo	<small>ANODE SO 160-160/1-200-200/1-SK 180-300-</small>	Anodo	43
7	<b>8 733 304 999 0</b>	Kappe	Protective cap	Capot de protection	Sigillo	Beschermkap	Capuchón protector	20
10	<b>8 730 103 973 0</b>	Dichtung	Washer	Joint	Guarnizione	Pakkingring	Junta	31
11	<b>8 732 303 973 0</b>	Isolierung	Insulation	Isolation	Isolamento	Isolatie	Aislamiento	26

For:



**Ersatzteilliste**  
**Spare parts list**  
**Liste des pièces de rechange**  
**Lista parti di ricambio**  
**Onderdelenlijst**  
**Lista de repuestos**

# SK300-2Z - 7719000648

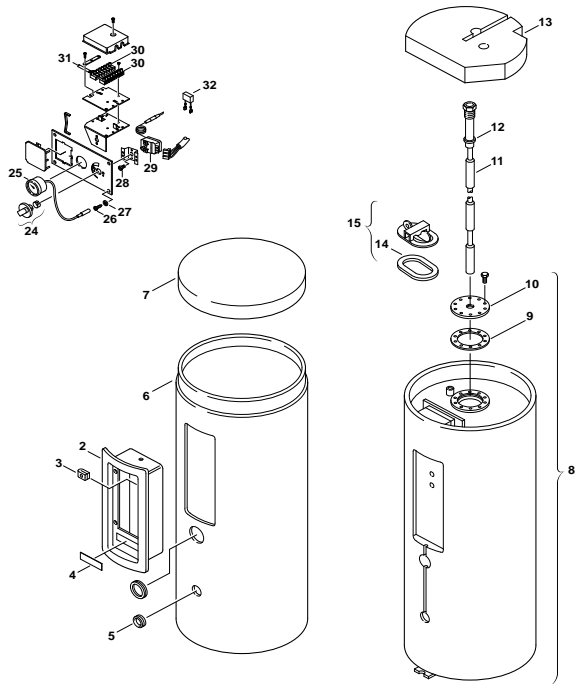

6720901218.AC/G

Pos	Bestell-Nr.	Bezeichnung	Description	Dénomination	Descrizione	Benaming	Descripción	PG
2	8 715 506 262 0	Rahmen	Frame	Cadre-support	Conice	Frame	Respaldo	42
3	8 713 309 026 0	Mutter (10x)	Nut	Ecrou (10x)	Dado (10x)	Moer (10x)	Tuerca (10x)	12
4	8 701 103 029 0	Warenzeichen	Trade mark badge	Marquage	Targhetta	Fabrieksmerk	Marca	15
5	8 710 506 080 0	Stopfen	Grommet	Bouchon	Coperchietto	Doorvoertule	Tapon	11
6	8 715 401 267 0	Mantel	Outer_case	Habillage	Mantello	Mantel	Carcasa	50
7	8 718 006 640 0	Haube	Hood	Capot	Carpot	Deksel	Capota	43
9	8 710 103 087 0	Dichtung	Washer	Joint	Guarnizione	<small>DICHTING FLENS SK 300/2Z (VANAF FD 744)</small>	Junta	24
10	8 715 503 098 0	Flansch	Connecting flange	Bride de raccordement	Flangia	FLENS SK 300-2ZB	Brida de conexión	36
11	8 709 918 506 0	Anode	Anode	Anode	Anodo	<small>ANODE SO 160-160/1-200-2001-SK 160-300-</small>	Anodo	43
12	8 710 103 086 0	Dichtscheibe (10x)	Washer (10x)	Joint (10x)	Guarnizione (10x)	<small>DICHTING ANODE VOOR SO 160</small>	Junta (10x)	22
13	8 718 006 398 0	Isolierung	Insulation	Isolation	Isolamento	Isolatie	Aislamiento	24
14	8 730 103 973 0	Dichtung	Washer	Joint	Guarnizione	Pakkingring	Junta	31
24	8 712 000 034 0	Drehknopf	Rotary handle	Bouton de réglage	Manopola	Regelknop	Botón rotativo	12
25	8 737 208 991 0	Thermometer	Thermometer	Thermomètre	Termometro	<small>THERMOMETER SO...SK...2Z-3Z - Z(W)...F</small>	Termómetro	37
26	8 713 403 008 0	Schraube (10x)	Screw	Vis (10x)	Vite (10x)	Schroef (10x)	Tornillo (10x)	11
27	2 916 030 006 0	Sicherungsscheibe (10x)	Retaining ring (10x)	Circlips (10x)	Rondella (10x)	<small>BORGRING UIT TTB 771900055P</small>	Arandela de seguridad (10x)	11
29	8 717 206 186 0	Temperaturregler	Flow thermostat	Thermostat	Thermostat	<small>AQUASTAAT M/WISSELKONTAKT SO 120-160-200</small>	Regulador de temperatura	36
30	8 711 006 046 0	Klemmleiste 24V	Terminal strip 24V	Bornier 24V	Cablaggio 24V	Klemmenstrook 24V	Regleta de bornes 24V	08
31	8 714 401 396 0	Kabel	Cable	Faisceau	Cablaggio	Kabel	Cable	23
32	8 717 301 017 0	Entstörkondensator	ENTSTÖRKONDENSATOR	Condensateur	Condensatore	<small>CONDENSATOR VOOR AQUASTAAT 8 737 206 974</small>	Condensador filtro	14

For:

Ersatzteilliste  
Spare parts list  
Liste des pièces de rechange  
Lista parti di ricambio  
Onderdelenlijst  
Lista de repuestos

**SK300-3ZB - 7719002877**

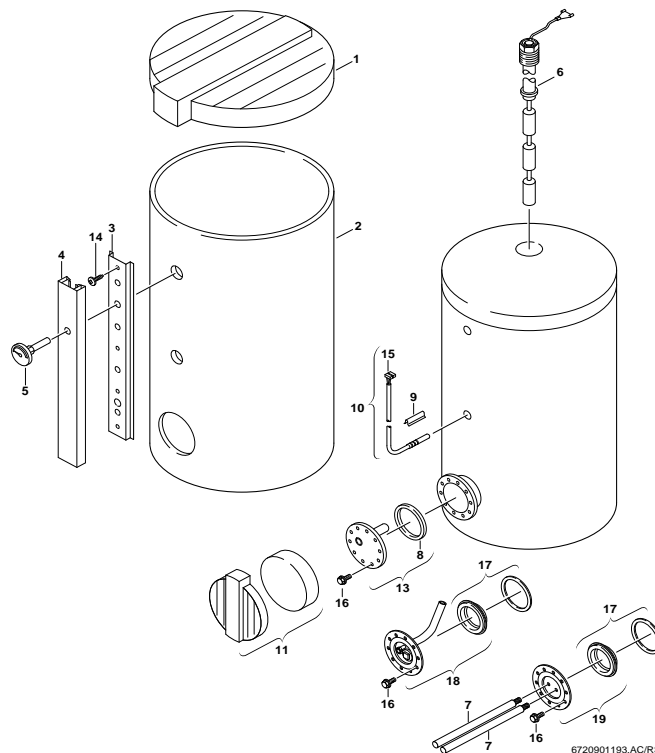

Pos	Bestell-Nr.	Bezeichnung	Description	Dénomination	Descrizione	Benaming	Descripción	PG
1	8 715 503 248 0	Haube grau	Hood grey	Capot gris	Carpot grigio	Deksel grijs	Tapa superior	42
1	8 715 503 437 0	Haube hellgrau	Hood light grey	Carpot gris clair	Coperchio grigio chiaro	Deksel lichtgrijs	Capota girar claro	42
2	8 715 401 302 0	Mantel weiß	Front shell white	Habillage blanc	Mantello bianco	MANTEL VOOR SK 300-3ZB (7719001369)	Carcasa blanco	47
3	8 718 005 563 0	Schiene	Frame	Structure	Telaio	Frame	Respaldo	31
4	8 715 503 251 0	Abdeckung grau	Covering sheet grey	Couvercle gris	Coperchio grigio	AFDEKPLAAT SK 300-3Z	Tapa	42
4	8 715 503 435 0	Abdeckung hellgrau	Covering sheet light grey	Couvercle gris clair	Coperchio grigio chiaro	Afdichting lichtgrijs	Chapa de protección girar claro	42
5	8 717 208 059 0	Thermometer	Thermometer	Thermomètre	Termometro	THERMOMETER SK 300-3ZB	Termómetro	38
6	8 709 918 666 0	Anode 1"	Anode 1"	Anode 1"	Anodo 1"	ANODE (KETTING) ST120/160-1E /SK 130-3Z	Anodo 1"	43
8	8 710 103 096 0	Dichtungs-Set 100x109D - 115/138Dx3 (1x)	Set of seals 100x109D - 115/138Dx3 (1x)	Jeu de joints 100x109D - 115/138Dx3 (1x)	Set guarnizioni 100x109D - 115/138Dx3	DICHTING FLENS SK - 22B/-3ZB (VANAF 070)	conjunto de juntas 100x109D - 115/138Dx3	23
8	8 710 103 145 0	Dichtring 190/245Dx3	Washer	Joint	Guarnizione	DICHTING FLENS SK 300-3ZB (TOT FD 07/03)	Anillo junta	30
9	8 714 606 021 0	Klemmfeder	Clamp spring	Ressort	Fermo	KLEIMVEER NTC SK120/A40/160-4ZB	Muelle de tecla	25
10	8 714 500 034 0	Sensor WW-NTC mit Aderendhülse 6m	Temperature sensor 6mm	SONDE DE TEMPERATURE 6mm	Sensore termometrico 6mm	Temperatuurvoeler 6mm	Sensor de temperatura 6mm	34
11	8 715 503 247 0	Abdeckung grau	Covering sheet grey	Couvercle gris	Coperchio grigio	Afdichting grijs	Chapa protección	40
11	8 715 503 436 0	Abdeckung hellgrau	Covering sheet light grey	Couvercle gris clair	Coperchio grigio chiaro	Afdichting lichtgrijs	Chapa de protección girar claro	40
13	8 715 503 252 0	Flansch	Connecting flange	Bride de raccordement	Flangia	FLENS SK 300-3ZB	Brida de conexión	47
14	8 713 403 008 0	Schraube (10x)	Screw	Vis (10x)	Vite (10x)	Schroef (10x)	Tornillo (10x)	11
15	8 711 006 060 0	Stecker	Plug	Connecteur	Spina	STEKKER NTC-VOELER ST...1ESK 300/ST 75	Anection	16
16	2 911 060 291 0	Schraube M10x25 (10x)	Screw M10x25 (10x)	Vis M10x25 (10x)	Vite M10x25 (10x)	Schroef M10x25 (10x)	Tornillo M10x25 (10x)	18
16	2 911 060 342 0	Schraube M12x30 (10x)	Screw M12x30 (10x)	Vis M12x30 (10x)	Vite M12x30 (10x)	Schroef M12x30 (10x)	Tornillo M12x30 (10x)	16
17	8 710 103 096 0	Dichtungs-Set 100x109D - 115/138Dx3 (1x)	Set of seals 100x109D - 115/138Dx3 (1x)	Jeu de joints 100x109D - 115/138Dx3 (1x)	Set guarnizioni 100x109D - 115/138Dx3	DICHTING FLENS SK - 22B/-3ZB (VANAF 070)	conjunto de juntas 100x109D - 115/138Dx3	23
18	8 715 503 170 0	Flansch mit Tauchrohr kpl.	Connecting flange	Bride de raccordement	Flangia	FLENS + DICHTING SK - 3ZB	Conjunto brida y junta SK500	40
	8 718 220 039 0	Hülse 1 1/4"	Sleeve 1 1/4"	Douille 1 1/4"	Bocchetta 1 1/4"	Bus 1 1/4"	Manguito 1 1/4"	09

For:

Ersatzteilliste  
Spare parts list  
Liste des pièces de rechange  
Lista parti di ricambio  
Onderdelenlijst  
Lista de repuestos

## SK300-3ZB/C2 - 7719002122

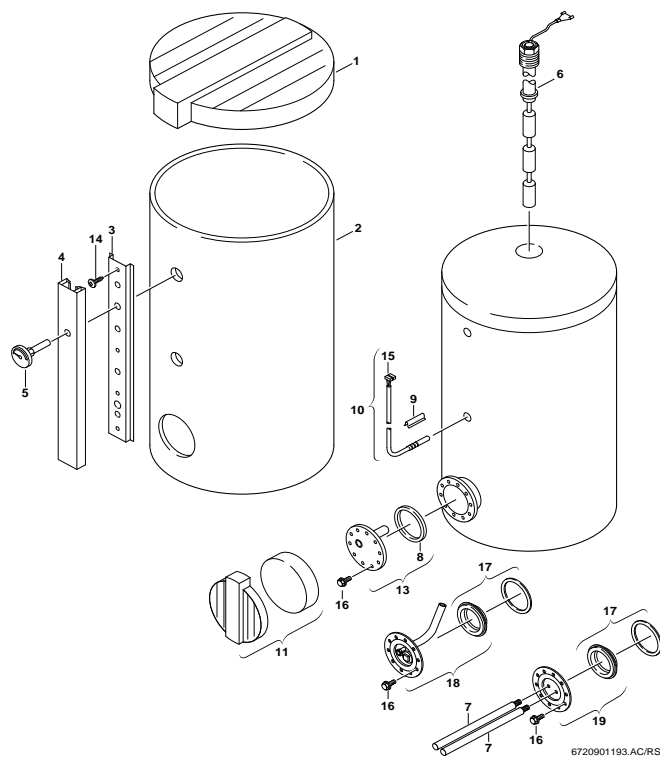

Pos	Bestell-Nr.	Bezeichnung	Description	Dénomination	Descrizione	Benaming	Descripción	PG
1	8 715 503 418 0	Haube silbergrau	Hood silver grey	Carpot argent gris	Coperchio argentato grigio	Deksel zilvergrijs	Capota plata girar	42
2	8 715 401 390 0	Mantel silbergrau	Front shell silver grey	Habillage argent gris	Mantello argentato grigio	Mantel zilver grijs	Carcasa plata girar	47
3	8 718 005 563 0	Schiene	Frame	Structure	Telaio	Frame	Respaldo	31
4	8 715 503 431 0	Abdeckung gelb	Covering sheet yellow	Couvercle jaune	Coperchio giallo	Afdichting geel	Chapa de protección amarillo	42
5	8 717 208 059 0	Thermometer	Thermometer	Thermomètre	Termometro	THERMOMETER SK 300-3ZB	Termómetro	38
6	8 709 918 666 0	Anode 1"	Anode 1"	Anode 1"	Anodo 1"	ANODE (KETTING) ST120/160-1E./SK 130-3Z	Anodo 1"	43
8	8 710 103 096 0	Dichtungs-Set 100x109D - 115/138Dx3 (1x)	Set of seals 100x109D - 115/138Dx3 (1x)	Jeu de joints 100x109D - 115/138Dx3 (1x)	Set guarnizioni 100x109D - 115/138Dx3	DICHTING FLENS SK...2ZB-3ZB (VANAF 07/0)	conjunto de juntas 100x109D - 115/138Dx3	23
8	8 710 103 145 0	Dichtring 190/245Dx3	Washer	Joint	Guarnizione	DICHTING FLENS SK 300-3ZB (TOT FD 07/03)	Anillo junta	30
9	8 714 606 021 0	Klemmfeder	Clamp spring	Ressort	Fermo	KLEMVEER NTC SK120/140/160-4ZB	Muelle de tecla	25
10	8 714 500 034 0	Sensor WW-NTC mit Aderendhülse 6m	Temperature sensor 6mm	SONDE DE TEMPERATURE 6mm	Sensore termometrico 6mm	Temperatuurvoeler 6mm	Sensor de temperatura 6mm	34
11	8 715 503 423 0	Abdeckung silbergrau	Covering sheet silver grey	Couvercle argent gris	Coperchio argentato grigio	Afdichting zilver grijs	Chapa de protección plata girar	40
13	8 715 503 252 0	Flansch	Connecting flange	Bride de raccordement	Flangia	FLENS SK 300-3ZB	Brida de conexión	47
14	8 713 403 008 0	Schraube (10x)	Screw	Vis (10x)	Vite (10x)	Schroef (10x)	Tornillo (10x)	11
15	8 711 006 060 0	Stecker	Plug	Connecteur	Spina	STECKER NTC-VOELER ST...1E/SK 300/ST 75	Aneccion	16
16	2 911 060 291 0	Schraube M10x25 (10x)	Screw M10x25 (10x)	Vis M10x25 (10x)	Vite M10x25 (10x)	Schroef M10x25 (10x)	Tornillo M10x25 (10x)	18
16	2 911 060 342 0	Schraube M12x30 (10x)	Screw M12x30 (10x)	Vis M12x30 (10x)	Vite M12x30 (10x)	Schroef M12x30 (10x)	Tornillo M12x30 (10x)	16
17	8 710 103 096 0	Dichtungs-Set 100x109D - 115/138Dx3 (1x)	Set of seals 100x109D - 115/138Dx3 (1x)	Jeu de joints 100x109D - 115/138Dx3 (1x)	Set guarnizioni 100x109D - 115/138Dx3	DICHTING FLENS SK...2ZB-3ZB (VANAF 07/0)	conjunto de juntas 100x109D - 115/138Dx3	23
18	8 715 503 170 0	Flansch mit Tauchrohr kpl.	Connecting flange	Bride de raccordement	Flangia	FLENS + DICHTING SK - 3ZB	Conjunto brida y junta SK500	40
	8 718 220 039 0	Hülse 1 1/4"	Sleeve 1 1/4"	Douille 1 1/4"	Bocchetta 1 1/4"	Bus 1 1/4"	Manguito 1 1/4"	09

For:

Ersatzteilliste  
Spare parts list  
Liste des pièces de rechange  
Lista parti di ricambio  
Onderdelenlijst  
Lista de repuestos

## SK300-3ZBS0400 - 7719001583

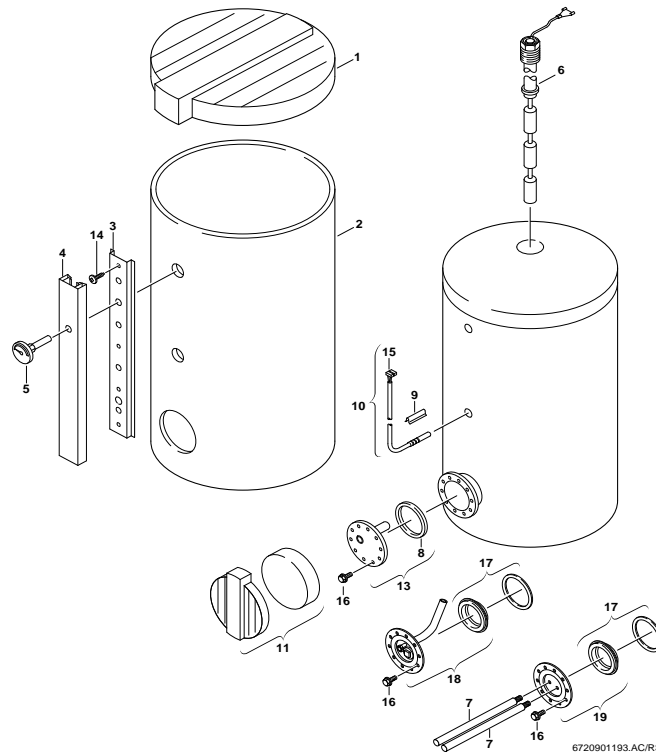

Pos	Bestell-Nr.	Bezeichnung	Description	Dénomination	Descrizione	Benaming	Descripción	PG
1	8 715 503 437 0	Haube hellgrau	Hood light grey	Carpot gris clair	Coperchio grigio chiaro	Deksel lichtgrijs	Capota girar claro	42
2	8 715 401 302 0	Mantel weiß	Front shell white	Habillage blanc	Mantello bianco	MANTEL VOOR SK 300-3ZB (7719001369)	Carcasa blanco	47
3	8 718 005 563 0	Schiene	Frame	Structure	Telaio	Frame	Respaldo	31
4	8 715 503 435 0	Abdeckung hellgrau	Covering sheet light grey	Couvercle gris clair	Coperchio grigio chiaro	Afdichting lichtgrijs	Chapa de protección girar claro	42
5	8 717 208 059 0	Thermometer	Thermometer	Thermomètre	Termometro	THERMOMETER SK 300-3ZB	Termómetro	38
6	8 709 918 666 0	Anode 1"	Anode 1"	Anode 1"	Anodo 1"	ANODE (KETTING) ST120/160-1E /SK 130-3Z	Anodo 1"	43
8	8 710 103 096 0	Dichtungs-Set 100x109D - 115/138Dx3 (1x)	Set of seals 100x109D - 115/138Dx3 (1x)	Jeu de joints 100x109D - 115/138Dx3 (1x)	Set guarnizioni 100x109D - 115/138Dx3	DICHTING FLENS SK...22B-3ZB (VANAF 07/0)	conjunto de juntas 100x109D - 115/138Dx3	23
8	8 710 103 145 0	Dichtring 190/245Dx3	Washer	Joint	Guarnizione	DICHTING FLENS SK 300-3ZB (TOT FD 07/03)	Anillo junta	30
9	8 714 606 021 0	Klemmfeder	Clamp spring	Ressort	Fermo	KLEMVEER NTC SK120/140/160-4ZB	Muelle de tecla	25
10	8 714 500 034 0	Sensor WW-NTC mit Aderendhülse 6mm	Temperature sensor 6mm	SONDE DE TEMPERATURE 6mm	Sensore termometrico 6mm	Temperatuurvoeler 6mm	Sensor de temperatura 6mm	34
11	8 715 503 436 0	Abdeckung hellgrau	Covering sheet light grey	Couvercle gris clair	Coperchio grigio chiaro	Afdichting lichtgrijs	Chapa de protección girar claro	40
14	8 713 403 008 0	Schraube (10x)	Screw	Vis (10x)	Vite (10x)	Schroef (10x)	Tornillo (10x)	11
15	8 711 006 060 0	Stecker	Plug	Connecteur	Spina	STEKKER NTC-VOELER ST...1E/SK 300/ST 75	Anection	16
16	2 911 060 291 0	Schraube M10x25 (10x)	Screw M10x25 (10x)	Vis M10x25 (10x)	Vite M10x25 (10x)	Schroef M10x25 (10x)	Tornillo M10x25 (10x)	18
16	2 911 060 342 0	Schraube M12x30 (10x)	Screw M12x30 (10x)	Vis M12x30 (10x)	Vite M12x30 (10x)	Schroef M12x30 (10x)	Tornillo M12x30 (10x)	16
17	8 710 103 096 0	Dichtungs-Set 100x109D - 115/138Dx3 (1x)	Set of seals 100x109D - 115/138Dx3 (1x)	Jeu de joints 100x109D - 115/138Dx3 (1x)	Set guarnizioni 100x109D - 115/138Dx3	DICHTING FLENS SK...22B-3ZB (VANAF 07/0)	conjunto de juntas 100x109D - 115/138Dx3	23
18	8 715 503 170 0	Flansch mit Tauchrohr kpl.	Connecting flange	Bride de raccordement	Flangia	FLENS + DICHTING SK - 3ZB	Conjunto brida y junta SK500	40
	8 718 220 039 0	Hülse 1 1/4"	Sleeve 1 1/4"	Douille 1 1/4"	Bocchetta 1 1/4"	Bus 1 1/4"	Manguito 1 1/4"	09

For:

Ersatzteilliste  
Spare parts list  
Liste des pièces de rechange  
Lista parti di ricambio  
Onderdelenlijst  
Lista de repuestos

**SK300-3ZBS3500 - 7719001463**

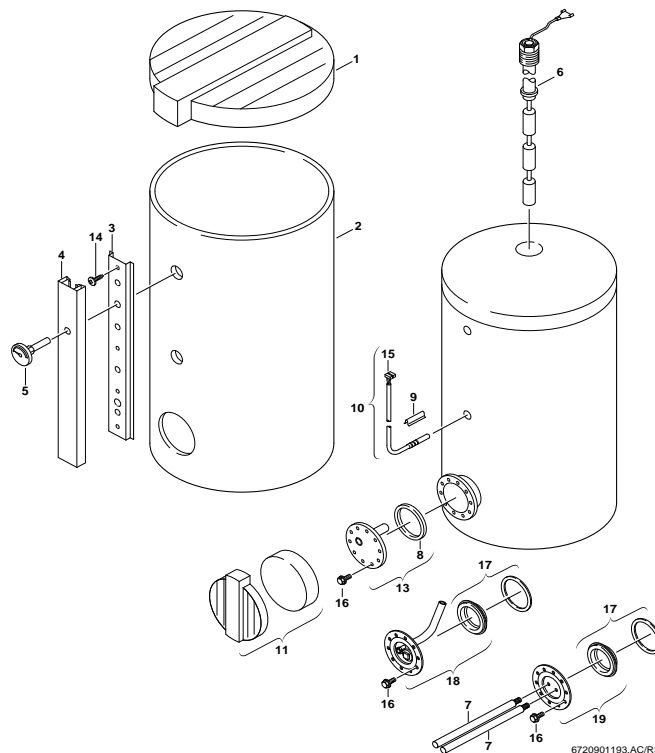

Pos	Bestell-Nr.	Bezeichnung	Description	Dénomination	Descrizione	Benaming	Descripción	PG
1	8 715 503 248 0	Haube grau	Hood grey	Capot gris	Carpot grigio	Deksel grijs	Tapa superior	42
1	8 715 503 437 0	Haube hellgrau	Hood light grey	Carpot gris clair	Coperchio grigio chiaro	Deksel lichtgrijs	Capota girar claro	42
2	8 715 401 302 0	Mantel weiß	Front shell white	Habillage blanc	Mantello bianco	MANTEL VOOR SK 300-3ZB (7719001369)	Carcasa blanco	47
3	8 718 005 563 0	Schiene	Frame	Structure	Telaio	Frame	Respaldo	31
4	8 715 503 251 0	Abdeckung grau	Covering sheet grey	Couvercle gris	Coperchio grigio	AFDEKPLAAT SK 300-3Z	Tapa	42
4	8 715 503 435 0	Abdeckung hellgrau	Covering sheet light grey	Couvercle gris clair	Coperchio grigio chiaro	Afdichting lichtgrijs	Chapa de protección girar claro	42
5	8 717 208 059 0	Thermometer	Thermometer	Thermomètre	Termometro	THERMOMETER SK 300-3ZB	Termómetro	38
6	8 709 918 666 0	Anode 1"	Anode 1"	Anode 1"	Anodo 1"	ANODE (KETTING) ST120/160-1E /SK 130-3Z	Anodo 1"	43
8	8 710 103 096 0	Dichtungs-Set 100x109D - 115/138Dx3 (1x)	Set of seals 100x109D - 115/138Dx3 (1x)	Jeu de joints 100x109D - 115/138Dx3 (1x)	Set guarnizioni 100x109D - 115/138Dx3	DICHTING FLENS SK - 22B/-3ZB (VANAF 070)	conjunto de juntas 100x109D - 115/138Dx3	23
8	8 710 103 145 0	Dichtring 190/245Dx3	Washer	Joint	Guarnizione	DICHTING FLENS SK 300-3ZB (TOT FD 07/03)	Anillo junta	30
9	8 714 606 021 0	Klemmfeder	Clamp spring	Ressort	Fermo	KLEM/VEER NTC SK120/A40/160-4ZB	Muelle de tecla	25
10	8 714 500 034 0	Sensor WW-NTC mit Aderendhülse 6m	Temperature sensor 6mm	SONDE DE TEMPERATURE 6mm	Sensore termometrico 6mm	Temperatuurvoeler 6mm	Sensor de temperatura 6mm	34
11	8 715 503 247 0	Abdeckung grau	Covering sheet grey	Couvercle gris	Coperchio grigio	Afdichting grijs	Chapa protección	40
11	8 715 503 436 0	Abdeckung hellgrau	Covering sheet light grey	Couvercle gris clair	Coperchio grigio chiaro	Afdichting lichtgrijs	Chapa de protección girar claro	40
13	8 715 503 252 0	Flansch	Connecting flange	Bride de raccordement	Flangia	FLENS SK 300-3ZB	Brida de conexión	47
14	8 713 403 008 0	Schraube (10x)	Screw	Vis (10x)	Vite (10x)	Schroef (10x)	Tornillo (10x)	11
15	8 711 006 060 0	Stecker	Plug	Connecteur	Spina	STEKKER NTC-VOELER ST...1ESK 300/ST 75	Anection	16
16	2 911 060 291 0	Schraube M10x25 (10x)	Screw M10x25 (10x)	Vis M10x25 (10x)	Vite M10x25 (10x)	Schroef M10x25 (10x)	Tornillo M10x25 (10x)	18
16	2 911 060 342 0	Schraube M12x30 (10x)	Screw M12x30 (10x)	Vis M12x30 (10x)	Vite M12x30 (10x)	Schroef M12x30 (10x)	Tornillo M12x30 (10x)	16
17	8 710 103 096 0	Dichtungs-Set 100x109D - 115/138Dx3 (1x)	Set of seals 100x109D - 115/138Dx3 (1x)	Jeu de joints 100x109D - 115/138Dx3 (1x)	Set guarnizioni 100x109D - 115/138Dx3	DICHTING FLENS SK - 22B/-3ZB (VANAF 070)	conjunto de juntas 100x109D - 115/138Dx3	23
18	8 715 503 170 0	Flansch mit Tauchrohr kpl.	Connecting flange	Bride de raccordement	Flangia	FLENS + DICHTING SK - 3ZB	Conjunto brida y junta SK500	40
	7 709 500 052	Überdruckventil 1/2"3/4" 10 bar	VÁLVULA SEG. 1/2"3/4" 10 bar	VÁLVULA SEG. 1/2"3/4" 10 bar	Valvola di sovrappressione 1/2"3/4" 10 bar	Overdrukvelligheid 1/2"3/4" 10 bar	VÁLVULA SEG. 1/2"3/4" 10 bar	
	7 709 500 080	Rückschlagventil 1"	Non-return valve 1"	Soupape de non-retour 1"	Valvola di non ritorno 1"	Terugslagklep 1"	válvula de retención 1"	
	8 718 220 039 0	Hülse 1 1/4"	Sleeve 1 1/4"	Douille 1 1/4"	Bocchetta 1 1/4"	Bus 1 1/4"	Manguito 1 1/4"	09

For:

**Ersatzteilliste**  
**Spare parts list**  
**Liste des pièces de rechange**  
**Lista parti di ricambio**  
**Onderdelenlijst**  
**Lista de repuestos**

## SK400-1SOLAR - 7739300910

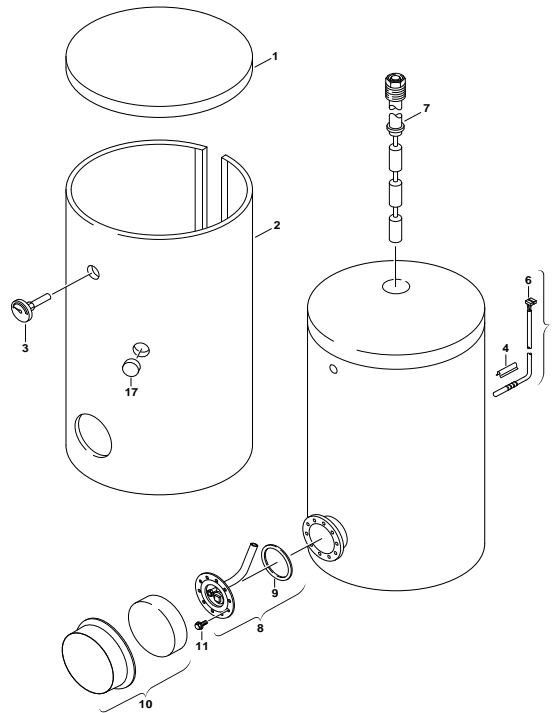

6720901194.AC/G

Pos	Bestell-Nr.	Bezeichnung	Description	Dénomination	Descrizione	Benaming	Descripción	PG
1	8 715 503 345 0	Haube hellgrau	Hood light grey	Carpot gris clair	Coperchio grigio chiaro	Deksel lichtgrijs	Capota gris claro	41
2	8 715 401 303 0	Mantel weiß	Shell white	HABILLAGE BLANC SH370	Mantello bianco	Mantel wit	Carcasa blanco	51
3	8 717 208 050 0	Thermometer	Thermometer	Thermomètre	Termometro	Thermometer	Termómetro	31
4	8 714 606 021 0	Klemmfeder	Clamp spring	Ressort	Fermo	KLEMVEER NTC SK120/140/160-4ZB	Muelle de tecla	25
5	8 714 500 034 0	Sensor WW-NTC mit Aderendhülse 6mm	Temperature sensor 6mm	SONDE DE TEMPERATURE 6mm	Sensore termometrico 6mm	Temperatuurvoeler 6mm	Sensor de temperatura 6mm	34
6	8 711 006 060 0	Stecker	Plug	Connecteur	Spina	STEKKER NTC-VOELER ST...1ESK 300ST 75	Anection	16
7	8 709 918 506 0	Anode	Anode	Anode	Anodo	ANODE SO 160-160/1-200-200/1-SK 180-300-	Anodo	43
7	8 709 918 666 0	Anode 1"	Anode 1"	Anode 1"	Anodo 1"	ANODE (KETTING) ST120/160-1E/SK 130-3Z	Anodo 1"	43
8	8 715 503 170 0	Flansch mit Tauchrohr kpl.	Connecting flange	Bride de raccordement	Flangia	FLENS + DICHTING SK - 3ZB	Conjunto brida y junta SK500	40
9	8 710 103 096 0	Dichtungs-Set 100x109D - 115/138Dx3 (1x)	Set of seals 100x109D - 115/138Dx3 (1x)	Jeu de joints 100x109D - 115/138Dx3 (1x)	Set guarnizioni 100x109D - 115/138Dx3	DICHTING FLENS SK...2ZB-3ZB (VANAF 070)	conjunto de juntas 100x109D - 115/138Dx3	23
10	8 715 503 346 0	Abdeckung hellgrau	Covering sheet light grey	Couvercle gris clair	Coperchio grigio chiaro	DEKSEL SK 300-1/400-1/500-1 SOLAR	Chapa de protección girar claro	33
11	2 911 060 291 0	Schraube M10x25 (10x)	Screw M10x25 (10x)	Vis M10x25 (10x)	Vite M10x25 (10x)	Schroef M10x25 (10x)	Tornillo M10x25 (10x)	18
11	2 911 060 342 0	Schraube M12x30 (10x)	Screw M12x30 (10x)	Vis M12x30 (10x)	Vite M12x30 (10x)	Schroef M12x30 (10x)	Tornillo M12x30 (10x)	16
17	8 715 503 239 0	Isolierung	Insulation	Bouchon	Isolamento	ISOLATIE SK 300-1 SOLAR (7719001929)	Aislamiento	23
	8 718 220 038 0	Hülse 1"	Sleeve 1"	Douille 1"	Bocchetta 1"	ISOLATIE DEKSEL SK 300-1/400-1/500-1 SOLAR	Manguito 1"	09
For:								

Ersatzteilliste  
Spare parts list  
Liste des pièces de rechange  
Lista parti di ricambio  
Onderdelenlijst  
Lista de repuestos

# SK400-3ZB S2800 - 7719002878

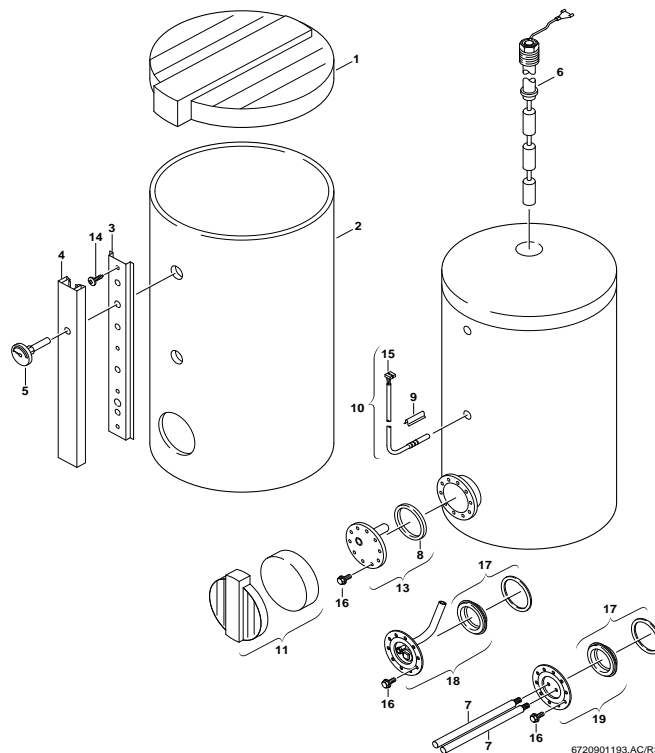

Pos	Bestell-Nr.	Bezeichnung	Description	Dénomination	Descrizione	Benaming	Descripción	PG
1	8 715 503 248 0	Haube grau	Hood grey	Capot gris	Carpot grigio	Deksel grijs	Tapa superior	42
1	8 715 503 437 0	Haube hellgrau	Hood light grey	Carpot gris clair	Coperchio grigio chiaro	Deksel lichtgrijs	Capota girar claro	42
2	8 715 401 303 0	Mantel weiß	Shell white	HABILLAGE BLANC SH370	Mantello bianco	Mantel wit	Carcasa blanco	51
3	8 718 005 564 0	Schiene	Frame	Structure	Telaio	Frame	Respaldo	32
4	8 715 503 251 0	Abdeckung grau	Covering sheet grey	Couvercle gris	Coperchio grigio	AFDEKPLAAT SK 300-3Z	Tapa	42
4	8 715 503 435 0	Abdeckung hellgrau	Covering sheet light grey	Couvercle gris clair	Coperchio grigio chiaro	Afdichting lichtgrijs	Chapa de protección girar claro	42
5	8 717 208 059 0	Thermometer	Thermometer	Thermomètre	Termometro	THERMOMETER SK 300-3ZB	Termómetro	38
6	8 709 918 666 0	Anode 1"	Anode 1"	Anode 1"	Anodo 1"	ANODE (KETTING) ST120/160-1E /SK 130-3Z	Anodo 1"	43
8	8 710 103 096 0	Dichtungs-Set 100x109D - 115/138Dx3 (1x)	Set of seals 100x109D - 115/138Dx3 (1x)	Jeu de joints 100x109D - 115/138Dx3 (1x)	Set guarnizioni 100x109D - 115/138Dx3	DICHTING FLENS SK - 2ZB-3ZB (VANAF 070)	conjunto de juntas 100x109D - 115/138Dx3	23
8	8 710 103 145 0	Dichtring 190/245Dx3	Washer	Joint	Guarnizione	DICHTING FLENS SK 300-3ZB (TOT FD 07/03)	Anillo junta	30
9	8 714 606 021 0	Klemmfeder	Clamp spring	Ressort	Fermo	KLEM/VEER NTC SK120/A40/160-4ZB	Muelle de tecla	25
10	8 714 500 034 0	Sensor WW-NTC mit Aderendhülse 6m	Temperature sensor 6mm	SONDE DE TEMPERATURE 6mm	Sensore termometrico 6mm	Temperatuurvoeler 6mm	Sensor de temperatura 6mm	34
11	8 715 503 247 0	Abdeckung grau	Covering sheet grey	Couvercle gris	Coperchio grigio	Afdichting grijs	Chapa protección	40
11	8 715 503 436 0	Abdeckung hellgrau	Covering sheet light grey	Couvercle gris clair	Coperchio grigio chiaro	Afdichting lichtgrijs	Chapa de protección girar claro	40
13	8 715 503 252 0	Flansch	Connecting flange	Bride de raccordement	Flangia	FLENS SK 300-3ZB	Brida de conexión	47
14	8 713 403 008 0	Schraube (10x)	Screw	Vis (10x)	Vite (10x)	Schroef (10x)	Tornillo (10x)	11
15	8 711 006 060 0	Stecker	Plug	Connecteur	Spina	STEKKER NTC-VOELER ST...1ESK 300/ST 75	Anection	16
16	2 911 060 291 0	Schraube M10x25 (10x)	Screw M10x25 (10x)	Vis M10x25 (10x)	Vite M10x25 (10x)	Schroef M10x25 (10x)	Tornillo M10x25 (10x)	18
16	2 911 060 342 0	Schraube M12x30 (10x)	Screw M12x30 (10x)	Vis M12x30 (10x)	Vite M12x30 (10x)	Schroef M12x30 (10x)	Tornillo M12x30 (10x)	16
17	8 710 103 096 0	Dichtungs-Set 100x109D - 115/138Dx3 (1x)	Set of seals 100x109D - 115/138Dx3 (1x)	Jeu de joints 100x109D - 115/138Dx3 (1x)	Set guarnizioni 100x109D - 115/138Dx3	DICHTING FLENS SK - 2ZB-3ZB (VANAF 070)	conjunto de juntas 100x109D - 115/138Dx3	23
18	8 715 503 170 0	Flansch mit Tauchrohr kpl.	Connecting flange	Bride de raccordement	Flangia	FLENS + DICHTING SK - 3ZB	Conjunto brida y junta SK500	40
	8 718 220 039 0	Hülse 1 1/4"	Sleeve 1 1/4"	Douille 1 1/4"	Bocchetta 1 1/4"	Bus 1 1/4"	Manguito 1 1/4"	09

For:

Ersatzteilliste  
 Spare parts list  
 Liste des pièces de rechange  
 Lista parti di ricambio  
 Onderdelenlijst  
 Lista de repuestos

## SK400-3ZB/C2 - 7719002123

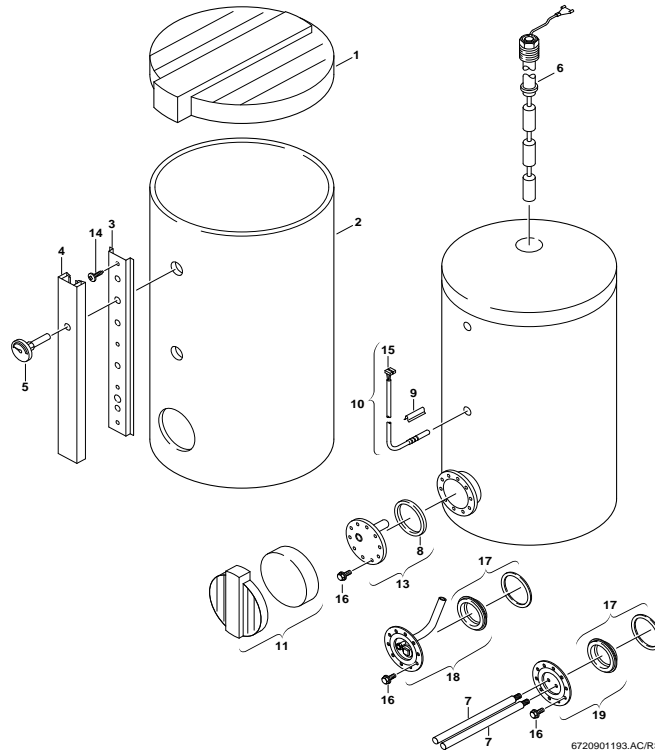

Pos	Bestell-Nr.	Bezeichnung	Description	Dénomination	Descrizione	Benaming	Descripción	PG
1	8 715 503 418 0	Haube silbergrau	Hood silver grey	Carpot argent gris	Coperchio argentato grigio	Deksel zilvergrijs	Capota plata girar	42
2	8 715 401 391 0	Mantel silbergrau	Front shell silver grey	Habillage argent gris	Mantello argentato grigio	Mantel zilver grijs	Carcasa plata girar	51
3	8 718 005 564 0	Schiene	Frame	Structure	Telaio	Frame	Respaldo	32
4	8 715 503 431 0	Abdeckung gelb	Covering sheet yellow	Couvercle jaune	Coperchio giallo	Afdichting geel	Chapa de protección amarillo	42
5	8 717 208 059 0	Thermometer	Thermometer	Thermomètre	Termometro	THERMOMETER SK 300-3ZB	Termómetro	38
6	8 709 918 666 0	Anode 1"	Anode 1"	Anode 1"	Anodo 1"	ANODE (KETTING) ST120/160-1E /SK 130-3Z	Anodo 1"	43
8	8 710 103 096 0	Dichtungs-Set 100x109D - 115/138Dx3 (1x)	Set of seals 100x109D - 115/138Dx3 (1x)	Jeu de joints 100x109D - 115/138Dx3 (1x)	Set guarnizioni 100x109D - 115/138Dx3	DICHTING FLENS SK...22B-3ZB (VANAF 070)	conjunto de juntas 100x109D - 115/138Dx3	23
8	8 710 103 145 0	Dichtring 190/245Dx3	Washer	Joint	Guarnizione	DICHTING FLENS SK 300-3ZB (TOT FD 0703)	Anillo junta	30
9	8 714 606 021 0	Klemmfeder	Clamp spring	Ressort	Fermo	KLEMVEER NTC SK120/140/160-42B	Muelle de tecla	25
10	8 714 500 034 0	Sensor WW-NTC mit Aderendhülse 6m	Temperature sensor 6mm	SONDE DE TEMPERATURE 6mm	Sensore termometrico 6mm	Temperatuurvoeler 6mm	Sensor de temperatura 6mm	34
11	8 715 503 423 0	Abdeckung silbergrau	Covering sheet silver grey	Couvercle argent gris	Coperchio argentato grigio	Afdichting zilver grijs	Chapa de protección plata girar	40
13	8 715 503 252 0	Flansch	Connecting flange	Bride de raccordement	Flangia	FLENS SK 300-3ZB	Brida de conexión	47
14	8 713 403 008 0	Schraube (10x)	Screw	Vis (10x)	Vite (10x)	Schroef (10x)	Tornillo (10x)	11
15	8 711 006 060 0	Stecker	Plug	Connecteur	Spina	STECKER NTC-VOELER ST...1E/SK 300/ST 75	Anection	16
16	2 911 060 291 0	Schraube M10x25 (10x)	Screw M10x25 (10x)	Vis M10x25 (10x)	Vite M10x25 (10x)	Schroef M10x25 (10x)	Tornillo M10x25 (10x)	18
16	2 911 060 342 0	Schraube M12x30 (10x)	Screw M12x30 (10x)	Vis M12x30 (10x)	Vite M12x30 (10x)	Schroef M12x30 (10x)	Tornillo M12x30 (10x)	16
17	8 710 103 096 0	Dichtungs-Set 100x109D - 115/138Dx3 (1x)	Set of seals 100x109D - 115/138Dx3 (1x)	Jeu de joints 100x109D - 115/138Dx3 (1x)	Set guarnizioni 100x109D - 115/138Dx3	DICHTING FLENS SK...22B-3ZB (VANAF 070)	conjunto de juntas 100x109D - 115/138Dx3	23
18	8 715 503 170 0	Flansch mit Tauchrohr kpl.	Connecting flange	Bride de raccordement	Flangia	FLENS + DICHTING SK - 3ZB	Conjunto brida y junta SK500	40
	8 718 220 039 0	Hülse 1 1/4"	Sleeve 1 1/4"	Douille 1 1/4"	Bocchetta 1 1/4"	Bus 1 1/4"	Manguito 1 1/4"	09

For:



Ersatzteilliste  
Spare parts list  
Liste des pièces de rechange  
Lista parti di ricambio  
Onderdelenlijst  
Lista de repuestos

**SK400-3ZBS3500 - 7719001464**

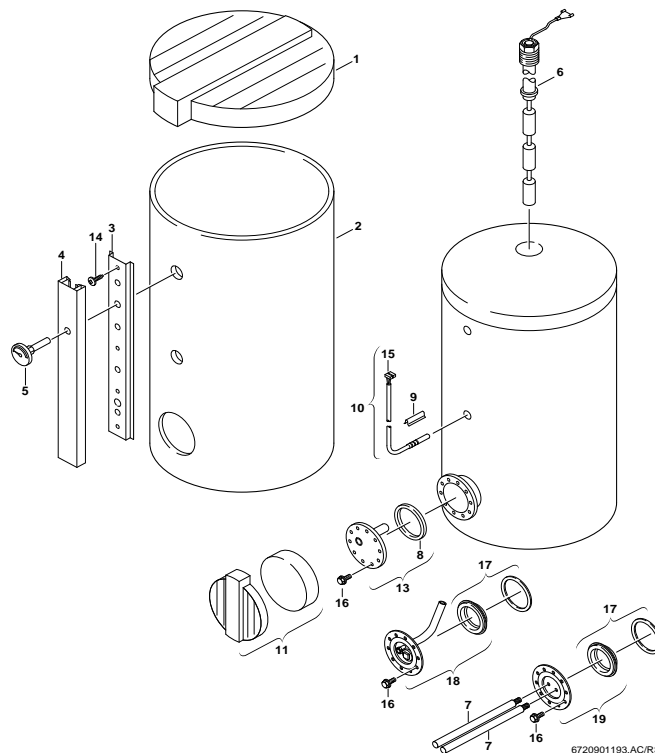

Pos	Bestell-Nr.	Bezeichnung	Description	Dénomination	Descrizione	Benaming	Descripción	PG
1	8 715 503 248 0	Haube grau	Hood grey	Capot gris	Carpot grigio	Deksel grijs	Tapa superior	42
1	8 715 503 437 0	Haube hellgrau	Hood light grey	Carpot gris clair	Coperchio grigio chiaro	Deksel lichtgrijs	Capota girar claro	42
2	8 715 401 303 0	Mantel weiß	Shell white	HABILLAGE BLANC SH370	Mantello bianco	Mantel wit	Carcasa blanco	51
3	8 718 005 564 0	Schiene	Frame	Structure	Telaio	Frame	Respaldo	32
4	8 715 503 251 0	Abdeckung grau	Covering sheet grey	Couvercle gris	Coperchio grigio	AFDEKPLAAT SK 300-3Z	Tapa	42
4	8 715 503 435 0	Abdeckung hellgrau	Covering sheet light grey	Couvercle gris clair	Coperchio grigio chiaro	Afdichting lichtgrijs	Chapa de protección girar claro	42
5	8 717 208 059 0	Thermometer	Thermometer	Thermomètre	Termometro	THERMOMETER SK 300-3ZB	Termómetro	38
6	8 709 918 666 0	Anode 1"	Anode 1"	Anode 1"	Anodo 1"	ANODE (KETTING) ST120/160-1E /SK 130-3Z	Anodo 1"	43
8	8 710 103 096 0	Dichtungs-Set 100x109D - 115/138Dx3 (1x)	Set of seals 100x109D - 115/138Dx3 (1x)	Jeu de joints 100x109D - 115/138Dx3 (1x)	Set guarnizioni 100x109D - 115/138Dx3	DICHTING FLENS SK...2ZB-3ZB (VANAF 070)	conjunto de juntas 100x109D - 115/138Dx3	23
8	8 710 103 145 0	Dichtring 190/245Dx3	Washer	Joint	Guarnizione	DICHTING FLENS SK 300-3ZB (TOT FD 07/03)	Anillo junta	30
9	8 714 606 021 0	Klemmfeder	Clamp spring	Ressort	Fermo	KLEM/VEER NTC SK120/A40/160-4ZB	Muelle de tecla	25
10	8 714 500 034 0	Sensor WW-NTC mit Aderendhülse 6m	Temperature sensor 6mm	SONDE DE TEMPERATURE 6mm	Sensore termometrico 6mm	Temperatuurvoeler 6mm	Sensor de temperatura 6mm	34
11	8 715 503 247 0	Abdeckung grau	Covering sheet grey	Couvercle gris	Coperchio grigio	Afdichting grijs	Chapa protección	40
11	8 715 503 436 0	Abdeckung hellgrau	Covering sheet light grey	Couvercle gris clair	Coperchio grigio chiaro	Afdichting lichtgrijs	Chapa de protección girar claro	40
13	8 715 503 252 0	Flansch	Connecting flange	Bride de raccordement	Flangia	FLENS SK 300-3ZB	Brida de conexión	47
14	8 713 403 008 0	Schraube (10x)	Screw	Vis (10x)	Vite (10x)	Schroef (10x)	Tornillo (10x)	11
15	8 711 006 060 0	Stecker	Plug	Connecteur	Spina	STEKKER NTC-VOELER ST...1ESK 300/ST 75	Anection	16
16	2 911 060 291 0	Schraube M10x25 (10x)	Screw M10x25 (10x)	Vis M10x25 (10x)	Vite M10x25 (10x)	Schroef M10x25 (10x)	Tornillo M10x25 (10x)	18
16	2 911 060 342 0	Schraube M12x30 (10x)	Screw M12x30 (10x)	Vis M12x30 (10x)	Vite M12x30 (10x)	Schroef M12x30 (10x)	Tornillo M12x30 (10x)	16
17	8 710 103 096 0	Dichtungs-Set 100x109D - 115/138Dx3 (1x)	Set of seals 100x109D - 115/138Dx3 (1x)	Jeu de joints 100x109D - 115/138Dx3 (1x)	Set guarnizioni 100x109D - 115/138Dx3	DICHTING FLENS SK...2ZB-3ZB (VANAF 070)	conjunto de juntas 100x109D - 115/138Dx3	23
18	8 715 503 170 0	Flansch mit Tauchrohr kpl.	Connecting flange	Bride de raccordement	Flangia	FLENS + DICHTING SK - 3ZB	Conjunto brida y junta SK500	40
	7 709 500 052	Überdruckventil 1/2"3/4" 10 bar	VÁLVULA SEG. 1/2"3/4" 10 bar	VÁLVULA SEG. 1/2"3/4" 10 bar	Valvola di sovrappressione 1/2"3/4" 10 bar	Overdrukvelligheid 1/2"3/4" 10 bar	VÁLVULA SEG. 1/2"3/4" 10 bar	
	7 709 500 080	Rückschlagventil 1"	Non-return valve 1"	Soupape de non-retour 1"	Valvola di non ritorno 1"	Terugslagklep 1"	válvula de retención 1"	
	8 718 220 039 0	Hülse 1 1/4"	Sleeve 1 1/4"	Douille 1 1/4"	Bocchetta 1 1/4"	Bus 1 1/4"	Manguito 1 1/4"	09

For:

Ersatzteilliste  
Spare parts list  
Liste des pièces de rechange  
Lista parti di ricambio  
Onderdelenlijst  
Lista de repuestos

# SK400SOLAR - 7719001373

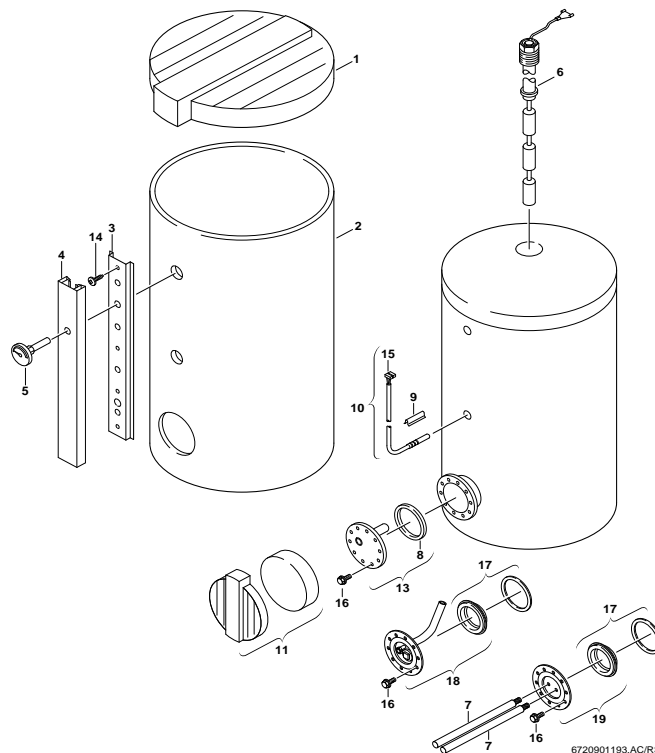

Pos	Bestell-Nr.	Bezeichnung	Description	Dénomination	Descrizione	Benaming	Descripción	PG
1	8 715 503 248 0	Haube grau	Hood grey	Capot gris	Carpot grigio	Deksel grijs	Tapa superior	42
1	8 715 503 437 0	Haube hellgrau	Hood light grey	Carpot gris clair	Coperchio grigio chiaro	Deksel lichtgrijs	Capota girar claro	42
2	8 715 401 303 0	Mantel weiß	Shell white	HABILLAGE BLANC SH370	Mantello bianco	Mantel wit	Carcasa blanco	51
3	8 718 005 564 0	Schiene	Frame	Structure	Telaio	Frame	Respaldo	32
4	8 715 503 251 0	Abdeckung grau	Covering sheet grey	Couvercle gris	Coperchio grigio	AFDEKPLAAT SK 300-3Z	Tapa	42
4	8 715 503 435 0	Abdeckung hellgrau	Covering sheet light grey	Couvercle gris clair	Coperchio grigio chiaro	Afdichting lichtgrijs	Chapa de protección girar claro	42
5	8 717 208 059 0	Thermometer	Thermometer	Thermomètre	Termometro	THERMOMETER SK 300-3ZB	Termómetro	38
6	8 709 918 666 0	Anode 1"	Anode 1"	Anode 1"	Anodo 1"	ANODE (KETTING) ST120/160-1E /SK 130-3Z	Anodo 1"	43
8	8 710 103 096 0	Dichtungs-Set 100x109D - 115/138Dx3 (1x)	Set of seals 100x109D - 115/138Dx3 (1x)	Jeu de joints 100x109D - 115/138Dx3 (1x)	Set guarnizioni 100x109D - 115/138Dx3	DICHTING FLENS SK -22B-3ZB (VANAF 070)	conjunto de juntas 100x109D - 115/138Dx3	23
8	8 710 103 145 0	Dichtring 190/245Dx3	Washer	Joint	Guarnizione	DICHTING FLENS SK 300-3ZB (TOT FD 07/03)	Anillo junta	30
9	8 714 606 021 0	Klemmfeder	Clamp spring	Ressort	Fermo	KLEMMVEER NTC SK120/A40/160-4ZB	Muelle de tecla	25
10	8 714 500 034 0	Sensor WW-NTC mit Aderendhülse 6m	Temperature sensor 6mm	SONDE DE TEMPERATURE 6mm	Sensore termometrico 6mm	Temperatuurvoeler 6mm	Sensor de temperatura 6mm	34
11	8 715 503 247 0	Abdeckung grau	Covering sheet grey	Couvercle gris	Coperchio grigio	Afdichting grijs	Chapa protección	40
11	8 715 503 436 0	Abdeckung hellgrau	Covering sheet light grey	Couvercle gris clair	Coperchio grigio chiaro	Afdichting lichtgrijs	Chapa de protección girar claro	40
13	8 715 503 252 0	Flansch	Connecting flange	Bride de raccordement	Flangia	FLENS SK 300-3ZB	Brida de conexión	47
14	8 713 403 008 0	Schraube (10x)	Screw	Vis (10x)	Vite (10x)	Schroef (10x)	Tornillo (10x)	11
15	8 711 006 060 0	Stecker	Plug	Connecteur	Spina	STEKKER NTC-VOELER ST...1ESK 300/ST 75	Anection	16
16	2 911 060 291 0	Schraube M10x25 (10x)	Screw M10x25 (10x)	Vis M10x25 (10x)	Vite M10x25 (10x)	Schroef M10x25 (10x)	Tornillo M10x25 (10x)	18
16	2 911 060 342 0	Schraube M12x30 (10x)	Screw M12x30 (10x)	Vis M12x30 (10x)	Vite M12x30 (10x)	Schroef M12x30 (10x)	Tornillo M12x30 (10x)	16
17	8 710 103 096 0	Dichtungs-Set 100x109D - 115/138Dx3 (1x)	Set of seals 100x109D - 115/138Dx3 (1x)	Jeu de joints 100x109D - 115/138Dx3 (1x)	Set guarnizioni 100x109D - 115/138Dx3	DICHTING FLENS SK -22B-3ZB (VANAF 070)	conjunto de juntas 100x109D - 115/138Dx3	23
18	8 715 503 170 0	Flansch mit Tauchrohr kpl.	Connecting flange	Bride de raccordement	Flangia	FLENS + DICHTING SK - 3ZB	Conjunto brida y junta SK500	40
	8 718 220 039 0	Hülse 1 1/4"	Sleeve 1 1/4"	Douille 1 1/4"	Bocchetta 1 1/4"	Bus 1 1/4"	Manguito 1 1/4"	09

For:

**Ersatzteilliste**

Spare parts list

Liste des pièces de rechange

Lista parti di ricambio

Onderdelenlijst

Lista de repuestos

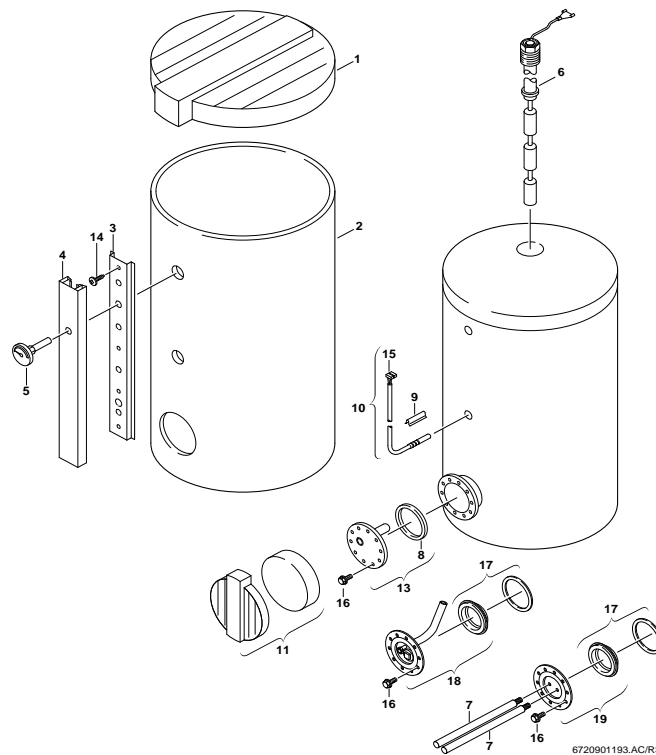
**SK400SOLARS3500 - 7719001467**

Pos	Bestell-Nr.	Bezeichnung	Description	Dénomination	Descrizione	Benaming	Descripción	PG
1	8 715 503 248 0	Haube grau	Hood grey	Capot gris	Carpot grigio	Deksel grijs	Tapa superior	42
2	8 715 401 303 0	Mantel weiß	Shell white	HABILLAGE BLANC SH370	Mantello bianco	Mantel wit	Carcasa blanco	51
3	8 718 005 564 0	Schiene	Frame	Structure	Telaio	Frame	Respaldo	32
4	8 715 503 251 0	Abdeckung grau	Covering sheet grey	Couvercle gris	Coperchio grigio	AFDEKPLAAT SK 300-3Z	Tapa	42
5	8 717 208 059 0	Thermometer	Thermometer	Thermomètre	Termometro	THERMOMETER SK 300-3ZB	Termómetro	38
6	8 709 918 666 0	Anode 1"	Anode 1"	Anode 1"	Anodo 1"	ANODE (KETTING) ST120/160-1E./SK 130-3Z	Anodo 1"	43
8	8 710 103 096 0	Dichtungs-Set 100x109D - 115/138Dx3 (1x)	Set of seals 100x109D - 115/138Dx3 (1x)	Jeu de joints 100x109D - 115/138Dx3 (1x)	Set guarnizioni 100x109D - 115/138Dx3	DICHTING FLENS SK...22B/-3ZB (VANA F 070)	conjunto de juntas 100x109D - 115/138Dx3	23
8	8 710 103 145 0	Dichtring 190/245Dx3	Washer	Joint	Guarnizione	DICHTING FLENS SK 300-3ZB (TOT FD 07/03)	Anillo junta	30
9	8 714 606 021 0	Klemmfeder	Clamp spring	Ressort	Fermo	KLEMVEER NTC SK120/140/160-4ZB	Muelle de tecla	25
10	8 714 500 034 0	Sensor WW-NTC mit Aderendhülse 6m	Temperature sensor 6mm	SONDE DE TEMPERATURE 6mm	Sensore termometrico 6mm	Temperatuurvoeler 6mm	Sensor de temperatura 6mm	34
11	8 715 503 247 0	Abdeckung grau	Covering sheet grey	Couvercle gris	Coperchio grigio	Afdichting grijs	Chapa protección	40
13	8 715 503 252 0	Flansch	Connecting flange	Bride de raccordement	Flangia	FLENS SK 300-3ZB	Brida de conexión	47
14	8 713 403 008 0	Schraube (10x)	Screw	Vis (10x)	Vite (10x)	Schroef (10x)	Tornillo (10x)	11
15	8 711 006 060 0	Stecker	Plug	Connecteur	Spina	STECKER NTC-VOELER ST...1E/SK 300/ST 75	Anection	16
16	2 911 060 291 0	Schraube M10x25 (10x)	Screw M10x25 (10x)	Vis M10x25 (10x)	Vite M10x25 (10x)	Schroef M10x25 (10x)	Tornillo M10x25 (10x)	18
16	2 911 060 342 0	Schraube M12x30 (10x)	Screw M12x30 (10x)	Vis M12x30 (10x)	Vite M12x30 (10x)	Schroef M12x30 (10x)	Tornillo M12x30 (10x)	16
17	8 710 103 096 0	Dichtungs-Set 100x109D - 115/138Dx3 (1x)	Set of seals 100x109D - 115/138Dx3 (1x)	Jeu de joints 100x109D - 115/138Dx3 (1x)	Set guarnizioni 100x109D - 115/138Dx3	DICHTING FLENS SK...22B/-3ZB (VANA F 070)	conjunto de juntas 100x109D - 115/138Dx3	23
18	8 715 503 170 0	Flansch mit Tauchrohr kpl.	Connecting flange	Bride de raccordement	Flangia	FLENS + DICHTING SK - 3ZB	Conjunto brida y junta SK500	40
	8 718 220 039 0	Hülse 1 1/4"	Sleeve 1 1/4"	Douille 1 1/4"	Bocchetta 1 1/4"	Bus 1 1/4"	Manguito 1 1/4"	09

For:

Ersatzteilliste  
Spare parts list  
Liste des pièces de rechange  
Lista parti di ricambio  
Onderdelenlijst  
Lista de repuestos

**SK450-2Z - 7739100139**

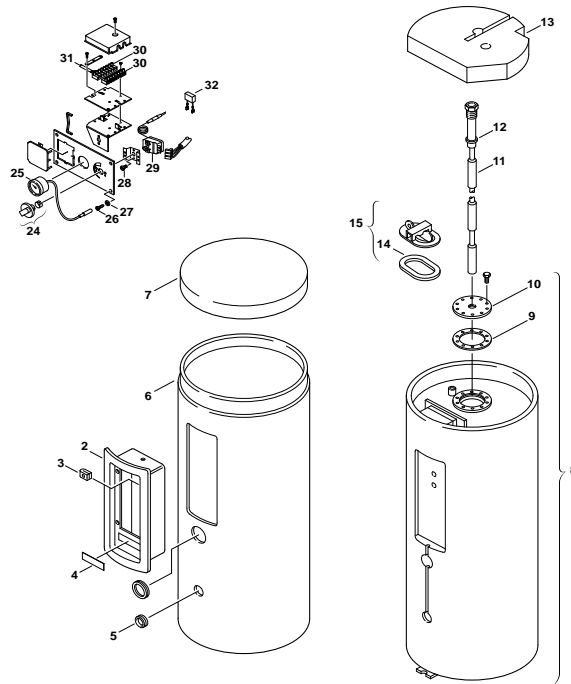

6720901218.AC/G

Pos	Bestell-Nr.	Bezeichnung	Description	Dénomination	Descrizione	Benaming	Descripción	PG
2	8 715 506 262 0	Rahmen	Frame	Cadre-support	Conice	Frame	Respaldo	42
3	8 713 309 026 0	Mutter (10x)	Nut	Ecrou (10x)	Dado (10x)	Moer (10x)	Tuerca (10x)	12
4	8 701 103 029 0	Warenzeichen	Trade mark badge	Marquage	Targhetta	Fabrieksmerk	Marca	15
5	8 710 506 080 0	Stopfen	Grommet	Bouchon	Coperchietto	Doorvoertule	Tapon	11
6	8 715 401 268 0	Mantel	Outer_case	Habillage	Mantello	Mantel	Carcasa	54
7	8 718 006 640 0	Haube	Hood	Capot	Carpot	Deksel	Capota	43
8	8 715 407 044 0	Behälter	Reservoir	Récipient	Sostegno	Reservoir	Déposito	53
9	8 710 103 087 0	Dichtung	Washer	Joint	Guarnizione	DICHTING FLENS SK 300/2Z (VANAF FD 744)	Junta	24
10	8 715 503 145 0	Flansch	Connecting flange	Bride de raccordement	Flangia	Aansluitflens	Brida de conexión	41
11	8 709 918 506 0	Anode	Anode	Anode	Anodo	ANODE SO 160-160/1-200-200/1-SK 160-300	Anodo	43
11	8 709 918 513 0	Anode	Anode	Anode	Anodo	Anode	Anodo	57
12	8 710 103 086 0	Dichtscheibe (10x)	Washer (10x)	Joint (10x)	Guarnizione (10x)	DICHTING ANODE VOOR SO 160	Junta (10x)	22
13	8 718 006 398 0	Isolierung	Insulation	Isolation	Isolamento	Isolatie	Aislamiento	24
14	8 730 103 973 0	Dichtung	Washer	Joint	Guarnizione	Pakkingring	Junta	31
24	8 712 000 034 0	Drehknopf	Rotary handle	Bouton de réglage	Manopola	Regelknop	Botón rotativo	12
25	8 737 208 991 0	Thermometer	Thermometer	Thermomètre	Termometro	THERMOMETER SO...SK...-ZZ-3Z - Z(W)...F	Termómetro	37
26	8 713 403 008 0	Schraube (10x)	Screw	Vis (10x)	Vite (10x)	Schroef (10x)	Tornillo (10x)	11
27	2 916 030 006 0	Sicherungsscheibe (10x)	Retaining ring (10x)	Circlips (10x)	Rondella (10x)	BORGRING UIT TTB 771900055P	Arandela de seguridad (10x)	11
29	8 717 206 186 0	Temperaturregler	Flow thermostat	Thermostat	Thermostat	AQUASTAAT MWISSELKONTAKT SO 120-160-200	Regulador de temperatura	36
30	8 711 006 046 0	Klemmleiste 24V	Terminal strip 24V	Bornier 24V	Cablaggio 24V	Klemmenstrook 24V	Regleta de bornes 24V	08
31	8 714 401 396 0	Kabel	Cable	Faisceau	Cablaggio	Kabel	Cable	23
32	8 717 301 017 0	Entstörkondensator	ENTSTÖRKONDENSATOR	Condensateur	Condensatore	CONDENSATOR VOOR AQUASTAAT 8 737 206 974	Condensador filtro	14

For:

Ersatzteilliste  
 Spare parts list  
 Liste des pièces de rechange  
 Lista parti di ricambio  
 Onderdelenlijst  
 Lista de repuestos

# SK500-1SOLAR - 7739300911

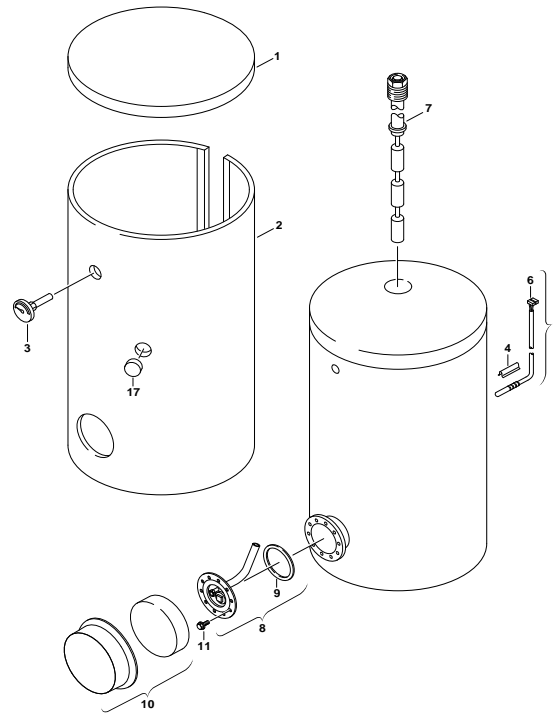

6720901194.AC/G

Pos	Bestell-Nr.	Bezeichnung	Description	Dénomination	Descrizione	Benaming	Descripción	PG
1	<b>8 715 503 345 0</b>	Haube hellgrau	Hood light grey	Carpot gris clair	Coperchio grigio chiaro	Deksel lichtgrijs	Capota gris claro	41
2	<b>8 715 401 448 0</b>	Mantel weiß	Front shell white	Habillage blanc	Mantello bianco	Mantel wit	Carcasa blanco	52
3	<b>8 717 208 050 0</b>	Thermometer	Thermometer	Thermomètre	Termometro	Thermometer	Termómetro	31
4	<b>8 714 606 021 0</b>	Klemmfeder	Clamp spring	Ressort	Fermo	KLEMVEER NTC SK120/140/160-4ZB	Muelle de tecla	25
5	<b>8 714 500 034 0</b>	Sensor WW-NTC mit Aderendhülse 6mm	Temperature sensor 6mm	SONDE DE TEMPERATURE 6mm	Sensore termometrico 6mm	Temperatuurvoeler 6mm	Sensor de temperatura 6mm	34
6	<b>8 711 006 060 0</b>	Stecker	Plug	Connecteur	Spina	STEKKER NTC-VOELER ST.-1ESK 300ST 75	Aneccion	16
7	<b>8 709 918 506 0</b>	Anode	Anode	Anode	Anodo	ANODE SO 160-160/1-200-200/1-SK 180-300-	Anodo	43
7	<b>8 709 918 666 0</b>	Anode 1"	Anode 1"	Anode 1"	Anodo 1"	ANODE (KETTING) ST120/160-1E/1SK 130-3Z	Anodo 1"	43
8	<b>8 715 503 170 0</b>	Flansch mit Tauchrohr kpl.	Connecting flange	Bride de raccordement	Flangia	FLENS + DICHTING SK - 3ZB	Conjunto brida y junta SK500	40
9	<b>8 710 103 096 0</b>	Dichtungs-Set 100x109D - 115/138Dx3 (1x)	Set of seals 100x109D - 115/138Dx3 (1x)	Jeu de joints 100x109D - 115/138Dx3 (1x)	Set guarnizioni 100x109D - 115/138Dx3	DICHTING FLENS SK.-2ZB-3ZB (VANAF 070)	conjunto de juntas 100x109D - 115/138Dx3	23
10	<b>8 715 503 346 0</b>	Abdeckung hellgrau	Covering sheet light grey	Couvercle gris clair	Coperchio grigio chiaro	DEKSEL SK 300-1/400-1/500-1 SOLAR	Chapa de protección girar claro	33
11	<b>2 911 060 291 0</b>	Schraube M10x25 (10x)	Screw M10x25 (10x)	Vis M10x25 (10x)	Vite M10x25 (10x)	Schroef M10x25 (10x)	Tornillo M10x25 (10x)	18
11	<b>2 911 060 342 0</b>	Schraube M12x30 (10x)	Screw M12x30 (10x)	Vis M12x30 (10x)	Vite M12x30 (10x)	Schroef M12x30 (10x)	Tornillo M12x30 (10x)	16
17	<b>8 715 503 239 0</b>	Isolierung	Insulation	Bouchon	Isolamento	ISOLATIE SK 300-1 SOLAR (7719001929)	Aislamiento	23
	<b>8 718 220 038 0</b>	Hülse 1"	Sleeve 1"	Douille 1"	Bocchetta 1"	ISOLATIE DEKSEL SK 300-1/400-1/500-1 SOL	Manguito 1"	09

For: \_\_\_\_\_

Ersatzteilliste  
 Spare parts list  
 Liste des pièces de rechange  
 Lista parti di ricambio  
 Onderdelenlijst  
 Lista de repuestos

**SK500-3ZB - 7719002879**

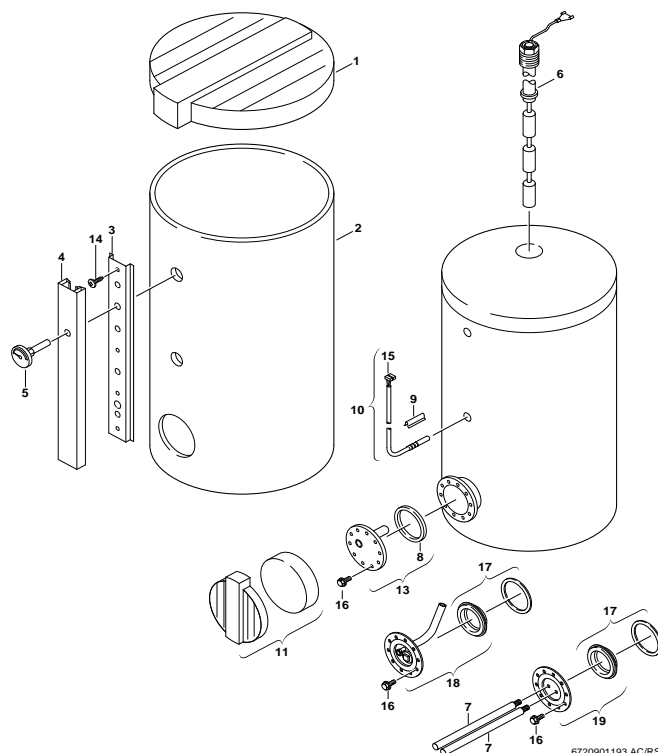

Pos	Bestell-Nr.	Bezeichnung	Description	Dénomination	Descrizione	Benaming	Descripción	PG
1	8 715 503 248 0	Haube grau	Hood grey	Capot gris	Carpot grigio	Deksel grijs	Tapa superior	42
1	8 715 503 437 0	Haube hellgrau	Hood light grey	Carpot gris clair	Coperchio grigio chiaro	Deksel lichtgrijs	Capota girar claro	42
2	8 715 401 304 0	Mantel weiß	Shell white	Habillage blanc	Mantello bianco	Mantel wit	Carcasa blanco	52
3	8 718 005 563 0	Schiene	Frame	Structure	Telaio	Frame	Respaldo	31
4	8 715 503 251 0	Abdeckung grau	Covering sheet grey	Couvercle gris	Coperchio grigio	AFDEKPLAAT SK 300-3Z	Tapa	42
4	8 715 503 435 0	Abdeckung hellgrau	Covering sheet light grey	Couvercle gris clair	Coperchio grigio chiaro	Afdichting lichtgrijs	Chapa de protección girar claro	42
5	8 717 208 059 0	Thermometer	Thermometer	Thermomètre	Termometro	THERMOMETER SK 300-3ZB	Termómetro	38
6	8 709 918 666 0	Anode 1"	Anode 1"	Anode 1"	Anodo 1"	ANODE (KETTING) ST120/160-1E /SK 130-3Z	Anodo 1"	43
9	8 714 606 021 0	Klemmfeder	Clamp spring	Ressort	Fermo	KLEMVEER NTC SK120/140/160-4ZB	Muelle de tecla	25
10	8 714 500 034 0	Sensor WW-NTC mit Aderendhülse 6m	Temperature sensor 6mm	SONDE DE TEMPERATURE 6mm	Sensore termometrico 6mm	Temperatuurvoeler 6mm	Sensor de temperatura 6mm	34
11	8 715 503 247 0	Abdeckung grau	Covering sheet grey	Couvercle gris	Coperchio grigio	Afdichting grijs	Chapa protección	40
11	8 715 503 436 0	Abdeckung hellgrau	Covering sheet light grey	Couvercle gris clair	Coperchio grigio chiaro	Afdichting lichtgrijs	Chapa de protección girar claro	40
14	8 713 403 008 0	Schraube (10x)	Screw	Vis (10x)	Vite (10x)	Schroef (10x)	Tornillo (10x)	11
15	8 711 006 060 0	Stecker	Plug	Connecteur	Spina	STEKKER NTC-VOELER ST...1E/SK 300/ST 75	Anection	16
16	2 911 060 291 0	Schraube M10x25 (10x)	Screw M10x25 (10x)	Vis M10x25 (10x)	Vite M10x25 (10x)	Schroef M10x25 (10x)	Tornillo M10x25 (10x)	18
16	2 911 060 342 0	Schraube M12x30 (10x)	Screw M12x30 (10x)	Vis M12x30 (10x)	Vite M12x30 (10x)	Schroef M12x30 (10x)	Tornillo M12x30 (10x)	16
17	8 710 103 096 0	Dichtungs-Set 100x109D - 115/138Dx3 (1x)	Set of seals 100x109D - 115/138Dx3 (1x)	Jeu de joints 100x109D - 115/138Dx3 (1x)	Set guarnizioni 100x109D - 115/138Dx3	DICHTING FLENS SK...ZZB-3ZB (VANAAF 070)	conjunto de juntas 100x109D - 115/138Dx3	23
18	8 715 503 170 0	Flansch mit Tauchrohr kpl.	Connecting flange	Bride de raccordement	Flangia	FLENS + DICHTING SK - 3ZB	Conjunto brida y junta SK500	40
	8 718 220 039 0	Hülse 1 1/4"	Sleeve 1 1/4"	Douille 1 1/4"	Bocchetta 1 1/4"	Bus 1 1/4"	Manguito 1 1/4"	09

For:

Ersatzteilliste  
Spare parts list  
Liste des pièces de rechange  
Lista parti di ricambio  
Onderdelenlijst  
Lista de repuestos

**SK500-3ZB - 7747020296**

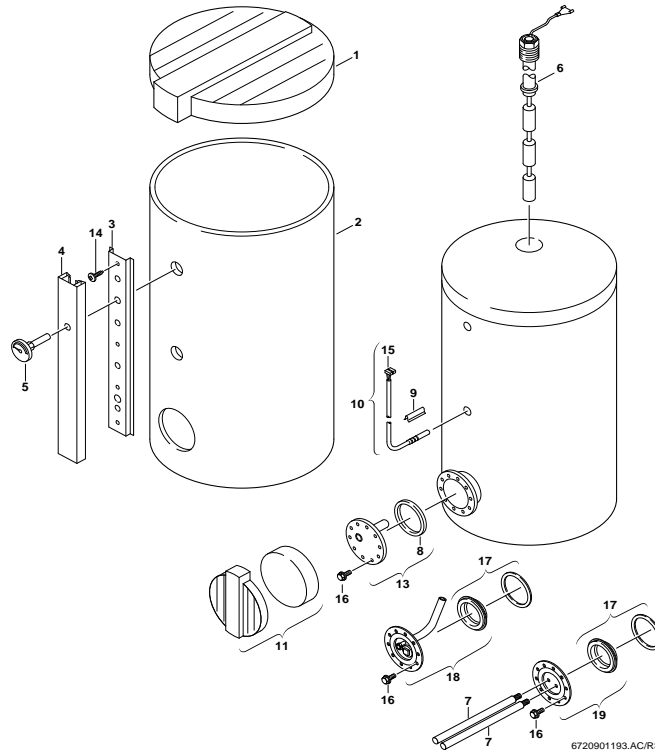

Pos	Bestell-Nr.	Bezeichnung	Description	Dénomination	Descrizione	Benaming	Descripción	PG
1	8 715 503 437 0	Haube hellgrau	Hood light grey	Carpot gris clair	Coperchio grigio chiaro	Deksel lichtgrijs	Capota girar claro	42
2	8 715 401 304 0	Mantel weiß	Shell white	Habillage blanc	Mantello bianco	Mantel wit	Carcasa blanco	52
3	8 718 005 565 0	Schiene	Bar	Barre	Binario	Strip	rail	34
4	8 715 503 435 0	Abdeckung hellgrau	Covering sheet light grey	Couvercle gris clair	Coperchio grigio chiaro	Afdichting lichtgrijs	Chapa de protección girar claro	42
5	8 717 208 059 0	Thermometer	Thermometer	Thermomètre	Termometro	THERMOMETER SK 300-3ZB	Termómetro	38
7	8 719 918 981 0	Anode	Anode	Anode	Anodo	Anode	Anodo	43
9	8 714 606 021 0	Klemmfeder	Clamp spring	Ressort	Fermo	KLEMVEER NTC SK120/140/160-4ZB	Muelle de tecla	25
10	8 714 500 034 0	Sensor WW-NTC mit Aderendhülse 6m	Temperature sensor 6mm	SONDE DE TEMPERATURE 6mm	Sensore termometrico 6mm	Temperatuurvoeler 6mm	Sensor de temperatura 6mm	34
11	8 715 503 436 0	Abdeckung hellgrau	Covering sheet light grey	Couvercle gris clair	Coperchio grigio chiaro	Afdichting lichtgrijs	Chapa de protección girar claro	40
14	8 713 403 008 0	Schraube (10x)	Screw	Vis (10x)	Vite (10x)	Schroef (10x)	Tornillo (10x)	11
15	8 711 006 060 0	Stecker	Plug	Connecteur	Spina	STEKKER NTC-VOELER ST...1ESK 300ST 75	Anection	16
16	2 911 060 291 0	Schraube M10x25 (10x)	Screw M10x25 (10x)	Vis M10x25 (10x)	Vite M10x25 (10x)	Schroef M10x25 (10x)	Tornillo M10x25 (10x)	18
17	8 710 103 096 0	Dichtungs-Set 100x109D - 115/138Dx3 (1x)	Set of seals 100x109D - 115/138Dx3 (1x)	Jeu de joints 100x109D - 115/138Dx3 (1x)	Set guarnizioni 100x109D - 115/138Dx3	DICHTING FLENS SK...2ZB/3ZB (VANAF 070)	conjunto de juntas 100x109D - 115/138Dx3	23
19	8 715 503 526 0	Flansch DN120	Connecting flange	Trappe de visite	Flangia	Aansluitflens	Brida de conexión	38
	8 718 220 039 0	Hülse 1 1/4"	Sleeve 1 1/4"	Douille 1 1/4"	Bocchetta 1 1/4"	Bus 1 1/4"	Manguito 1 1/4"	09

For:

**Ersatzteilliste**

Spare parts list

Liste des pièces de rechange

Lista parti di ricambio

Onderdelenlijst

Lista de repuestos

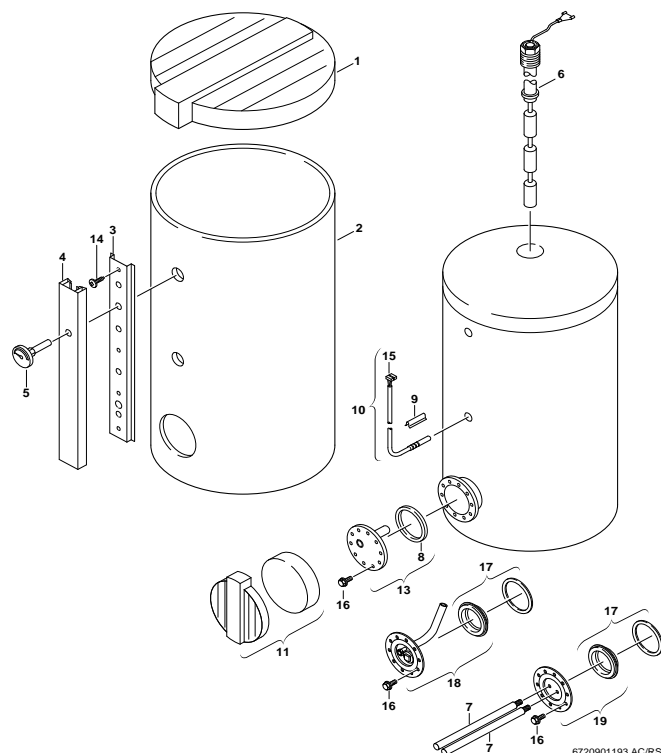
**SK500-3ZB S0400 - 7747020289**

6720901193.AC/RS

Pos	Bestell-Nr.	Bezeichnung	Description	Dénomination	Descrizione	Benaming	Descripción	PG
1	8 715 503 437 0	Haube hellgrau	Hood light grey	Carpot gris clair	Coperchio grigio chiaro	Deksel lichtgrijs	Capota girar claro	42
2	8 715 401 304 0	Mantel weiß	Shell white	Habillage blanc	Mantello bianco	Mantel wit	Carcasa blanco	52
3	8 718 005 565 0	Schiene	Bar	Barre	Binario	Strip	rail	34
4	8 715 503 435 0	Abdeckung hellgrau	Covering sheet light grey	Couvercle gris clair	Coperchio grigio chiaro	Afdichting lichtgrijs	Chapa de protección girar claro	42
5	8 717 208 059 0	Thermometer	Thermometer	Thermomètre	Termometro	THERMOMETER SK 300-3ZB	Termómetro	38
7	8 719 918 981 0	Anode	Anode	Anode	Anodo	Anode	Anodo	43
8	8 710 103 145 0	Dichtring 190/245Dx3	Washer	Joint	Guarnizione	DICHTING FLENS SK 300-3ZB (TOT FD 07/03)	Anillo junta	30
9	8 714 606 021 0	Klemmfeder	Clamp spring	R ressort	Fermo	KLEEMVEER NTC SK 120/140/160-4ZB	Muelle de tecla	25
10	8 714 500 034 0	Sensor WW-NTC mit Aderendhülse 6mm	Temperature sensor 6mm	SONDE DE TEMPERATURE 6mm	Sensore termometrico 6mm	Temperatuurvoeler 6mm	Sensor de temperatura 6mm	34
11	8 715 503 436 0	Abdeckung hellgrau	Covering sheet light grey	Couvercle gris clair	Coperchio grigio chiaro	Afdichting lichtgrijs	Chapa de protección girar claro	40
14	8 713 403 008 0	Schraube (10x)	Screw	Vis (10x)	Vite (10x)	Schroef (10x)	Tornillo (10x)	11
15	8 711 006 060 0	Stecker	Plug	Connecteur	Spina	STEKKER NTC-VOELER ST...1E/SK 300/ST 75	Anection	16
16	2 911 060 291 0	Schraube M10x25 (10x)	Screw M10x25 (10x)	Vis M10x25 (10x)	Vite M10x25 (10x)	Schroef M10x25 (10x)	Tornillo M10x25 (10x)	18
17	8 710 103 096 0	Dichtungs-Set 100x109D - 115/138Dx3 (1x)	Set of seals 100x109D - 115/138Dx3 (1x)	Jeu de joints 100x109D - 115/138Dx3 (1x)	Set guarnizioni 100x109D - 115/138Dx3	DICHTING FLENS SK...2ZB/3ZB (VANAF 07/0)	conjunto de juntas 100x109D - 115/138Dx3	23
19	8 715 503 526 0	Flansch DN120	Connecting flange	Trappe de visite	Flangia	Aansluitflens	Brida de conexión	38
	8 718 220 039 0	Hülse 1 1/4"	Sleeve 1 1/4"	Douille 1 1/4"	Bocchetta 1 1/4"	Bus 1 1/4"	Manguito 1 1/4"	09
For:								



Ersatzteilliste  
Spare parts list  
Liste des pièces de rechange  
Lista parti di ricambio  
Onderdelenlijst  
Lista de repuestos

## SK500-3ZB/C2 - 7719002124

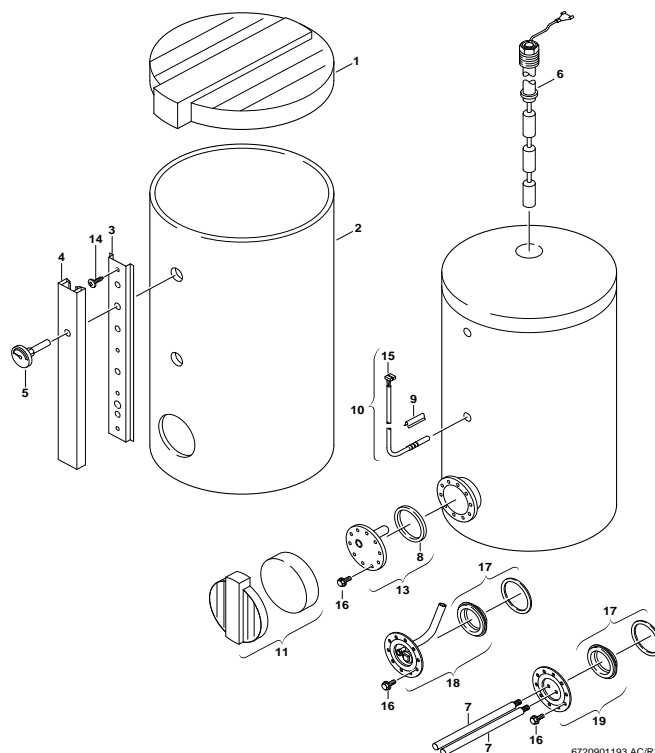

Pos	Bestell-Nr.	Bezeichnung	Description	Dénomination	Descrizione	Benaming	Descripción	PG
1	8 715 503 418 0	Haube silbergrau	Hood silver grey	Carpot argent gris	Coperchio argentato grigio	Deksel zilvergrijs	Capota plata girar	42
2	8 715 401 392 0	Mantel silbergrau	Front shell silver grey	Habillage argent gris	Mantello argentato grigio	Mantel zilver grijs	Carcasa plata girar	52
3	8 718 005 565 0	Schiene	Bar	Barre	Binario	Strip	rail	34
4	8 715 503 431 0	Abdeckung gelb	Covering sheet yellow	Couvercle jaune	Coperchio giallo	Afdichting geel	Chapa de protección amarillo	42
5	8 717 208 059 0	Thermometer	Thermometer	Thermomètre	Termometro	THERMOMETER SK 300-3ZB	Termómetro	38
7	8 719 918 981 0	Anode	Anode	Anode	Anodo	Anode	Anodo	43
8	8 710 103 145 0	Dichtring 190/245Dx3	Washer	Joint	Guarnizione	DICHTING FLENS SK 300-3ZB (TOT FD 07/03)	Anillo junta	30
9	8 714 606 021 0	Klemmfeder	Clamp spring	R ressort	Fermo	KLEEMVEER NTC SK120/140/160-4ZB	Muelle de tecla	25
10	8 714 500 034 0	Sensor WW-NTC mit Aderendhülse 6mm	Temperature sensor 6mm	SONDE DE TEMPERATURE 6mm	Sensore termometrico 6mm	Temperatuurvoeler 6mm	Sensor de temperatura 6mm	34
11	8 715 503 423 0	Abdeckung silbergrau	Covering sheet silver grey	Couvercle argent gris	Coperchio argentato grigio	Afdichting zilver grijs	Chapa de protección plata girar	40
14	8 713 403 008 0	Schraube (10x)	Screw	Vis (10x)	Vite (10x)	Schroef (10x)	Tornillo (10x)	11
15	8 711 006 060 0	Stecker	Plug	Connecteur	Spina	STECKER NTC-VOELER ST.-1ESK 300/ST 75	Anection	16
16	2 911 060 291 0	Schraube M10x25 (10x)	Screw M10x25 (10x)	Vis M10x25 (10x)	Vite M10x25 (10x)	Schroef M10x25 (10x)	Tornillo M10x25 (10x)	18
16	2 911 060 342 0	Schraube M12x30 (10x)	Screw M12x30 (10x)	Vis M12x30 (10x)	Vite M12x30 (10x)	Schroef M12x30 (10x)	Tornillo M12x30 (10x)	16
17	8 710 103 096 0	Dichtungs-Set 100x109D - 115/138Dx3 (1x)	Set of seals 100x109D - 115/138Dx3 (1x)	Jeu de joints 100x109D - 115/138Dx3 (1x)	Set guarnizioni 100x109D - 115/138Dx3	DICHTING FLENS SK.-2ZB/-3ZB (VANAF 07/0)	conjunto de juntas 100x109D - 115/138Dx3	23
19	8 715 503 526 0	Flansch DN120	Connecting flange	Trappe de visite	Flangia	Aansluitflens	Brida de conexión	38
	8 718 220 039 0	Hülse 1 1/4"	Sleeve 1 1/4"	Douille 1 1/4"	Bocchetta 1 1/4"	Bus 1 1/4"	Manguito 1 1/4"	09

For:

Ersatzteilliste  
Spare parts list  
Liste des pièces de rechange  
Lista parti di ricambio  
Onderdelenlijst  
Lista de repuestos

**SK500-3ZBS3500 - 7719001465**

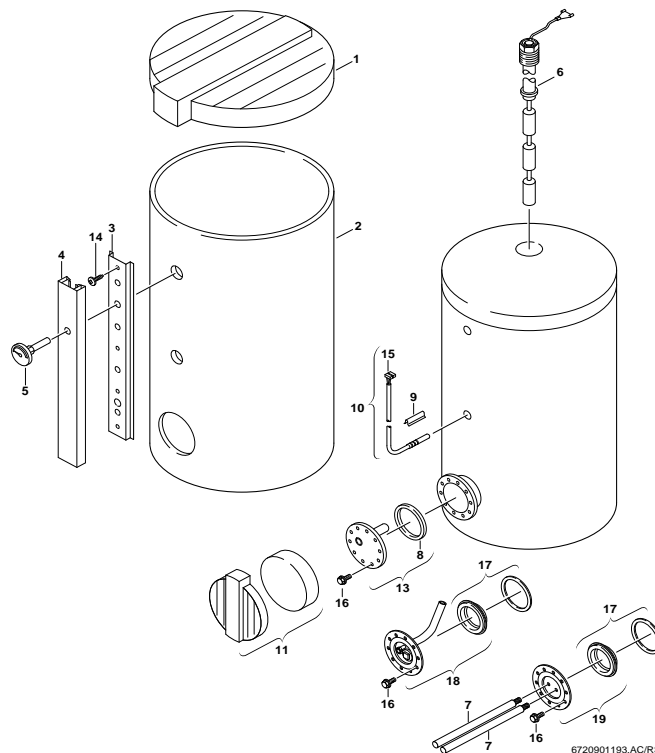

Pos	Bestell-Nr.	Bezeichnung	Description	Dénomination	Descrizione	Benaming	Descripción	PG
1	8 715 503 248 0	Haube grau	Hood grey	Capot gris	Carpot grigio	Deksel grijs	Tapa superior	42
1	8 715 503 437 0	Haube hellgrau	Hood light grey	Carpot gris clair	Coperchio grigio chiaro	Deksel lichtgrijs	Capota girar claro	42
2	8 715 401 304 0	Mantel weiß	Shell white	Habillage blanc	Mantello bianco	Mantel wit	Carcasa blanco	52
3	8 718 005 565 0	Schiene	Bar	Barre	Binario	Strip	rail	34
4	8 715 503 251 0	Abdeckung grau	Covering sheet grey	Couvercle gris	Coperchio grigio	AFDEKPLAAT SK 300-3Z	Tapa	42
4	8 715 503 435 0	Abdeckung hellgrau	Covering sheet light grey	Couvercle gris clair	Coperchio grigio chiaro	Afdichting lichtgrijs	Chapa de protección girar claro	42
5	8 717 208 059 0	Thermometer	Thermometer	Thermomètre	Termometro	THERMOMETER SK 300-3ZB	Termómetro	38
7	8 719 918 981 0	Anode	Anode	Anode	Anodo	Anode	Anodo	43
8	8 710 103 145 0	Dichtring 190/245Dx3	Washer	Joint	Guarnizione	DICHTING FLENS SK 300-3ZB (TOT FD 07/03)	Anillo junta	30
9	8 714 606 021 0	Klemmfeder	Clamp spring	Ressort	Fermo	KLEMVEER NTC SK120/140/160-4ZB	Muelle de tecla	25
10	8 714 500 034 0	Sensor WW-NTC mit Aderendhülse 6m	Temperature sensor 6mm	SONDE DE TEMPERATURE 6mm	Sensore termometrico 6mm	Temperatuurvoeler 6mm	Sensor de temperatura 6mm	34
11	8 715 503 247 0	Abdeckung grau	Covering sheet grey	Couvercle gris	Coperchio grigio	Afdichting grijs	Chapa protección	40
11	8 715 503 436 0	Abdeckung hellgrau	Covering sheet light grey	Couvercle gris clair	Coperchio grigio chiaro	Afdichting lichtgrijs	Chapa de protección girar claro	40
14	8 713 403 008 0	Schraube (10x)	Screw	Vis (10x)	Vite (10x)	Schroef (10x)	Tornillo (10x)	11
15	8 711 006 060 0	Stecker	Plug	Connecteur	Spina	STECKER NTC-VOELER ST...1ESK 300ST 75	Anection	16
16	2 911 060 291 0	Schraube M10x25 (10x)	Screw M10x25 (10x)	Vis M10x25 (10x)	Vite M10x25 (10x)	Schroef M10x25 (10x)	Tornillo M10x25 (10x)	18
16	2 911 060 342 0	Schraube M12x30 (10x)	Screw M12x30 (10x)	Vis M12x30 (10x)	Vite M12x30 (10x)	Schroef M12x30 (10x)	Tornillo M12x30 (10x)	16
17	8 710 103 096 0	Dichtungs-Set 100x109D - 115/138Dx3 (1x)	Set of seals 100x109D - 115/138Dx3 (1x)	Jeu de joints 100x109D - 115/138Dx3 (1x)	Set guarnizioni 100x109D - 115/138Dx3	DICHTING FLENS SK...2ZB-3ZB (VANAAF 07/0)	conjunto de juntas 100x109D - 115/138Dx3	23
19	8 715 503 526 0	Flansch DN120	Connecting flange	Trappe de visite	Flangia	Aansluitflens	Brida de conexión	38
	7 709 500 052	Überdruckventil 1/2"3/4" 10 bar	VÁLVULA SEG. 1/2"3/4" 10 bar	VÁLVULA SEG. 1/2"3/4" 10 bar	Valvola di sovrappressione 1/2"3/4" 10 bar	Overdrukvleigheid 1/2"3/4" 10 bar	VÁLVULA SEG. 1/2"3/4" 10 bar	
	7 709 500 080	Rückschlagventil 1"	Non-return valve 1"	Soupape de non-retour 1"	Valvola di non ritorno 1"	Terugslagklep 1"	válvula de retención 1"	
	8 718 220 039 0	Hülse 1 1/4"	Sleeve 1 1/4"	Douille 1 1/4"	Bocchetta 1 1/4"	Bus 1 1/4"	Manguito 1 1/4"	09

For:

Ersatzteilliste  
 Spare parts list  
 Liste des pièces de rechange  
 Lista parti di ricambio  
 Onderdelenlijst  
 Lista de repuestos

**SK750 - 7739300913**

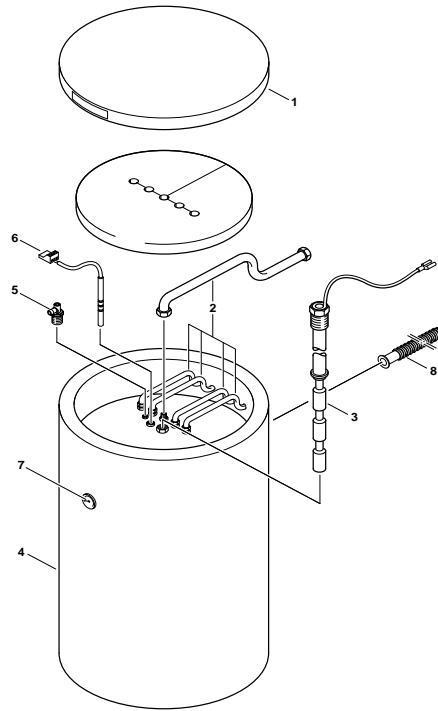

6720901041.AD/RS

Pos	Bestell-Nr.	Bezeichnung	Description	Dénomination	Descrizione	Benaming	Descripción	PG
1	<b>8 718 006 842 0</b>	Deckel silbergrau	Cover silver grey	Couvercle argent gris	Coperchio argentato grigio	Deksel zilver grijs	Tapa plata girar	32
2	<b>7 739 300 178</b>	ZL 103 Verbindungsrohr Wasser	ZL 103 connecting pipe water	ZL 103 Tube de raccordement eau	ZL 103 Tubo connes nichelxo xSP750solar	ZL-103 AANSLUITSET CIRCULATIELEIDING SP	ZL 103 tubería de conexión	
3	<b>8 709 918 666 0</b>	Anode 1"	Anode 1"	Anode 1"	Anodo 1"	ANODE (KETTING) ST120/160-1E /SK 130-3Z	Anodo 1"	43
4	<b>7 739 300 395</b>	Mantel weiss	FRONT SHELL WITHE	Habillage blanc	mantello bianco	Mantel wit	Mantello bianco	
4	<b>7 739 300 396</b>	Mantel silber	FRONT SHELL silver	Habillage argent	Carcasa plata	Mantel zilver	Mantello argento	
5	<b>8 719 918 722 0</b>	Entlüftungsventil	Vent valve	Dégazeur	Valvola di scarico	Ontluchtventiel	Válvula de purga de aire	13
6	<b>8 714 500 034 0</b>	Sensor WW-NTC mit Aderendhülse 6m	Temperature sensor 6mm	SONDE DE TEMPERATURE 6mm	Sensore termometrico 6mm	Temperatuurvoeler 6mm	Sensor de temperatura 6mm	34
7	<b>8 717 208 059 0</b>	Thermometer	Thermometer	Thermomètre	Termometro	THERMOMETER SK 300-3ZB	Termómetro	38
8	<b>8 718 225 083 0</b>	Rohr-KW-Rohr, 1670mm lg.	Pipe 1670mm	Tube 1670mm	Tubo 1670mm	Pijp 1670mm	Tubería de agua fría 1670mm	45

For:

Ersatzteilliste

Spare parts list

Liste des pièces de rechange

Lista parti di ricambio

Onderdelenlijst

Lista de repuestos

**SL 130-1 - 7719001195**

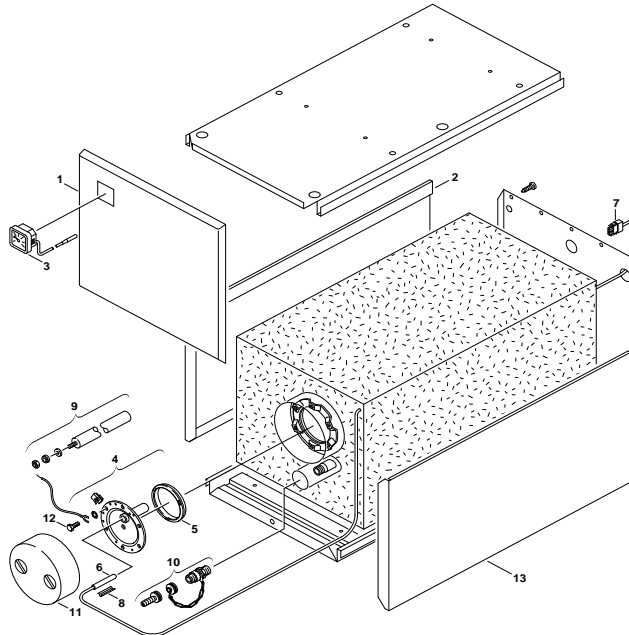

6720901214/G

Pos	Bestell-Nr.	Bezeichnung	Description	Dénomination	Descrizione	Benaming	Descripción	PG
1	8 729 010 745 0	Vorderwand	Cover	Couvercle	Coperchio	Voordeksel	Tapa	43
2	8 729 010 750 0	Seitenwand links weiß	Side panel left white	Côté droit blanc	Panello laterale sinistra bianco	Zijpaneel links wit	Pared lateral izquierda blanco	39
3	8 717 208 036 0	Thermometer	Thermometer	Thermomètre	Termometro	THERMOMETER SK...3Z-ST 110-E	Termómetro	37
4	8 715 503 341 0	Flansch	Flange	Bride de raccordement	Flangia	Aansluitflens	Brida de conexión	40
5	8 729 010 749 0	Dichtung	Washer	Joint	Guarnizione	Pakkingring	Junta	20
6	8 714 500 034 0	Sensor WW-NTC mit Aderendhülse 6m	Temperature sensor 6mm	SONDE DE TEMPERATURE 6mm	Sensore termometrico 6mm	Temperatuurvoeler 6mm	Sensor de temperatura 6mm	34
7	8 711 006 060 0	Stecker	Plug	Connecteur	Spina	STEKKER NTC-VOELER ST...1E/SK 300ST 75	Anection	16
8	8 711 200 005 0	Klemmfeder	Clamp spring	Ressort	Fermo	Haarspeldveer	Muelle de tecla	13
9	8 729 010 747 0	Anode	Anode	Anode	Anodo	Anode	Anodo	40
10	8 738 505 974 0	Ventil	Globe valve	Robinet	Valvola	AFSLUITKRAAN	Válvula de globo	26
11	8 729 010 752 0	Isolierung	Insulation	Isolation	Isolamento	Isolatie	Aislamiento	12
12	2 911 060 342 0	Schraube M12x30 (10x)	Screw M12x30 (10x)	Vis M12x30 (10x)	Vite M12x30 (10x)	Schroef M12x30 (10x)	Tornillo M12x30 (10x)	16
13	8 729 012 390 0	Seitenwand rechts weiß	Side panel right white	Côté droit blanc	Panello laterale a destra bianco	Zijpaneel rechts wit	Pared lateral derecha blanco	42
	8 713 401 046 0	Stellfuß	Foot	Pied	Vite	Voet	Pie	13
For:								

Ersatzteilliste  
Spare parts list  
Liste des pièces de rechange  
Lista parti di ricambio  
Onderdelenlijst  
Lista de repuestos

# SL 130-1/C 2 - 7719002039

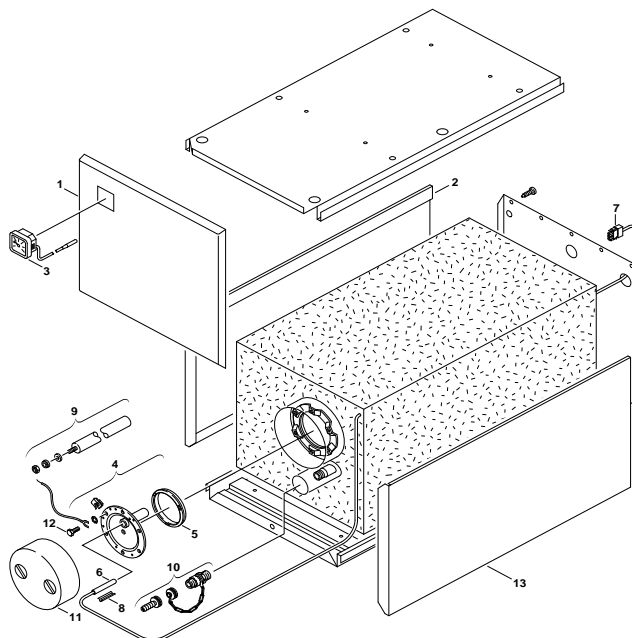

6720901214/G

Pos	Bestell-Nr.	Bezeichnung	Description	Dénomination	Descrizione	Benaming	Descripción	PG
1	8 729 012 335 0	Vorderwand silber	Cover silver	Couvercle argent	Coperchio argento	Voordeksel zilver	Tapa plata	43
2	8 729 012 337 0	Seitenwand links gelb	Side panel left yellow	Côté droit jaune	Pannelo laterale sinistra giallo	Zijpaneel links geel	Pared lateral izquierda amarillo	38
3	8 717 208 036 0	Thermometer	Thermometer	Thermomètre	Termometro	THERMOMETER SK...3Z-ST 110-E	Termómetro	37
4	8 715 503 341 0	Flansch	Flange	Bride de raccordement	Flangia	Aansluitflens	Brida de conexión	40
5	8 729 010 749 0	Dichtung	Washer	Joint	Guarnizione	Pakkingring	Junta	20
6	8 714 500 034 0	Sensor WW-NTC mit Aderendhülse 6m	Temperature sensor 6mm	SONDE DE TEMPERATURE 6mm	Sensore termometrico 6mm	Temperatuurvoeler 6mm	Sensor de temperatura 6mm	34
7	8 711 006 060 0	Stecker	Plug	Connecteur	Spina	STEKKER NTC-VOELER ST...1E/SK 300ST 75	Aneccion	16
8	8 711 200 005 0	Klemmfeder	Clamp spring	Ressort	Fermo	Haarspeldveer	Muelle de tecla	13
9	8 729 010 747 0	Anode	Anode	Anode	Anodo	Anode	Anodo	40
10	8 738 505 974 0	Ventil	Globe valve	Robinet	Valvola	AFSLUITKRAAN	Válvula de globo	26
11	8 729 010 752 0	Isolierung	Insulation	Isolation	Isolamento	Isolatie	Aislamiento	12
12	2 911 060 342 0	Schraube M12x30 (10x)	Screw M12x30 (10x)	Vis M12x30 (10x)	Vite M12x30 (10x)	Schroef M12x30 (10x)	Tornillo M12x30 (10x)	16
13	8 729 012 391 0	Seitenwand rechts gelb	Side panel right yellow	Côté droit jaune	Pannelo laterale a destra giallo	Zijpaneel rechts geel	Pared lateral derecha amarillo	42
	8 713 401 046 0	Stellfuß	Foot	Pied	Vite	Voet	Pie	13

For:

Ersatzteilliste  
 Spare parts list  
 Liste des pièces de rechange  
 Lista parti di ricambio  
 Onderdelenlijst  
 Lista de repuestos

# SL 200-1 - 7719001196

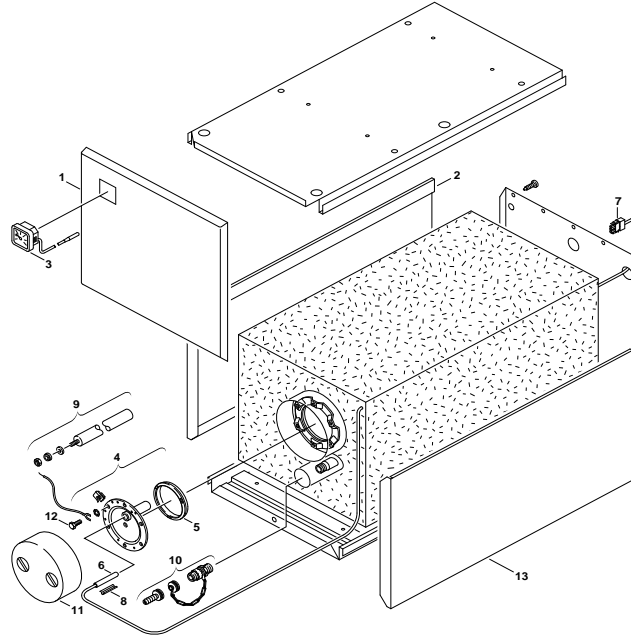

6720901214/G

Pos	Bestell-Nr.	Bezeichnung	Description	Dénomination	Descrizione	Benaming	Descripción	PG
1	8 729 010 745 0	Vorderwand	Cover	Couvercle	Coperchio	Voordeksel	Tapa	43
2	8 729 010 751 0	Seitenwand links weiß	Side panel left white	Côté droit blanc	Panello laterale sinistra bianco	Zijpaneel links wit	Pared lateral izquierda blanco	41
3	8 717 208 036 0	Thermometer	Thermometer	Thermomètre	Termometro	THERMOMETER SK...3Z-ST 110-E	Termómetro	37
4	8 715 503 341 0	Flansch	Flange	Bride de raccordement	Flangia	Aansluitflens	Brida de conexión	40
5	8 729 010 749 0	Dichtung	Washer	Joint	Guarnizione	Pakkingring	Junta	20
6	8 714 500 034 0	Sensor WW-NTC mit Aderendhülse 6m	Temperature sensor 6mm	SONDE DE TEMPERATURE 6mm	Sensore termometrico 6mm	Temperatuurvoeler 6mm	Sensor de temperatura 6mm	34
7	8 711 006 060 0	Stecker	Plug	Connecteur	Spina	STEKKER NTC-VOELER ST...1E/SK 300/ST 75	Anection	16
8	8 711 200 005 0	Klemmfeder	Clamp spring	Ressort	Fermo	Haarspeldveer	Muelle de tecla	13
9	8 729 010 748 0	Anode	Anode	Anode	Anodo	Anode	Anodo	40
10	8 738 505 974 0	Ventil	Globe valve	Robinet	Valvola	AFSLUITKRAAN	Válvula de globo	26
11	8 729 010 752 0	Isolierung	Insulation	Isolation	Isolamento	Isolatie	Aislamiento	12
12	2 911 060 342 0	Schraube M12x30 (10x)	Screw M12x30 (10x)	Vis M12x30 (10x)	Vite M12x30 (10x)	Schroef M12x30 (10x)	Tornillo M12x30 (10x)	16
13	8 729 012 392 0	Seitenwand rechts weiß	Side panel right white	Côté droit blanc	Panello laterale a destra bianco	Zijpaneel rechts wit	Pared lateral derecha blanco	47
	8 713 401 046 0	Stellfuß	Foot	Pied	Vite	Voet	Pie	13

For:

## Ersatzteilliste

Spare parts list

Liste des pièces de rechange

Lista parti di ricambio

Onderdelenlijst

Lista de repuestos

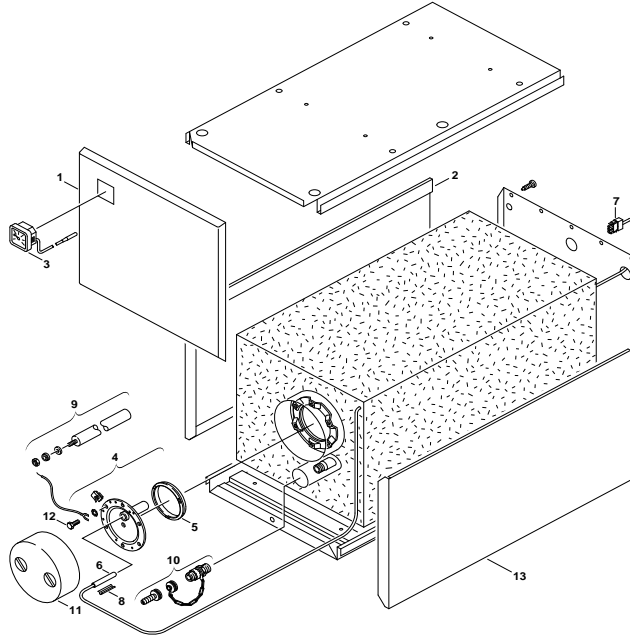
**SL 200-1/C 2 - 7719002040**

6720901214/G

Pos	Bestell-Nr.	Bezeichnung	Description	Dénomination	Descrizione	Benaming	Descripción	PG
1	<b>8 729 010 745 0</b>	Vorderwand	Cover	Couvercle	Coperchio	Voordeksel	Tapa	43
2	<b>8 729 012 340 0</b>	Seitenwand links gelb	Side panel left yellow	Côté droit jaune	Pannelo laterale sinistra giallo	Zijpaneel links geel	Pared lateral izquierda amarillo	42
3	<b>8 717 208 036 0</b>	Thermometer	Thermometer	Thermomètre	Termometro	THERMOMETER SK...3Z-ST 110-E	Termómetro	37
4	<b>8 715 503 341 0</b>	Flansch	Flange	Bride de raccordement	Flangia	Aansluitflens	Brida de conexión	40
5	<b>8 729 010 749 0</b>	Dichtung	Washer	Joint	Guarnizione	Pakkingring	Junta	20
6	<b>8 714 500 034 0</b>	Sensor WW-NTC mit Aderendhülse 6m	Temperature sensor 6mm	SONDE DE TEMPERATURE 6mm	Sensore termometrico 6mm	Temperatuurvoeler 6mm	Sensor de temperatura 6mm	34
7	<b>8 711 006 060 0</b>	Stecker	Plug	Connecteur	Spina	STEKKER NTC-VOELER ST...1E/SK 300/ST 75	Aneccion	16
8	<b>8 711 200 005 0</b>	Klemmfeder	Clamp spring	Ressort	Fermo	Haarspeldveer	Muelle de tecla	13
9	<b>8 729 010 748 0</b>	Anode	Anode	Anode	Anodo	Anode	Anodo	40
10	<b>8 738 505 974 0</b>	Ventil	Globe valve	Robinet	Valvola	AFSLUITKRAAN	Válvula de globo	26
11	<b>8 729 010 752 0</b>	Isolierung	Insulation	Isolation	Isolamento	Isolatie	Aislamiento	12
12	<b>2 911 060 342 0</b>	Schraube M12x30 (10x)	Screw M12x30 (10x)	Vis M12x30 (10x)	Vite M12x30 (10x)	Schroef M12x30 (10x)	Tornillo M12x30 (10x)	16
13	<b>8 729 012 393 0</b>	Seitenwand rechts gelb	Side panel right yellow	Côté droit jaune	Pannelo laterale a destra giallo	Zijpaneel rechts geel	Pared lateral derecha amarillo	47
	<b>8 713 401 046 0</b>	Stellfuß	Foot	Pied	Vite	Voet	Pie	13
For:								

Ersatzteilliste  
 Spare parts list  
 Liste des pièces de rechange  
 Lista parti di ricambio  
 Onderdelenlijst  
 Lista de repuestos

# SL130 - 7719000905

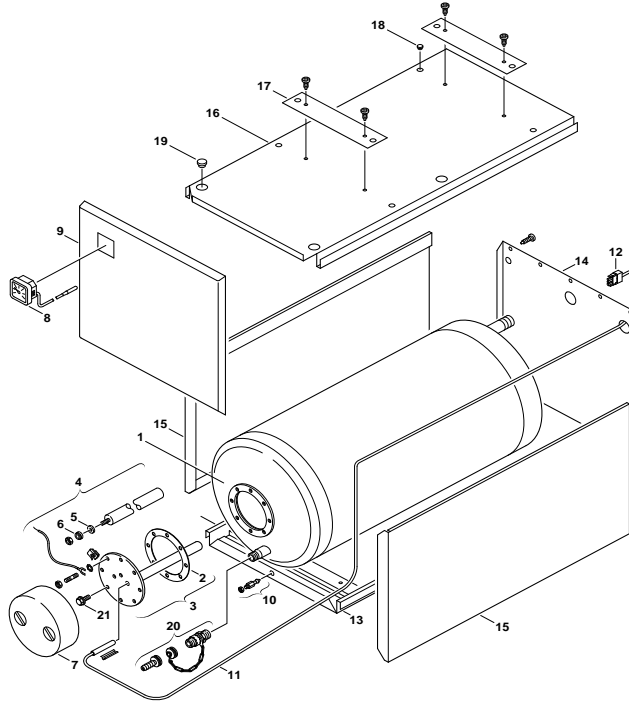

6720901212.AB/G

Pos	Bestell-Nr.	Bezeichnung	Description	Dénomination	Descrizione	Benaming	Descripción	PG
1	7 719 001 195	SL130-1 SPEICHER IND.	SL130-1 cylinder	SL130-1 Ballon	SL130-1 Accumulatore	SL130-1 Voorraadvat	SL130-1 Acumulador	
2	8 710 103 512 0	Dichtung	Washer	Joint	Guarnizione	DICHTING ST 110-E	Junta	19
3	8 715 705 056 0	Flansch	Connecting flange	Bride de raccordement	Flangia	Aansluitflens	Brida de conexión	46
4	8 719 918 767 0	Anode	Anode	Anode	Anodo	Anode	Anodo	41
5	8 710 103 113 0	Dichtung	Washer	Joint	Guarnizione	Pakkingring	Junta	19
6	8 710 303 034 0	Isolierung	Insulation	Isolation	Isolamento	Isolatie	Aislamiento	23
7	8 715 503 149 0	Abdeckung	Covering sheet	Couvercle	Coperchio	Afdichting	Chapa de protección	34
8	8 717 208 036 0	Thermometer	Thermometer	Thermomètre	Termometro	THERMOMETER SK...3Z-ST 110-E	Termómetro	37
9	8 718 005 413 0	Vorderwand	Cover	Couvercle	Coperchio	Voordeksel	Tapa	57
10	8 713 407 027 0	Verschlusssatz	Lock set	Sachet de serrure	Coperchio	Afsluitingsset	Conjunto cerradura	30
11	8 714 500 034 0	Sensor WW-NTC mit Aderendhülse 6m	Temperature sensor 6mm	SONDE DE TEMPERATURE 6mm	Sensore termometrico 6mm	Temperatuurvoeler 6mm	Sensor de temperatura 6mm	34
12	8 711 006 060 0	Stecker	Plug	Connecteur	Spina	STEKKER NTC-VOELER ST...1E/SK 300ST 75	Anection	16
13	8 718 005 411 0	Bodenblech	Oven bottom	Tôle de fond	Lamiera di fondo	Bodemplaat	Chapa de fondo	57
14	8 718 005 412 0	Rückwand	Backpanel	Dosseret	Schienale	Achterwand	Respaldo	55
15	8 718 005 409 0	Seitenteil	Side panel	Paroi latérale	Pannelo laterale	Zijpaneel	Lateral costado	52
16	8 718 005 410 0	Deckel	Cover	Couvercle	Coperchio	Deksel	Tapa	54
17	8 718 003 591 0	Befestigungsblech	Covering sheet	Tôle de protection	Copertura	Bevestigingsplaat	Chapa de protección	51
18	8 703 304 013 0	Stopfen Ø20mm	Grommet Ø20mm	Bouchon Ø20mm	Coperchietto Ø20mm	Doorvoertule Ø20mm	Tapon Ø20mm	31
20	8 738 505 974 0	Ventil	Globe valve	Robinet	Valvola	AFSLUITKRAAN	Válvula de globo	26
21	2 911 060 342 0	Schraube M12x30 (10x)	Screw M12x30 (10x)	Vis M12x30 (10x)	Vite M12x30 (10x)	Schroef M12x30 (10x)	Tornillo M12x30 (10x)	16

For:



Ersatzteilliste  
Spare parts list  
Liste des pièces de rechange  
Lista parti di ricambio  
Onderdelenlijst  
Lista de repuestos

**SL200 - 7719000906**

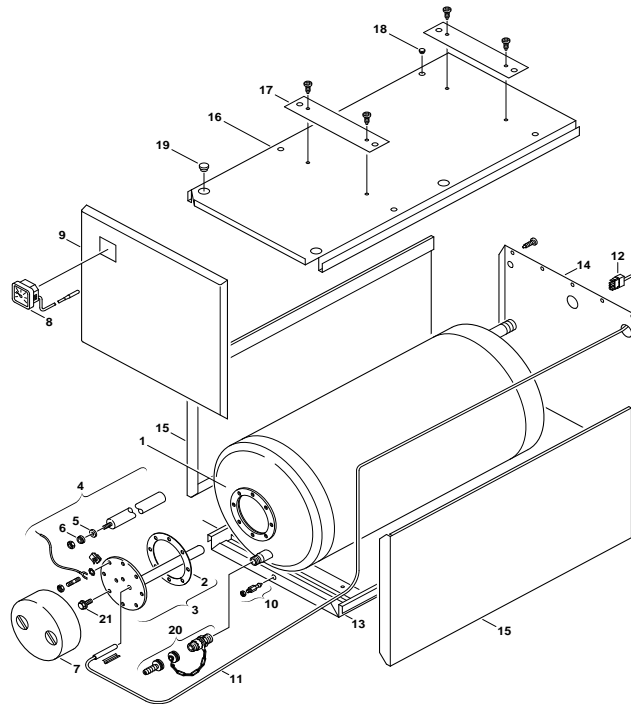

6720901212.AB/G

Pos	Bestell-Nr.	Bezeichnung	Description	Dénomination	Descrizione	Benaming	Descripción	PG
1	8 715 407 171 0	Behälter	Reservoir	Réipient	Sostegno	Reservoir	Déposito	82
2	8 710 103 512 0	Dichtung	Washer	Joint	Guarnizione	DICHTING ST 110-E	Junta	19
3	8 715 705 056 0	Flansch	Connecting flange	Bride de raccordement	Flangia	Aansluitflens	Brida de conexión	46
4	8 719 918 767 0	Anode	Anode	Anode	Anodo	Anode	Anodo	41
5	8 710 103 113 0	Dichtung	Washer	Joint	Guarnizione	Pakkingring	Junta	19
6	8 710 303 034 0	Isolierung	Insulation	Isolation	Isolamento	Isolatie	Aislamiento	23
7	8 715 503 149 0	Abdeckung	Covering sheet	Couvercle	Coperchio	Afdichting	Chapa de protección	34
8	8 717 208 036 0	Thermometer	Thermometer	Thermomètre	Termometro	THERMOMETER SK...3Z-ST 110-E	Termómetro	37
9	8 718 005 421 0	Vorderwand	Cover	Couvercle	Coperchio	Voordeksel	Tapa	58
10	8 713 407 027 0	Verschlusssatz	Lock set	Sachet de serrure	Coperchio	Afsluitingsset	Conjunto cerradura	30
11	8 714 500 034 0	Sensor WW-NTC mit Aderendhülse 6m	Temperature sensor 6mm	SONDE DE TEMPERATURE 6mm	Sensore termometrico 6mm	Temperatuurvoeler 6mm	Sensor de temperatura 6mm	34
12	8 711 006 060 0	Stecker	Plug	Connecteur	Spina	STEKKER NTC-VOELER ST...1E/SK 300/ST 75	Anection	16
13	8 718 005 419 0	Bodenblech	Oven bottom	Tôle de fond	Lamiera di fondo	Bodemplaat	Chapa de fondo	57
14	8 718 005 420 0	Rückwand	Backpanel	Dosseret	Schienale	Achterwand	Respaldo	55
15	8 718 005 417 0	Seitenteil	Side panel	Paroi latérale	Pannelo laterale	Zijpaneel	Lateral costado	53
16	8 718 005 418 0	Deckel	Cover	Couvercle	Coperchio	Deksel	Tapa	56
17	8 718 003 591 0	Befestigungsblech	Covering sheet	Tôle de protection	Copertura	Bevestigingsplaat	Chapa de protección	51
18	8 703 304 013 0	Stopfen Ø20mm	Grommet Ø20mm	Bouchon Ø20mm	Coperchietto Ø20mm	Doorvoertule Ø20mm	Tapon Ø20mm	31
20	8 738 505 974 0	Ventil	Globe valve	Robinet	Valvola	AFSLUITKRAAN	Válvula de globo	26
21	2 911 060 342 0	Schraube M12x30 (10x)	Screw M12x30 (10x)	Vis M12x30 (10x)	Vite M12x30 (10x)	Schroef M12x30 (10x)	Tornillo M12x30 (10x)	16

For:

**Ersatzteilliste**  
**Spare parts list**  
 Liste des pièces de rechange  
 Lista parti di ricambio  
 Onderdelenlijst  
 Lista de repuestos

# SO 120-1 - 7719001167

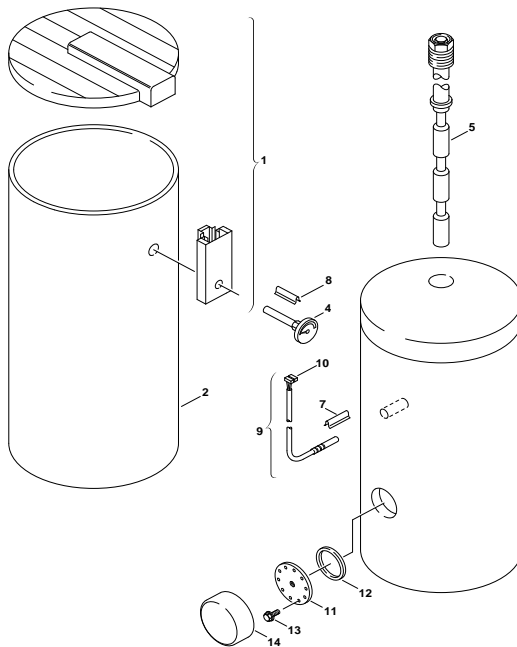

6720901211.AB/G

Pos	Bestell-Nr.	Bezeichnung	Description	Dénomination	Descrizione	Benaming	Descripción	PG
1	8 715 503 188 0	Haube hellgrau	Hood light grey	Capot gris clair	Coperchio grigio chiaro	DEKSEL SK 160-4ZB (VOOR BOILER 771900193)	Capota girar claro	42
2	8 715 401 254 0	Mantel weiß	Front shell white	Habillage blanc	Mantello bianco	Mantel wit	Carcasa blanco	46
4	8 717 208 050 0	Thermometer	Thermometer	Thermomètre	Termometro	Thermometer	Termómetro	31
5	8 709 918 505 0	Anode	Anode	Anode	Anodo	ANODE SO 120-SK 130/2Z-ST 120	Anodo	39
7	8 714 606 021 0	Klemmfeder	Clamp spring	Ressort	Fermo	KLEMVEER NTC SK120/140/160-4ZB	Muelle de tecla	25
8	8 714 606 024 0	Klemmfeder	Clamp spring	RESSORT POUR THERMOMETRE	Fermo	KLEMVEER V/THERMOMETER ST/SO	Muelle fijación	20
9	8 714 500 034 0	Sensor WW-NTC mit Aderendhülse 6m	Temperature sensor 6mm	SONDE DE TEMPERATURE 6mm	Sensore termometrico 6mm	Temperatuurvoeler 6mm	Sensor de temperatura 6mm	34
10	8 711 006 060 0	Stecker	Plug	Connecteur	Spina	STEKKER NTC-VOELER ST.-1E/SK 300/ST 75	Anection	16
	8 710 402 029 0	Kappe	panel	Capot de protection	Tappo	beschermkapje	tapa	20
For:								

Ersatzteilliste  
Spare parts list  
Liste des pièces de rechange  
Lista parti di ricambio  
Onderdelenlijst  
Lista de repuestos

# SO 120-1/C 2 - 7719002116

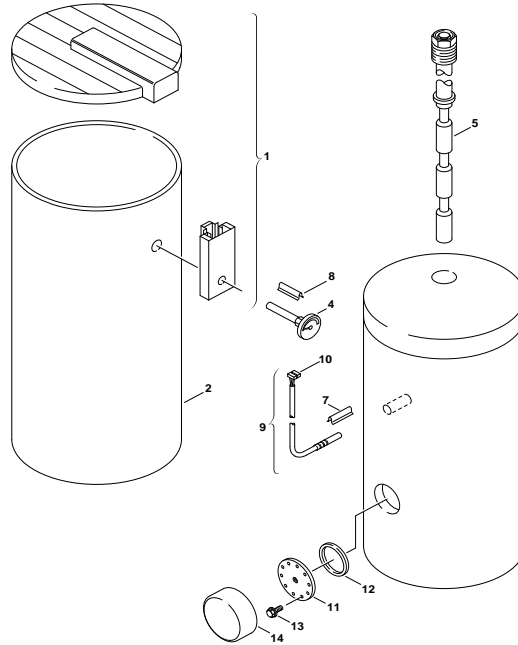

6720901211.AB/G

Pos	Bestell-Nr.	Bezeichnung	Description	Dénomination	Descrizione	Benaming	Descripción	PG
1	8 715 503 417 0	Haube silbergrau	Hood silver grey	Capot argent gris	Coperchio argentato grigio	Deksel zilvergrijs	Capota plata girar	42
2	8 715 401 384 0	Mantel Silber	Outer case silver	Habillage argent	Mantello argento	Mantel zilver	Carcasa plata	46
4	8 717 208 050 0	Thermometer	Thermometer	Thermomètre	Termometro	Thermometer	Termómetro	31
5	8 709 918 506 0	Anode	Anode	Anode	Anodo	<small>ANODE SO 160-160/1-200-200/1-SK 180-300-</small> Anodo	Anodo	43
7	8 714 606 021 0	Klemmfeder	Clamp spring	Ressort	Fermo	<small>KLEMVEER NTC SK120/140/160-4ZB</small> Muelle de tecla	Muelle de tecla	25
8	8 714 606 024 0	Klemmfeder	Clamp spring	<small>RESSORT POUR THERMOMETRE</small>	Fermo	<small>KLEMVEER V/THERMOMETER ST/SO</small> Muelle fijación	Muelle fijación	20
9	8 714 500 034 0	<small>Sensor WW-NTC mit Aderendhülse 6mm</small>	Temperature sensor 6mm	<small>SONDE DE TEMPERATURE 6mm</small>	Sensore termometrico 6mm	Temperatuurvoeler 6mm	Sensor de temperatura 6mm	34
10	8 711 006 060 0	Stecker	Plug	Connecteur	Spina	<small>STEKKER NTC-VOELER ST.-1E/SK 300/ST 75</small> Anection	Anection	16
	8 710 402 029 0	Kappe	panel	Capot de protection	Tappo	beschermkapje	tapa	20

For:

Ersatzteilliste  
 Spare parts list  
 Liste des pièces de rechange  
 Lista parti di ricambio  
 Onderdelenlijst  
 Lista de repuestos

**SO 160-1 - 7719001168**

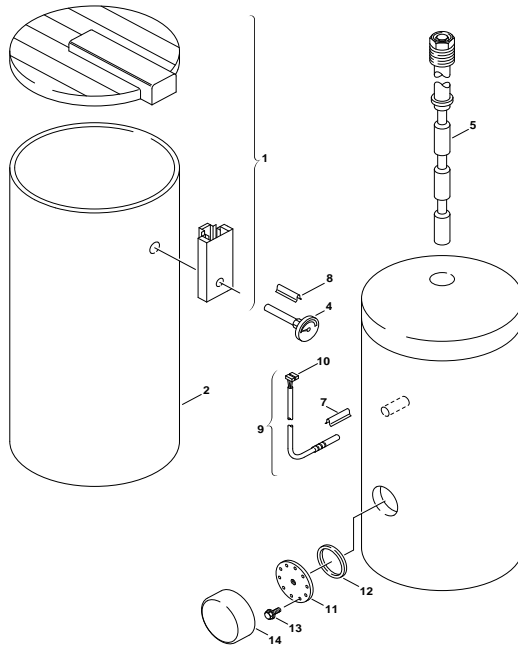

6720901211.AB/G

Pos	Bestell-Nr.	Bezeichnung	Description	Dénomination	Descrizione	Benaming	Descripción	PG
1	<b>8 715 503 188 0</b>	Haube hellgrau	Hood light grey	Capot gris clair	Coperchio grigio chiaro	DEKSEL SK 160-4ZB (VOOR BOILER 771900193)	Capota girar claro	42
2	<b>8 715 401 255 0</b>	Mantel weiß	Front shell white	Habillage blanc	Mantello bianco	Mantel wit	Carcasa blanco	49
4	<b>8 717 208 050 0</b>	Thermometer	Thermometer	Thermomètre	Termometro	Thermometer	Termómetro	31
5	<b>8 709 918 506 0</b>	Anode	Anode	Anode	Anodo	ANODE SO 160-160/1-200-200/1-SK 180-300-	Anodo	43
7	<b>8 714 606 021 0</b>	Klemmfeder	Clamp spring	Ressort	Fermo	KLEMVEER NTC SK120/140/160-4ZB	Muelle de tecla	25
8	<b>8 714 606 024 0</b>	Klemmfeder	Clamp spring	RESSORT POUR THERMOMETRE	Fermo	KLEMVEER V/THERMOMETER ST/SO	Muelle fijación	20
9	<b>8 714 500 034 0</b>	Sensor WW-NTC mit Aderendhülse 6mm	Temperature sensor 6mm	SONDE DE TEMPERATURE 6mm	Sensore termometrico 6mm	Temperatuurovoeler 6mm	Sensor de temperatura 6mm	34
10	<b>8 711 006 060 0</b>	Stecker	Plug	Connecteur	Spina	STEKKER NTC-VOELER ST...1E/SK 300/ST 75	Anection	16
	<b>8 710 402 029 0</b>	Kappe	panel	Capot de protection	Tappo	beschermkapje	tapa	20

For:

Ersatzteilliste  
 Spare parts list  
 Liste des pièces de rechange  
 Lista parti di ricambio  
 Onderdelenlijst  
 Lista de repuestos

**SO 160-1/C 2 - 7719002117**

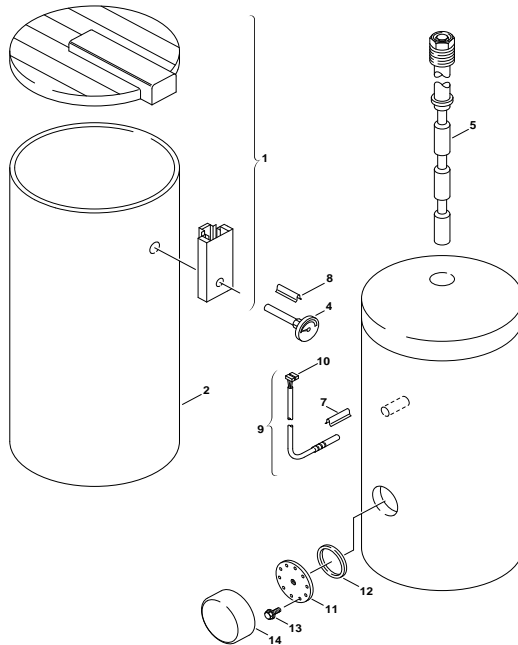

6720901211.AB/G

Pos	Bestell-Nr.	Bezeichnung	Description	Dénomination	Descrizione	Benaming	Descripción	PG
1	8 715 503 417 0	Haube silbergrau	Hood silver grey	Capot argent gris	Coperchio argentato grigio	Deksel zilvergrijs	Capota plata girar	42
2	8 715 401 385 0	Mantel silber	Outer_case silver	Habillage argent	Mantello argento	Mantel zilver	Carcasa plata	49
4	8 717 208 050 0	Thermometer	Thermometer	Thermomètre	Termometro	Thermometer	Termómetro	31
5	8 709 918 506 0	Anode	Anode	Anode	Anodo	ANODE SO 160-160/1-200-200/1-SK 180-300-	Anodo	43
7	8 714 606 021 0	Klemmfeder	Clamp spring	Ressort	Fermo	KLEMVEER NTC SK120/140/160-42B	Muelle de tecla	25
8	8 714 606 024 0	Klemmfeder	Clamp spring	RESSORT POUR THERMOMETRE	Fermo	KLEMVEER V/THERMOMETER ST/SO	Muelle fijación	20
9	8 714 500 034 0	Sensor WW-NTC mit Aderendhülse 6m	Temperature sensor 6mm	SONDE DE TEMPERATURE 6mm	Sensore termometrico 6mm	Temperatuurvoeler 6mm	Sensor de temperatura 6mm	34
10	8 711 006 060 0	Stecker	Plug	Connecteur	Spina	STEKKER NTC-VOELER ST.-1/ESK 300/ST 75	Anection	16
	8 710 402 029 0	Kappe	panel	Capot de protection	Tappo	beschermkapje	tapa	20

For:

Ersatzteilliste  
Spare parts list  
Liste des pièces de rechange  
Lista parti di ricambio  
Onderdelenlijst  
Lista de repuestos

**SO 200-1 - 7719001169**

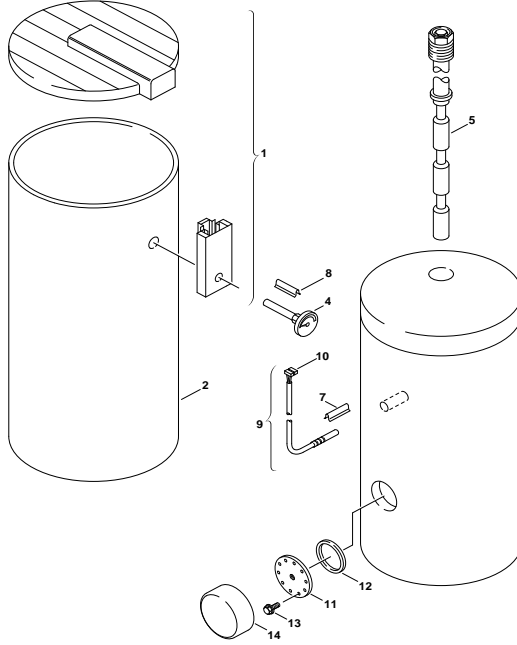

6720901211.AB/G

Pos	Bestell-Nr.	Bezeichnung	Description	Dénomination	Descrizione	Benaming	Descripción	PG
1	8 715 503 188 0	Haube hellgrau	Hood light grey	Carpot gris clair	Coperchio grigio chiaro	DEKSEL SK 160-4ZB (VOOR BOILER 7719001169)	Capota girar claro	42
2	8 715 401 256 0	Mantel weiß	Front shell white	Habillage blanc	Mantello bianco	Mantel wit	Carcasa blanco	49
4	8 717 208 050 0	Thermometer	Thermometer	Thermomètre	Termometro	Thermometer	Termómetro	31
5	8 709 918 506 0	Anode	Anode	Anode	Anodo	ANODE SO 160-160/1-200-200/1-SK 180-300-	Anodo	43
7	8 714 606 021 0	Klemmfeder	Clamp spring	Ressort	Fermo	KLEMVEER NTC SK120/140/160-4ZB	Muelle de tecla	25
8	8 714 606 024 0	Klemmfeder	Clamp spring	RESSORT POUR THERMOMETRE	Fermo	KLEMVEER V/THERMOMETER ST/SO	Muelle fijación	20
9	8 714 500 034 0	Sensor WW-NTC mit Aderendhülse 6m	Temperature sensor 6mm	SONDE DE TEMPERATURE 6mm	Sensore termometrico 6mm	Temperatuurvoeler 6mm	Sensor de temperatura 6mm	34
10	8 711 006 060 0	Stecker	Plug	Connecteur	Spina	STEKKER NTC-VOELER ST...1ESK 300ST 75	Anection	16
	8 710 402 029 0	Kappe	panel	Capot de protection	Tappo	beschermkapje	tapa	20

For:

## Ersatzteilliste

Spare parts list

Liste des pièces de rechange

Lista parti di ricambio

Onderdelenlijst

Lista de repuestos

SO 200-1/C 2 - 7719002118

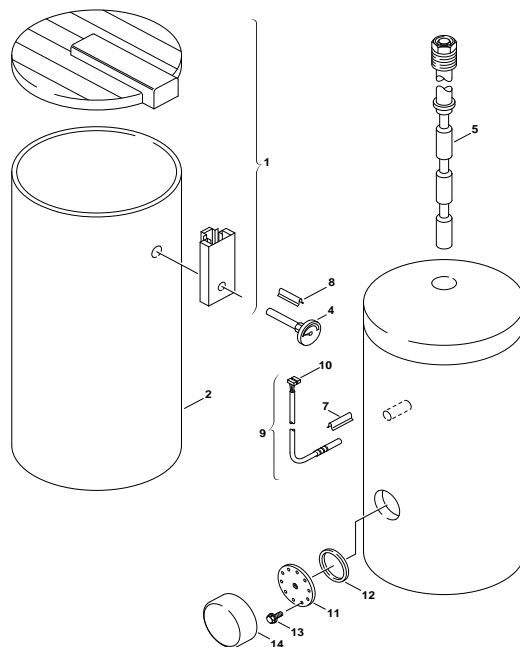

6720901211.AB/G

Pos	Bestell-Nr.	Bezeichnung	Description	Dénomination	Descrizione	Benaming	Descripción	PG
1	8 715 503 417 0	Haube silbergrau	Hood silver grey	Capot argent gris	Coperchio argentato grigio	Deksel zilvergrijs	Capota plata girar	42
2	8 715 401 386 0	Mantel silber	Front shell silver	Habillage argent	Mantello argento	Mantel zilver	Carcasa plata	49
4	8 717 208 050 0	Thermometer	Thermometer	Thermomètre	Termometro	Thermometer	Termómetro	31
5	8 709 918 506 0	Anode	Anode	Anode	Anodo	ANODE SO 160-160/1-200-200/1-SK 180-300-	Anodo	43
7	8 714 606 021 0	Klemmfeder	Clamp spring	Ressort	Fermo	KLEMVEER NTC SK120/140/160-4ZB	Muelle de tecla	25
8	8 714 606 024 0	Klemmfeder	Clamp spring	RESSORT POUR THERMOMETRE	Fermo	KLEMVEER V/THERMOMETER ST/SO	Muelle fijación	20
9	8 714 500 034 0	Sensor WW-NTC mit Aderendhülse 6mm	Temperature sensor 6mm	SONDE DE TEMPERATURE 6mm	Sensore termometrico 6mm	Temperatuurvoeler 6mm	Sensor de temperatura 6mm	34
10	8 711 006 060 0	Stecker	Plug	Connecteur	Spina	STEKKER NTC-VOELER ST.-1/ESK 300/ST 75	Anection	16
	8 710 402 029 0	Kappe	panel	Capot de protection	Tappo	beschermkapje	tapa	20

For:







**Ersatzteilliste**  
**Spare parts list**  
**Liste des pièces de rechange**  
**Lista parti di ricambio**  
**Onderdelenlijst**  
**Lista de repuestos**

**SO120-1S3500 - 7719001448**

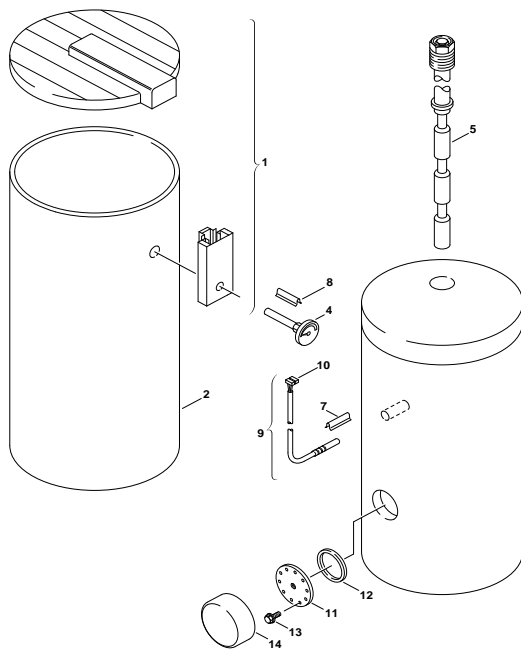

6720901211.AB/G

Pos	Bestell-Nr.	Bezeichnung	Description	Dénomination	Descrizione	Benaming	Descripción	PG
1	8 715 503 188 0	Haube hellgrau	Hood light grey	Carpot gris clair	Coperchio grigio chiaro	<small>DEKSEL SK 160-42B (VOOR BOILER 771900193)</small>	Capota girar claro	42
2	8 715 401 254 0	Mantel weiß	Front shell white	Habillage blanc	Mantello bianco	Mantel wit	Carcasa blanco	46
4	8 717 208 050 0	Thermometer	Thermometer	Thermomètre	Termometro	Thermometer	Termómetro	31
5	8 709 918 506 0	Anode	Anode	Anode	Anodo	<small>ANODE SO 160-160/1-200-200/1-SK 160-300-</small>	Anodo	43
7	8 714 606 021 0	Klemmfeder	Clamp spring	Ressort	Fermo	<small>KLEMVEER NTC SK120/140/160-42B</small>	Muelle de tecla	25
8	8 714 606 024 0	Klemmfeder	Clamp spring	<small>RESSORT POUR THERMOMETRE</small>	Fermo	<small>KLEMVEER V/THERMOMETER ST/SO</small>	Muelle fijación	20
9	8 714 500 034 0	<small>Sensor WW-NTC mit Aderendhülse 6mm</small>	Temperature sensor 6mm	<small>SONDE DE TEMPERATURE 6mm</small>	Senore termometrico 6mm	<small>Temperatuurvoeler 6mm</small>	Sensor de temperatura 6mm	34
10	8 711 006 060 0	Stecker	Plug	Connecteur	Spina	<small>STEKKER NTC-VOELER ST...1E/SK 300/ST 75</small>	Anection	16
	7 709 500 048	Rückschlagventil 3/4"	Non-return valve 3/4"	Soupape de non-retour 3/4"	Valvola di non ritorno 3/4"	<b>Terugslagklep 3/4"</b>	válvula de retención 3/4"	
	7 709 500 052	Überdruckventil 1/2*3/4" 10 bar	VÁLVULA SEG. 1/2*3/4" 10 bar	VÁLVULA SEG. 1/2*3/4" 10 bar	Valvola di sovrappressione 1/2*3/4"10 bar	Overdrukveiligheid 1/2*3/4" 10 bar	VÁLVULA SEG. 1/2*3/4" 10 bar	
	8 710 402 029 0	Kappe	panel	Capot de protection	Tappo	beschermkapje	tapa	20
For:								

Ersatzteilliste  
Spare parts list  
Liste des pièces de rechange  
Lista parti di ricambio  
Onderdelenlijst  
Lista de repuestos

SO160 - 7719000712

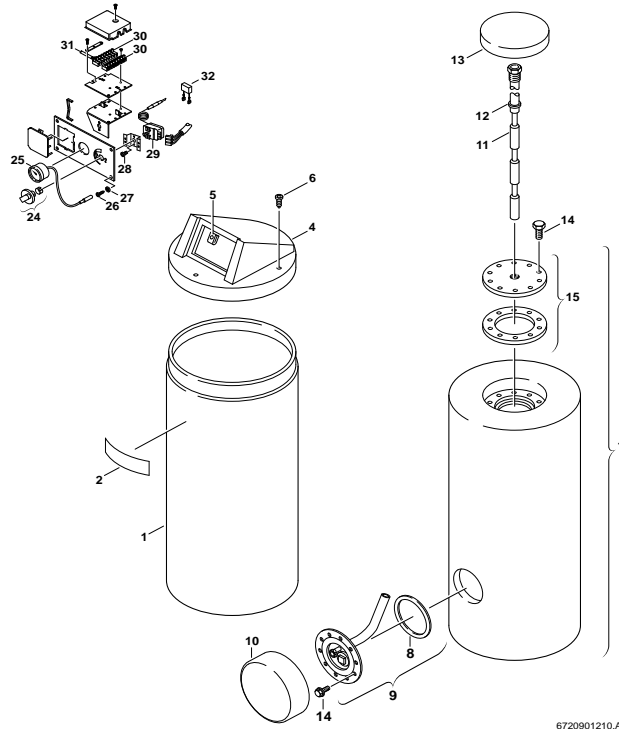

6720901210.AC/G

Pos	Bestell-Nr.	Bezeichnung	Description	Dénomination	Descrizione	Benaming	Descripción	PG
1	8 715 401 125 0	Mantel	Outer_case	Habillage	Mantello	Mantel	Carcasa	46
4	8 718 006 435 0	Deckel	Cover	Couvercle	Coperchio	Deksel	Tapa	39
5	8 713 309 026 0	Mutter (10x)	Nut	Ecrou (10x)	Dado (10x)	Moer (10x)	Tuerca (10x)	12
6	8 713 403 008 0	Schraube (10x)	Screw	Vis (10x)	Vite (10x)	Schroef (10x)	Tornillo (10x)	11
11	8 709 918 506 0	Anode	Anode	Anode	Anodo	ANODE SO 160-160/1-200-200/1-SK 180-300-	Anodo	43
12	8 710 103 086 0	Dichtscheibe (10x)	Washer (10x)	Joint (10x)	Guarnizione (10x)	DICHTING ANODE VOOR SO 160	Junta (10x)	22
13	8 718 006 397 0	Isolierung	Insulation	Isolation	Isolamento	Isolatie	Aislamiento	23
24	8 712 000 034 0	Drehknopf	Rotary handle	Bouton de réglage	Manopola	Regelknop	Botón rotativo	12
25	8 737 208 991 0	Thermometer	Thermometer	Thermomètre	Termometro	THERMOMETER SO...SK...22-32 - Z(W)... F	Termómetro	37
26	8 713 403 008 0	Schraube (10x)	Screw	Vis (10x)	Vite (10x)	Schroef (10x)	Tornillo (10x)	11
27	2 916 030 006 0	Sicherungsscheibe (10x)	Retaining ring (10x)	Circlips (10x)	Rondella (10x)	BORGRING UIT TTB 771900055P	Arandela de seguridad (10x)	11
29	8 717 206 186 0	Temperaturregler	Flow thermostat	Thermostat	Thermostat	AQUASTAAT MWISSELKONTAKT SO 120-160-200	Regulador de temperatura	36
30	8 711 006 046 0	Klemmleiste 24V	Terminal strip 24V	Bornier 24V	Cablaggio 24V	Klemmenstrook 24V	Regleta de bornes 24V	08
31	8 714 401 396 0	Kabel	Cable	Faisceau	Cablaggio	Kabel	Cable	23
32	8 717 301 017 0	Entstörkondensator	ENTSTÖRKONDENSATOR	Condensateur	Condensatore	CONDENSATOR VOOR AQUASTAAT 8 737 206 974	Condensador filtro	14

For:

Ersatzteilliste  
 Spare parts list  
 Liste des pièces de rechange  
 Lista parti di ricambio  
 Onderdelenlijst  
 Lista de repuestos

SO160-1 - 7719002875

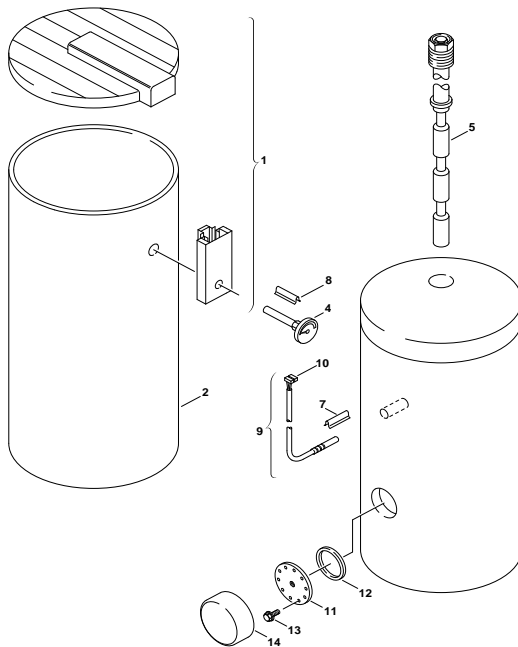

6720901211.AB/G

Pos	Bestell-Nr.	Bezeichnung	Description	Dénomination	Descrizione	Benaming	Descripción	PG
1	8 715 503 188 0	Haube hellgrau	Hood light grey	Carpot gris clair	Coperchio grigio chiaro	DEKSEL SK 160-4ZB (VOOR BOILER 771900193	Capota girar claro	42
2	8 715 401 255 0	Mantel weiß	Front shell white	Habillage blanc	Mantello bianco	Mantel wit	Carcasa blanco	49
4	8 717 208 050 0	Thermometer	Thermometer	Thermomètre	Termometro	Thermometer	Termómetro	31
5	8 709 918 506 0	Anode	Anode	Anode	Anodo	ANODE SO 160-160/1-200-200/1-SK 160-300-	Anodo	43
7	8 714 606 021 0	Klemmfeder	Clamp spring	Ressort	Fermo	KLEMVEER NTC SK120/140/160-4ZB	Muelle de tecla	25
8	8 714 606 024 0	Klemmfeder	Clamp spring	RESSORT POUR THERMOMETRE	Fermo	KLEMVEER V/THERMOMETER ST/SO	Muelle fijación	20
9	8 714 500 034 0	Sensor WW-NTC mit Aderendhülse 6mm	Temperature sensor 6mm	SONDE DE TEMPERATURE 6mm	Sensore termometrico 6mm	Temperatuurvoeler 6mm	Sensor de temperatura 6mm	34
10	8 711 006 060 0	Stecker	Plug	Connecteur	Spina	STEKKER NTC-VOELER ST.-1E/SK 300/ST 75	Anection	16
	8 710 402 029 0	Kappe	panel	Capot de protection	Tappo	beschermkapje	tapa	20

For:



Ersatzteilliste  
 Spare parts list  
 Liste des pièces de rechange  
 Lista parti di ricambio  
 Onderdelenlijst  
 Lista de repuestos

# SO160-1BS3500 - 7719001477

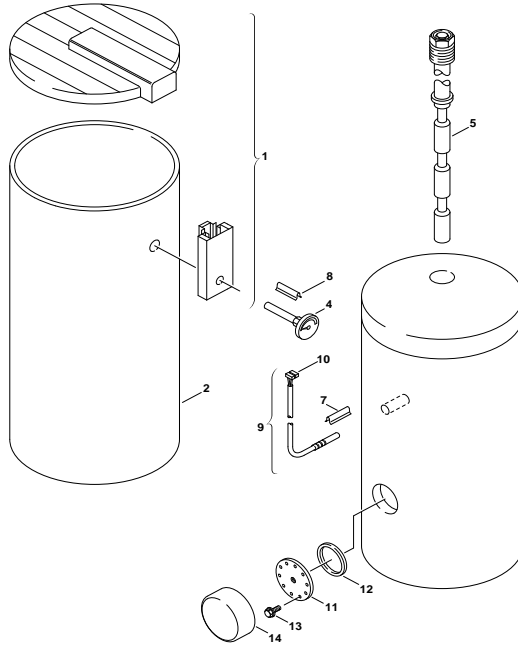

6720901211.AB/G

Pos	Bestell-Nr.	Bezeichnung	Description	Dénomination	Descrizione	Benaming	Descripción	PG
1	8 715 503 188 0	Haube hellgrau	Hood light grey	Carpot gris clair	Coperchio grigio chiaro	DEKSEL SK 160-4ZB (VOOR BOILER 771900193)	Capota girar claro	42
2	8 715 401 255 0	Mantel weiß	Front shell white	Habillage blanc	Mantello bianco	Mantel wit	Carcasa blanco	49
4	8 717 208 050 0	Thermometer	Thermometer	Thermomètre	Termometro	Thermometer	Termómetro	31
5	8 709 918 506 0	Anode	Anode	Anode	Anodo	ANODE SO 160-160/1-200-200/1-SK 180-300-	Anodo	43
7	8 714 606 021 0	Klemmfeder	Clamp spring	Ressort	Fermo	KLEMVEER NTC SK120/140/160-4ZB	Muelle de tecla	25
8	8 714 606 024 0	Klemmfeder	Clamp spring	RESSORT POUR THERMOMETRE	Fermo	KLEMVEER V/THERMOMETRE ST/SO	Muelle fijación	20
9	8 714 500 034 0	Sensor WW-NTC mit Aderendhülse 6m	Temperature sensor 6mm	SONDE DE TEMPERATURE 6mm	Sensore termometrico 6mm	Temperatuurvoeler 6mm	Sensor de temperatura 6mm	34
10	8 711 006 060 0	Stecker	Plug	Connecteur	Spina	STEKKER NTC-VOELER ST...1E/SK 300/ST 75	Anection	16
11	8 715 503 170 0	Flansch mit Tauchrohr kpl.	Connecting flange	Bride de raccordement	Flangia	FLENS + DICHTING SK - 3ZB	Conjunto brida y junta SK500	40
12	8 710 103 096 0	Dichtungs-Set 100x109D - 115/138Dx3 (1x)	Set of seals 100x109D - 115/138Dx3 (1x)	Jeu de joints 100x109D - 115/138Dx3 (1x)	Set guarnizioni 100x109D - 115/138Dx3	DICHTING FLENS SK..2ZB-3ZB (VANAF 070)	conjunto de juntas 100x109D - 115/138Dx3	23
14	8 718 006 637 0	Abdeckung grau	Covering sheet grey	Couvercle gris	Coperchio grigio	Afdichting grijs	Chapa de protección girar	35
	8 710 402 029 0	Kappe	panel	Capot de protection	Tappo	beschermkapje	tapa	20
For:								

Ersatzteilliste  
 Spare parts list  
 Liste des pièces de rechange  
 Lista parti di ricambio  
 Onderdelenlijst  
 Lista de repuestos

# SO160-1S3500 - 7719001449

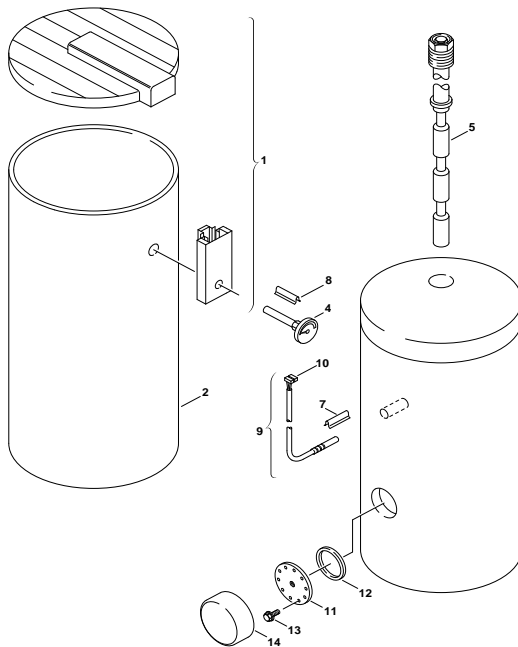

6720901211.AB/G

Pos	Bestell-Nr.	Bezeichnung	Description	Dénomination	Descrizione	Benaming	Descripción	PG
1	8 715 503 188 0	Haube hellgrau	Hood light grey	Carpot gris clair	Coperchio grigio chiaro	DEKSEL SK 160-42B (VOOR BOILER 771900193)	Capota girar claro	42
2	8 715 401 255 0	Mantel weiß	Front shell white	Habillage blanc	Mantello bianco	Mantel wit	Carcasa blanco	49
4	8 717 208 050 0	Thermometer	Thermometer	Thermomètre	Termometro	Thermometer	Termómetro	31
5	8 709 918 506 0	Anode	Anode	Anode	Anodo	ANODE SO 160-160/1-200-200/1-SK 160-300-	Anodo	43
7	8 714 606 021 0	Klemmfeder	Clamp spring	Ressort	Fermo	KLEMVEER NTC SK120/140/160-42B	Muelle de tecla	25
8	8 714 606 024 0	Klemmfeder	Clamp spring	RESSORT POUR THERMOMETRE	Fermo	KLEMVEER V/THERMOMETER ST/SO	Muelle fijación	20
9	8 714 500 034 0	Sensor WW-NTC mit Aderendhülse 6mm	Temperature sensor 6mm	SONDE DE TEMPERATURE 6mm	Sensore termometrico 6mm	Temperatuurvoeler 6mm	Sensor de temperatura 6mm	34
10	8 711 006 060 0	Stecker	Plug	Connecteur	Spina	STEKKER NTC-VOELER ST.-1E/SK 300/ST 75	Anection	16
	7 709 500 048	Rückschlagventil 3/4"	Non-return valve 3/4"	Soupape de non-retour 3/4"	Valvola di non ritorno 3/4"	Terugslagklep 3/4"	válvula de retención 3/4"	
	7 709 500 052	Überdruckventil 1/2*3/4" 10 bar	VÁLVULA SEG. 1/2*3/4" 10 bar	VÁLVULA SEG. 1/2*3/4" 10 bar	Valvola di sovrappressione 1/2*3/4"10 bar	Overdrukvelligheid 1/2*3/4" 10 bar	VÁLVULA SEG. 1/2*3/4" 10 bar	
	8 710 402 029 0	Kappe	panel	Capot de protection	Tappo	beschermkapje	tapa	20

For:

Ersatzteilliste  
Spare parts list  
Liste des pièces de rechange  
Lista parti di ricambio  
Onderdelenlijst  
Lista de repuestos

SO160B - 7719000776

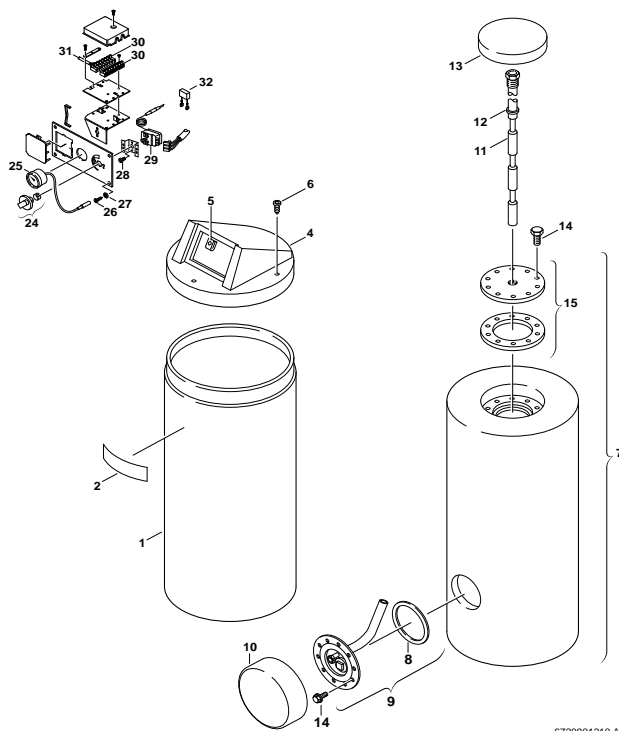

Pos	Bestell-Nr.	Bezeichnung	Description	Dénomination	Descrizione	Benaming	Descripción	PG
1	8 715 401 125 0	Mantel	Outer_case	Habillage	Mantello	Mantel	Carcasa	46
4	8 718 006 435 0	Deckel	Cover	Couvercle	Coperchio	Deksel	Tapa	39
5	8 713 309 026 0	Mutter (10x)	Nut	Ecrou (10x)	Dado (10x)	Moer (10x)	Tuerca (10x)	12
6	8 713 403 008 0	Schraube (10x)	Screw	Vis (10x)	Vite (10x)	Schroef (10x)	Tornillo (10x)	11
7	8 715 407 057 0	Behälter	Reservoir	Récipient	Sostegno	Reservoir	Déposito	65
8	8 710 103 096 0	Dichtungs-Set 100x109D - 115/138Dx3 (1x)	Set of seals 100x109D - 115/138Dx3 (1x)	Jeu de joints 100x109D - 115/138Dx3 (1x)	Set guarnizioni 100x109D - 115/138Dx3	DICHTING FLENS SK...ZZB-3ZB (VANAF 070	conjunto de juntas 100x109D - 115/138Dx3	23
9	8 715 503 170 0	Flansch mit Tauchrohr kpl.	Connecting flange	Bride de raccordement	Flangia	FLENS + DICHTING SK - 3ZB	Conjunto brida y junta SK500	40
10	8 718 006 541 0	Abdeckung	Covering sheet	Couvercle	Coperchio	Afdichting	Chapa de protección	22
11	8 709 918 506 0	Anode	Anode	Anode	Anodo	ANODE SO 160-160/1-200-2001-SK 180-300-	Anodo	43
12	8 710 103 086 0	Dichtscheibe (10x)	Washer (10x)	Joint (10x)	Guarnizione (10x)	DICHTING ANODE VOOR SO 160	Junta (10x)	22
13	8 718 006 397 0	Isolierung	Insulation	Isolation	Isolamento	Isolatie	Aislamiento	23
14	2 911 060 342 0	Schraube M12x30 (10x)	Screw M12x30 (10x)	Vis M12x30 (10x)	Vite M12x30 (10x)	Schroef M12x30 (10x)	Tornillo M12x30 (10x)	16
24	8 712 000 034 0	Drehknopf	Rotary handle	Bouton de réglage	Manopola	Regelknop	Botón rotativo	12
25	8 737 208 991 0	Thermometer	Thermometer	Thermomètre	Termometro	THERMOMETER SO...SK...ZZ-3Z - Z(W)...F	Termómetro	37
26	8 713 403 008 0	Schraube (10x)	Screw	Vis (10x)	Vite (10x)	Schroef (10x)	Tornillo (10x)	11
27	2 916 030 006 0	Sicherungsscheibe (10x)	Retaining ring (10x)	Circlips (10x)	Rondella (10x)	BORGRING UIT TTB 771900055P	Arandela de seguridad (10x)	11
29	8 717 206 186 0	Temperaturregler	Flow thermostat	Thermostat	Thermostat	AQUASTAAT MWISSELKONTAKT SO 120-160-200	Regulador de temperatura	36
30	8 711 006 046 0	Klemmleiste 24V	Terminal strip 24V	Bornier 24V	Cablaggio 24V	Klemmenstrook 24V	Regleta de bornes 24V	08
31	8 714 401 396 0	Kabel	Cable	Faisceau	Cablaggio	Kabel	Cable	23
32	8 717 301 017 0	Entstörkondensator	ENTSTÖRKONDENSATOR	Condensateur	Condensatore	CONDENSATOR VOOR AQUASTAAT 8 737 206 974	Condensador filtro	14

For:



Ersatzteilliste  
 Spare parts list  
 Liste des pièces de rechange  
 Lista parti di ricambio  
 Onderdelenlijst  
 Lista de repuestos

**SO200 - 7719000713**

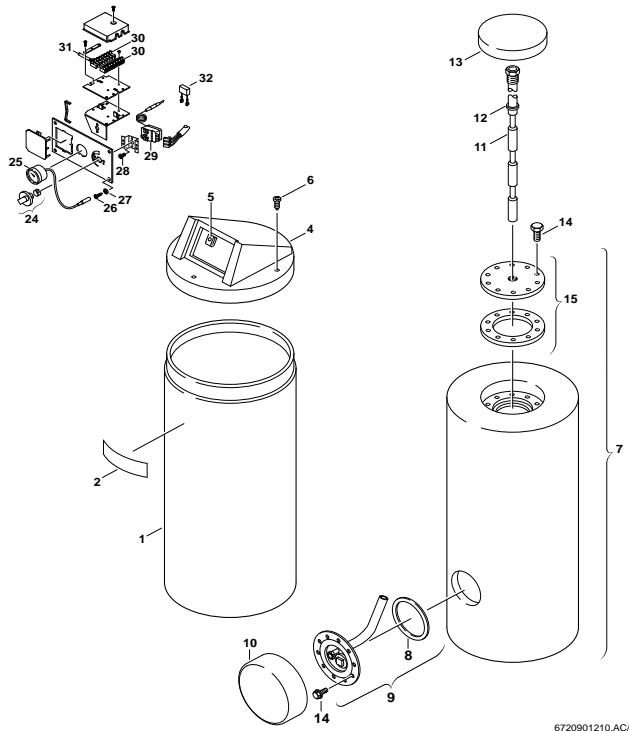

Pos	Bestell-Nr.	Bezeichnung	Description	Dénomination	Descrizione	Benaming	Descripción	PG
1	8 715 401 126 0	Mantel	Shell	Habillage	Mantello	Mantel	Carcasa	47
4	8 718 006 435 0	Deckel	Cover	Couvercle	Coperchio	Deksel	Tapa	39
5	8 713 309 026 0	Mutter (10x)	Nut	Ecrou (10x)	Dado (10x)	Moer (10x)	Tuerca (10x)	12
6	8 713 403 008 0	Schraube (10x)	Screw	Vis (10x)	Vite (10x)	Schroef (10x)	Tornillo (10x)	11
7	8 715 407 047 0	Behälter	Reservoir	Réipient	Sostegno	Reservoir	Déposito	66
11	8 709 918 506 0	Anode	Anode	Anode	Anodo	ANODE SO 160-1601-200-2001-SK 160-300-	Anodo	43
12	8 710 103 086 0	Dichtscheibe (10x)	Washer (10x)	Joint (10x)	Guarnizione (10x)	DICHTING ANODE VOOR SO 160	Junta (10x)	22
13	8 718 006 397 0	Isolierung	Insulation	Isolation	Isolamento	Isolatie	Aislamiento	23
24	8 712 000 034 0	Drehknopf	Rotary handle	Bouton de réglage	Manopola	Regelknop	Botón rotativo	12
25	8 737 208 991 0	Thermometer	Thermometer	Thermomètre	Termometro	THERMOMETER SO...SK...-22-32-Z(W)...F	Termómetro	37
26	8 713 403 008 0	Schraube (10x)	Screw	Vis (10x)	Vite (10x)	Schroef (10x)	Tornillo (10x)	11
27	2 916 030 006 0	Sicherungsscheibe (10x)	Retaining ring (10x)	Circlips (10x)	Rondella (10x)	BORGRING UIT TTB 771900055P	Arandela de seguridad (10x)	11
29	8 717 206 186 0	Temperaturregler	Flow thermostat	Thermostat	Termostat	AQUASTAAT MWISSELKONTAKT SO 120-160-200	Regulador de temperatura	36
30	8 711 006 046 0	Klemmleiste 24V	Terminal strip 24V	Bornier 24V	Cablaggio 24V	Klemmenstrook 24V	Regleta de bornes 24V	08
31	8 714 401 396 0	Kabel	Cable	Faisceau	Cablaggio	Kabel	Cable	23
32	8 717 301 017 0	Entstörkondensator	ENTSTÖRKONDENSATOR	Condensateur	Condensatore	CONDENSATOR VOOR AQUASTAAT 8 737 206 974	Condensador filtro	14
For:								

Ersatzteilliste  
Spare parts list  
Liste des pièces de rechange  
Lista parti di ricambio  
Onderdelenlijst  
Lista de repuestos

# SO200-1 - 7719002876

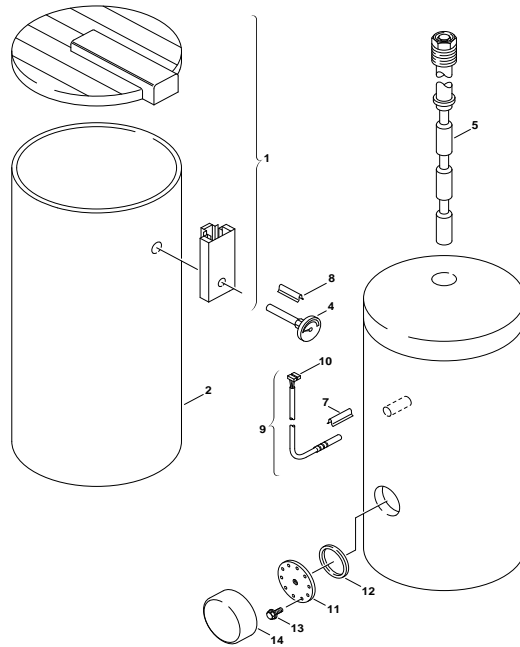

6720901211.AB/G

Pos	Bestell-Nr.	Bezeichnung	Description	Dénomination	Descrizione	Benaming	Descripción	PG
1	8 715 503 188 0	Haube hellgrau	Hood light grey	Capot gris clair	Coperchio grigio chiaro	DEKSEL SK 160-4ZB (VOOR BOILER 771900193)	Capota girar claro	42
2	8 715 401 256 0	Mantel weiß	Front shell white	Habillage blanc	Mantello bianco	Mantel wit	Carcasa blanco	49
4	8 717 208 050 0	Thermometer	Thermometer	Thermomètre	Termometro	Thermometer	Termómetro	31
5	8 709 918 506 0	Anode	Anode	Anode	Anodo	ANODE SO 160-160/1-200-200/1-SK 160-300-	Anodo	43
7	8 714 606 021 0	Klemmfeder	Clamp spring	Ressort	Fermo	KLEMVEER NTC SK120/140/160-4ZB	Muelle de tecla	25
8	8 714 606 024 0	Klemmfeder	Clamp spring	RESSORT POUR THERMOMETRE	Fermo	KLEMVEER V/THERMOMETER ST/SO	Muelle fijación	20
9	8 714 500 034 0	Sensor WW-NTC mit Aderendhülse 6mm	Temperature sensor 6mm	SONDE DE TEMPERATURE 6mm	Sensore termometrico 6mm	Temperatuurvoeler 6mm	Sensor de temperatura 6mm	34
10	8 711 006 060 0	Stecker	Plug	Connecteur	Spina	STEKKER NTC-VOELER ST.-1/ESK 300/ST 75	Anection	16
	8 710 402 029 0	Kappe	panel	Capot de protection	Tappo	beschermkapje	tapa	20

For:

Ersatzteilliste  
Spare parts list  
Liste des pièces de rechange  
Lista parti di ricambio  
Onderdelenlijst  
Lista de repuestos

# SO200-1B - 7719001171

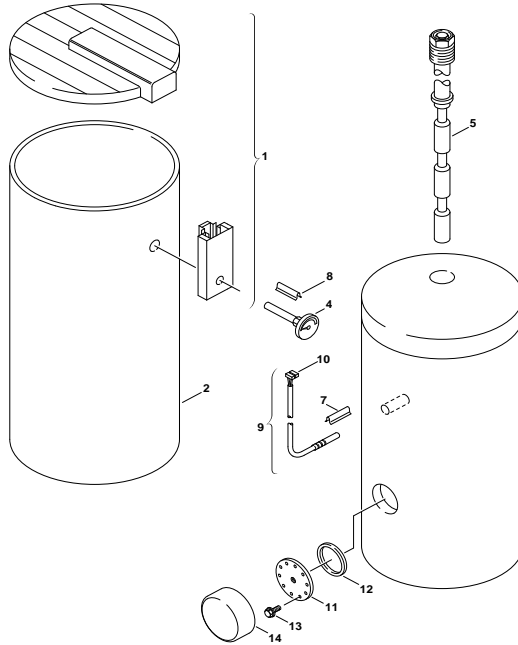

6720901211.AB/G

Pos	Bestell-Nr.	Bezeichnung	Description	Dénomination	Descrizione	Benaming	Descripción	PG
1	8 715 503 188 0	Haube hellgrau	Hood light grey	Carpot gris clair	Coperchio grigio chiaro	DEKSEL SK 160-4ZB (VOOR BOILER 7719001193)	Capota girar claro	42
2	8 715 401 256 0	Mantel weiß	Front shell white	Habillage blanc	Mantello bianco	Mantel wit	Carcasa blanco	49
4	8 717 208 050 0	Thermometer	Thermometer	Thermomètre	Termometro	Thermometer	Termómetro	31
5	8 709 918 506 0	Anode	Anode	Anode	Anodo	ANODE SO 160-160/1-200-200/1-SK 180-300-	Anodo	43
7	8 714 606 021 0	Klemmfeder	Clamp spring	Ressort	Fermo	KLEMVEER NTC SK120/140/160-4ZB	Muelle de tecla	25
8	8 714 606 024 0	Klemmfeder	Clamp spring	RESSORT POUR THERMOMETRE	Fermo	KLEMVEER V/THERMOMETER ST/SO	Muelle fijación	20
9	8 714 500 034 0	Sensor WW-NTC mit Aderendhülse 6m	Temperature sensor 6mm	SONDE DE TEMPERATURE 6mm	Sensore termometrico 6mm	Temperatuurvoeler 6mm	Sensor de temperatura 6mm	34
10	8 711 006 060 0	Stecker	Plug	Connecteur	Spina	STEKKER NTC-VOELER ST...1E(SK 300/ST 75)	Anection	16
11	8 715 503 170 0	Flansch mit Tauchrohr kpl.	Connecting flange	Bride de raccordement	Flangia	FLENS + DICHTING SK - 3ZB	Conjunto brida y junta SK500	40
12	8 710 103 096 0	Dichtungs-Set 100x109D - 115/138Dx3 (1x)	Set of seals 100x109D - 115/138Dx3 (1x)	Jeu de joints 100x109D - 115/138Dx3 (1x)	Set guarnizioni 100x109D - 115/138Dx3	DICHTING FLENS SK...2ZB-3ZB (VANAF 070)	conjunto de juntas 100x109D - 115/138Dx3	23
14	8 718 006 637 0	Abdeckung grau	Covering sheet grey	Couvercle gris	Coperchio grigio	Afdichting grijs	Chapa de protección girar	35
	8 710 402 029 0	Kappe	panel	Capot de protection	Tappo	beschermkapje	tapa	20

For:

Ersatzteilliste  
 Spare parts list  
 Liste des pièces de rechange  
 Lista parti di ricambio  
 Onderdelenlijst  
 Lista de repuestos

# SO200-1BS3500 - 7719001478

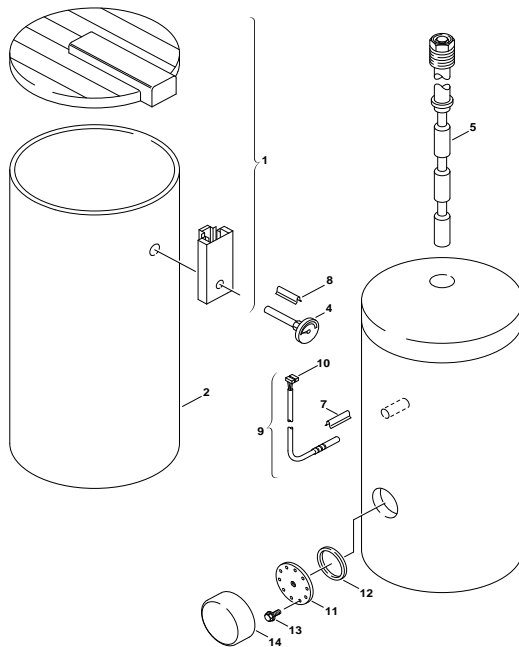

6720901211.AB/G

Pos	Bestell-Nr.	Bezeichnung	Description	Dénomination	Descrizione	Benaming	Descripción	PG
1	<b>8 715 503 188 0</b>	Haube hellgrau	Hood light grey	Carpot gris clair	Coperchio grigio chiaro	DEKSEL SK 160-4ZB (VOOR BOILER 771900193)	Capota girar claro	42
2	<b>8 715 401 256 0</b>	Mantel weiß	Front shell white	Habillage blanc	Mantello bianco	Mantel wit	Carcasa blanco	49
4	<b>8 717 208 050 0</b>	Thermometer	Thermometer	Thermomètre	Termometro	Thermometer	Termómetro	31
5	<b>8 709 918 506 0</b>	Anode	Anode	Anode	Anodo	ANODE SO 160-160/1-200-200/1-SK 180-300-	Anodo	43
7	<b>8 714 606 021 0</b>	Klemmfeder	Clamp spring	Ressort	Fermo	KLEMVEER NTC SK120/140/160-4ZB	Muelle de tecla	25
8	<b>8 714 606 024 0</b>	Klemmfeder	Clamp spring	RESSORT POUR THERMOMETRE	Fermo	KLEMVEER V/THERMOMETER ST/SO	Muelle fijación	20
9	<b>8 714 500 034 0</b>	Sensor WW-NTC mit Aderendhülse 6mm	Temperature sensor 6mm	SONDE DE TEMPERATURE 6mm	Sensore termometrico 6mm	Temperatuurvoeler 6mm	Sensor de temperatura 6mm	34
10	<b>8 711 006 060 0</b>	Stecker	Plug	Connecteur	Spina	STEKKER NTC-VOELER ST.-1E/SK 300/ST 75	Anection	16
11	<b>8 715 503 170 0</b>	Flansch mit Tauchrohr kpl.	Connecting flange	Bride de raccordement	Flangia	FLENS + DICHTING SK - 3ZB	Conjunto brida y junta SK500	40
12	<b>8 710 103 096 0</b>	Dichtungs-Set 100x109D - 115/138Dx3 (1x)	Set of seals 100x109D - 115/138Dx3 (1x)	Jeu de joints 100x109D - 115/138Dx3 (1x)	Set guarnizioni 100x109D - 115/138Dx3	DICHTING FLENS SK.-2ZB/3ZB (VANAF 070)	conjunto de juntas 100x109D - 115/138Dx3	23
14	<b>8 718 006 637 0</b>	Abdeckung grau	Covering sheet grey	Couvercle gris	Coperchio grigio	Afdichting grijs	Chapa de protección girar	35
	<b>8 710 402 029 0</b>	Kappe	panel	Capot de protection	Tappo	beschermkapje	tapa	20

For:

Ersatzteilliste  
Spare parts list  
Liste des pièces de rechange  
Lista parti di ricambio  
Onderdelenlijst  
Lista de repuestos

## SO200-1S3500 - 7719001450

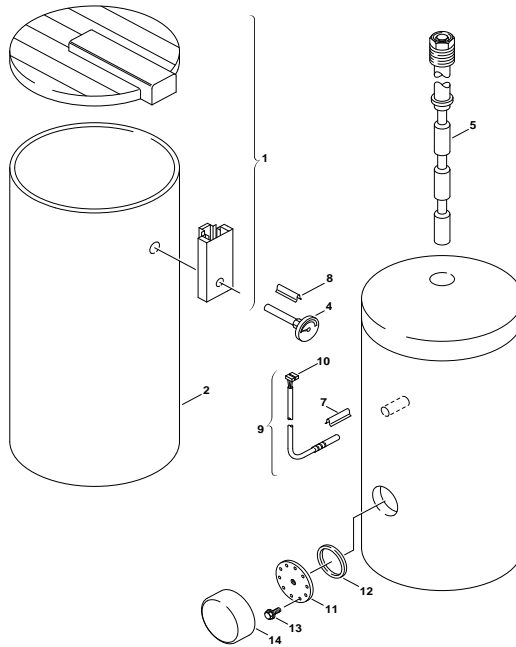

6720901211.AB/G

Pos	Bestell-Nr.	Bezeichnung	Description	Dénomination	Descrizione	Benaming	Descripción	PG	
1	<b>8 715 503 188 0</b>	Haube hellgrau	Hood light grey	Capot gris clair	Coperchio grigio chiaro	DEKSEL SK 160-42B (VOOR BOILER 771900193	Capota girar claro	42	
2	<b>8 715 401 256 0</b>	Mantel weiß	Front shell white	Habillage blanc	Mantello bianco		Carcasa blanco	49	
4	<b>8 717 208 050 0</b>	Thermometer	Thermometer	Thermomètre	Termometro		Termómetro	31	
5	<b>8 709 918 506 0</b>	Anode	Anode	Anode	Anodo	ANODE SO 160-160/1-200-200/1-SK 180-300-	Anodo	43	
7	<b>8 714 606 021 0</b>	Klemmfeder	Clamp spring	Ressort	Fermo	KLEMVEER NTC SK120/140/160-42B	Muelle de tecla	25	
8	<b>8 714 606 024 0</b>	Klemmfeder	Clamp spring	RESSORT POUR THERMOMETRE	Fermo	KLEMVEER V/THERMOMETER ST/50	Muelle fijación	20	
9	<b>8 714 500 034 0</b>	Sensor WW-NTC mit Aderendhülse 6mm	Temperature sensor 6mm	SONDE DE TEMPERATURE 6mm	Sensore termometrico 6mm		Sensor de temperatura 6mm	34	
10	<b>8 711 006 060 0</b>	Stecker	Plug	Connecteur	Spina	STEKKER NTC-VOELER ST.-1E/SK 300/ST 75	Aneccion	16	
	<b>7 709 500 048</b>	Rückschlagventil 3/4"	Non-return valve 3/4"	Soupape de non-retour 3/4"	Valvola di non ritorno 3/4"		Terugslagklep 3/4"	válvula de retención 3/4"	
	<b>7 709 500 052</b>	Überdruckventil 1/2*3/4" 10 bar	VÁLVULA SEG. 1/2*3/4" 10 bar	VÁLVULA SEG. 1/2*3/4" 10 bar	Valvola di sovrappressione 1/2*3/4"10 bar		Overdrukvelligheid 1/2*3/4" 10 bar	VÁLVULA SEG. 1/2*3/4" 10 bar	
	<b>8 710 402 029 0</b>	Kappe	panel	Capot de protection	Tappo		beschermpapje	tapa	20

For:

Ersatzteilliste  
Spare parts list  
Liste des pièces de rechange  
Lista parti di ricambio  
Onderdelenlijst  
Lista de repuestos

# SO200B - 7719000777

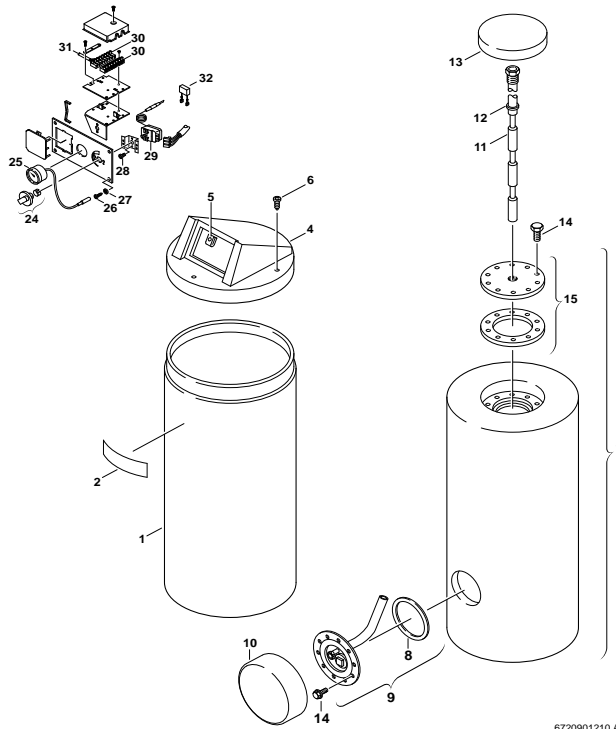

6720901210.AC/G

Pos	Bestell-Nr.	Bezeichnung	Description	Dénomination	Descrizione	Benaming	Descripción	PG
1	8 715 401 126 0	Mantel	Shell	Habillage	Mantello	Mantel	Carcasa	47
4	8 718 006 435 0	Deckel	Cover	Couvercle	Coperchio	Deksel	Tapa	39
5	8 713 309 026 0	Mutter (10x)	Nut	Ecrou (10x)	Dado (10x)	Moer (10x)	Tuerca (10x)	12
6	8 713 403 008 0	Schraube (10x)	Screw	Vis (10x)	Vite (10x)	Schroef (10x)	Tornillo (10x)	11
7	8 715 407 058 0	Behälter	Reservoir	Récipient	Sostegno	Reservoir	Déposito	67
8	8 710 103 096 0	Dichtungs-Set 100x109D - 115/138Dx3 (1x)	Set of seals 100x109D - 115/138Dx3 (1x)	Jeu de joints 100x109D - 115/138Dx3 (1x)	Set guarnizioni 100x109D - 115/138Dx3	DICHTING FLENS SK...ZZB-3ZB (VANAF 070)	conjunto de juntas 100x109D - 115/138Dx3	23
9	8 715 503 170 0	Flansch mit Tauchrohr kpl.	Connecting flange	Bride de raccordement	Flangia	FLENS + DICHTING SK - 3ZB	Conjunto brida y junta SK500	40
10	8 718 006 541 0	Abdeckung	Covering sheet	Couvercle	Coperchio	Afdichting	Chapa de protección	22
11	8 709 918 506 0	Anode	Anode	Anode	Anodo	ANODE SO 160-160/1-200-2001-SK 180-300-	Anodo	43
12	8 710 103 086 0	Dichtscheibe (10x)	Washer (10x)	Joint (10x)	Guarnizione (10x)	DICHTING ANODE VOOR SO 160	Junta (10x)	22
13	8 718 006 397 0	Isolierung	Insulation	Isolation	Isolamento	Isolatie	Aislamiento	23
14	2 911 060 342 0	Schraube M12x30 (10x)	Screw M12x30 (10x)	Vis M12x30 (10x)	Vite M12x30 (10x)	Schroef M12x30 (10x)	Tornillo M12x30 (10x)	16
24	8 712 000 034 0	Drehknopf	Rotary handle	Bouton de réglage	Manopola	Regelknop	Botón rotativo	12
25	8 737 208 991 0	Thermometer	Thermometer	Thermomètre	Termometro	THERMOMETER SO...SK...ZZ-3Z - Z(W)...F	Termómetro	37
26	8 713 403 008 0	Schraube (10x)	Screw	Vis (10x)	Vite (10x)	Schroef (10x)	Tornillo (10x)	11
27	2 916 030 006 0	Sicherungsscheibe (10x)	Retaining ring (10x)	Circlips (10x)	Rondella (10x)	BORGRING UIT TTB 771900055P	Arandela de seguridad (10x)	11
29	8 717 206 186 0	Temperaturregler	Flow thermostat	Thermostat	Thermostat	AQUASTAAT MWISSELKONTAKT SO 120-160-200	Regulador de temperatura	36
30	8 711 006 046 0	Klemmleiste 24V	Terminal strip 24V	Bornier 24V	Cablaggio 24V	Klemmenstrook 24V	Regleta de bornes 24V	08
31	8 714 401 396 0	Kabel	Cable	Faisceau	Cablaggio	Kabel	Cable	23
32	8 717 301 017 0	Entstörkondensator	ENTSTÖRKONDENSATOR	Condensateur	Condensatore	CONDENSATOR VOOR AQUASTAAT 8 737 206 974	Condensador filtro	14

For:

Ersatzteilliste  
 Spare parts list  
 Liste des pièces de rechange  
 Lista parti di ricambio  
 Onderdelenlijst  
 Lista de repuestos

## SP 750 SOLAR - 7739300114

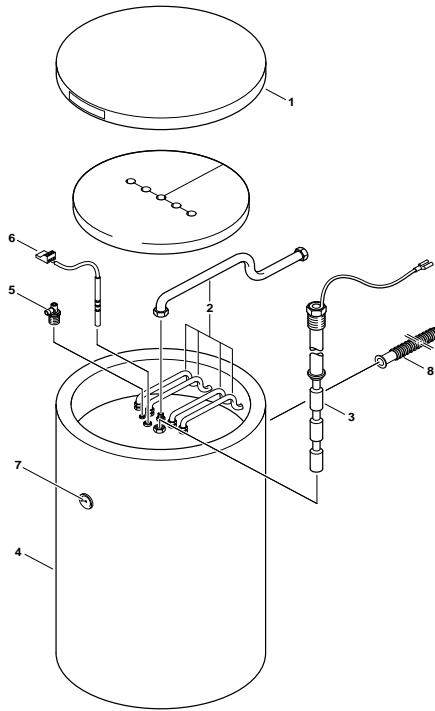

6720901041.AD/RS

Pos	Bestell-Nr.	Bezeichnung	Description	Dénomination	Descrizione	Benaming	Descripción	PG
1	8 718 006 842 0	Deckel silbergrau	Cover silver grey	Couvercle argent gris	Coperchio argentato grigio	Deksel zilver grijs	Tapa plata girar	32
2	7 739 300 178	ZL 103 Verbindungsrohr Wasser	ZL 103 connecting pipe water	ZL 103 Tube de raccordement eau	ZL 103 Tubo connes nichelcol xSP750solar	ZL-103 AANSLUITSET CIRCULATIELEIDING SP	ZL 103 tubería de conexión	
3	8 709 918 666 0	Anode 1"	Anode 1"	Anode 1"	Anodo 1"	ANODE (KETTING) ST120/160-1E /SK 130-3Z	Anodo 1"	43
4	7 739 300 395	Mantel weiss	FRONT SHELL WITHE	Habillage blanc	mantello bianco	Mantel wit	Mantello bianco	
4	7 739 300 396	Mantel silber	FRONT SHELL silver	Habillage argent	Carcasa plata	Mantel zilver	Mantello argento	
5	8 719 918 722 0	Entlüftungsventil	Vent valve	Dégazeur	Valvola di scarico	Ontluchtventiel	Válvula de purga de aire	13
6	8 714 500 034 0	Sensor WW-NTC mit Aderendhülse 6m	Temperature sensor 6mm	SONDE DE TEMPERATURE 6mm	Sensore termometrico 6mm	Temperatuurvoeler 6mm	Sensor de temperatura 6mm	34
7	8 717 208 059 0	Thermometer	Thermometer	Thermomètre	Termometro	THERMOMETER SK 300-3ZB	Termómetro	38
8	8 718 225 083 0	Rohr-KW-Rohr, 1670mm lg.	Pipe 1670mm	Tube 1670mm	Tubo 1670mm	Pijp 1670mm	Tubería de agua fría 1670mm	45
For:								







Ersatzteilliste  
 Spare parts list  
 Liste des pièces de rechange  
 Lista parti di ricambio  
 Onderdelenlijst  
 Lista de repuestos

## ST 65 E - 7719003009

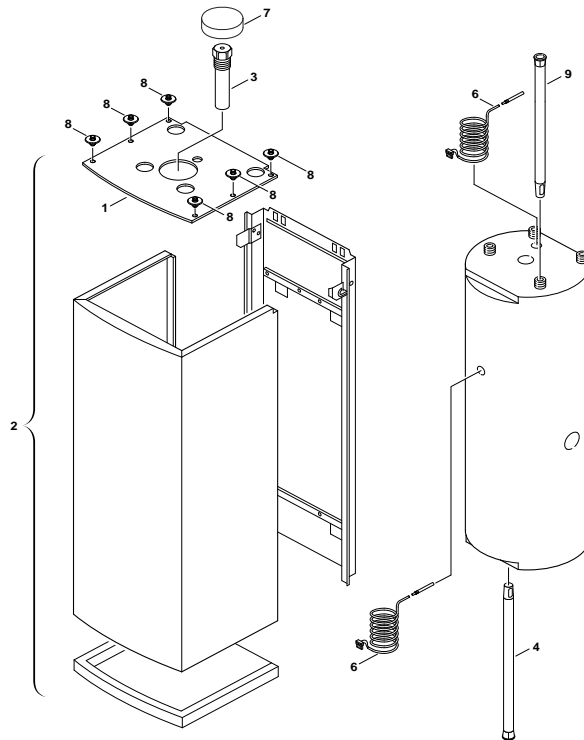

6720904841.aa.RS-Speicher STE65E, STE65E S0800

Pos	Bestell-Nr.	Bezeichnung	Description	Dénomination	Descrizione	Benaming	Descripción	PG
1	8 718 221 283 0	Deckel weiss	Cover white	Couvercle blanc	Coperchio bianco	Deksel wit	Tapa blanco	39
2	8 718 221 282 0	Ummantelung weiss	Coat	Jaquette	Rivestimento	Mantel	Carcasa	51
3	8 739 722 240 0	Kettenanode	Anode	ANODE MAGNESIUM SH290RW	Anodo	Anode	Anodo	47
4	8 710 735 457 0	Einlaufrohr Edelstahl 915lg.	Inlet tube stainless steel	Tube d'arrivée acier spécial	Tubo della presa acciaio raffinato	BUIS (INOX) INTERN BOILERS ST...2E	Pipa del producto acero afinado	39
6	8 714 500 034 0	Sensor WW-NTC mit Aderendhülse 6m	Temperature sensor 6mm	SONDE DE TEMPERATURE 6mm	Sensore termometrico 6mm	Temperatuurvoeler 6mm	Sensor de temperatura 6mm	34
7	8 710 402 029 0	Kappe	panel	Capot de protection	Tappo	beschermkapje	tapa	20
8	8 718 221 700 0	Niet (10x)	Rivet (10x)	Rivet (10x)	Rivetta (10x)	Klinknagel (10x)	Remache de encastre (10x)	12
9	8 718 225 023 0	Rohr-Tauchrohr , Lg.915	Pipe	Tuyauterie	Tubo di raccordo	Aansluitpijp	Tubo agua	32

For:





Ersatzteilliste  
 Spare parts list  
 Liste des pièces de rechange  
 Lista parti di ricambio  
 Onderdelenlijst  
 Lista de repuestos

ST 90-3 E - 7719001542

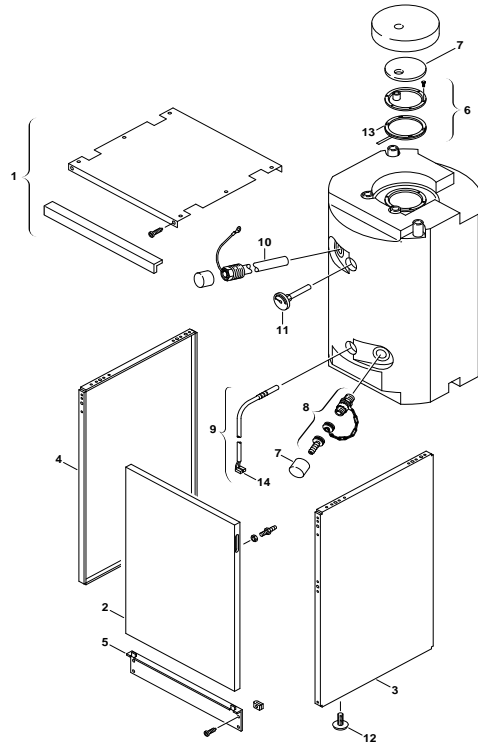

6720901192/G

Pos	Bestell-Nr.	Bezeichnung	Description	Dénomination	Descrizione	Benaming	Descripción	PG
1	8 729 011 029 0	Deckel	Cover	Couvercle	Coperchio	Deksel	Tapa	36
2	8 729 011 026 0	Vorderwand	Cover	Couvercle	Coperchio	Voordeksel	Tapa	35
3	8 729 011 027 0	Seitenwand rechts	Side panel right	Côté droit	Panello laterale a destra	Zijpaneel rechts	Pared lateral a la derecha	39
4	8 729 011 028 0	Seitenwand links	Side panel left	Côté gauche	Panello laterale sinistra	Zijpaneel links	Pared lateral a la izquierda	39
5	8 729 011 030 0	Blende	Shield	Cache	Mascherina	Paneel	Chapa cuadro	30
6	8 729 011 032 0	Flansch	Connecting flange	Bride de raccordement	Flangia	Aansluitflens	Brida de conexión	39
7	8 729 011 033 0	Isolierung	Insulation	Isolation	Isolamento	Isolatie	Aislamiento	23
8	8 738 505 974 0	Ventil	Globe valve	Robinet	Valvola	AFSLUITKRAAN	Válvula de globo	26
9	8 714 500 034 0	Sensor WW-NTC mit Aderendhülse 6m	Temperature sensor 6mm	SONDE DE TEMPERATURE 6mm	Sensore termometrico 6mm	Temperatuurvoeler 6mm	Sensor de temperatura 6mm	34
10	8 729 011 034 0	Anode	Anode	Anode	Anodo	Anode	Anodo	36
11	8 717 208 050 0	Thermometer	Thermometer	Thermomètre	Termometro	Thermometer	Termómetro	31
12	8 713 401 046 0	Stellfuß	Foot	Pied	Vite	Voet	Pie	13
13	8 710 103 513 0	Dichtung	Washer	Joint	Guarnizione	DICHTING ST 75	Junta	20
14	8 711 006 060 0	Stecker	Plug	Connecteur	Spina	STEKKER NTC-VOELER ST...1E/SK 300/ST 75	Anección	16

For:

Ersatzteilliste  
 Spare parts list  
 Liste des pièces de rechange  
 Lista parti di ricambio  
 Onderdelenlijst  
 Lista de repuestos

**ST 120-1 E - 7719002029**

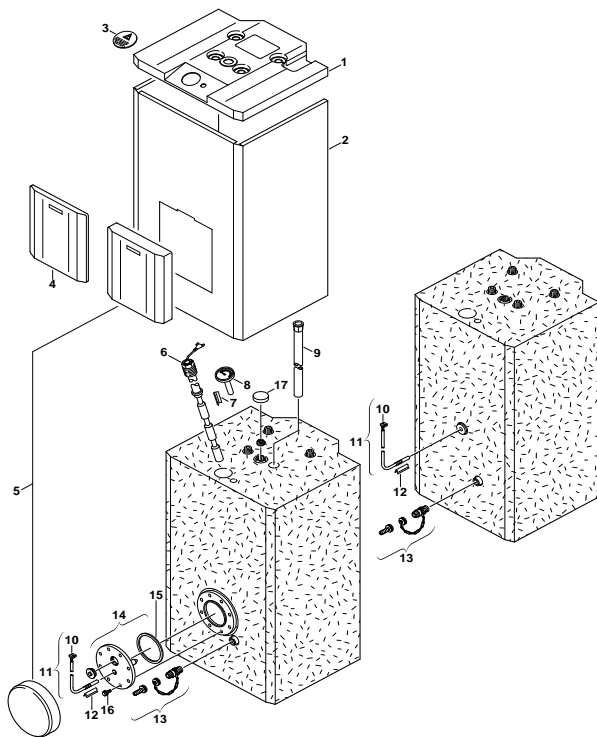

6720901198 AC/G

Pos	Bestell-Nr.	Bezeichnung	Description	Dénomination	Descrizione	Benaming	Descripción	PG
1	<b>8 715 503 369 0</b>	Haube hellgrau	Hood light grey	Carpot gris clair	Coperchio grigio chiaro	DEKSEL ST 120-1E/C1	Capota girar claro	41
2	<b>8 715 401 293 0</b>	Mantel weiß	Front shell white	Habillage blanc	Mantello bianco	Mantel wit	Carcasa blanco	53
3	<b>8 715 503 372 0</b>	Abdeckung hellgrau	Covering sheet light grey	Couvercle gris clair	Coperchio grigio chiaro	Afdichting lichtgrijs	Chapa de protección girar claro	30
4	<b>8 715 503 397 0</b>	Abdeckung hellgrau	Covering sheet light grey	Couvercle gris clair	Coperchio grigio chiaro	Afdichting lichtgrijs	Chapa de protección girar claro	41
6	<b>8 709 918 666 0</b>	Anode 1"	Anode 1"	Anode 1"	Anodo 1"	ANODE (KETTING) ST120/160-1E /SK 130-3Z	Anodo 1"	43
7	<b>8 714 606 024 0</b>	Klemmfeder	Clamp spring	RESSORT POUR THERMOMETRE	Fermo	KLEMVEER V/THERMOMETER ST/ISO	Muelle fijación	20
8	<b>8 717 208 050 0</b>	Thermometer	Thermometer	Thermomètre	Termometro	Thermometer	Termómetro	31
9	<b>8 710 735 442 0</b>	Einlaufrohr Edelstahl 850mm	Inlet tube stainless steel 850mm	Tube d'arrivée acier spécial 850mm	Tubo della presa acciaio raffinato 850mm	BUIS 850 MM INTERNE BOILERS (INOX)	Pipa del producto acero afinado 850mm	38
10	<b>8 711 006 060 0</b>	Stecker	Plug	Connecteur	Spina	STEKKER NTC-VOELER ST...1E/SK 300/ST 75	Anection	16
11	<b>8 714 500 034 0</b>	Sensor WW-NTC mit Aderendhülse 6m	Temperature sensor 6mm	SONDE DE TEMPERATURE 6mm	Sensore termometrico 6mm	Temperatuurvoeler 6mm	Sensor de temperatura 6mm	34
12	<b>8 714 606 021 0</b>	Klemmfeder	Clamp spring	Ressort	Fermo	KLEMVEER NTC SK120/140/160-4ZB	Muelle de tecla	25
13	<b>8 738 505 974 0</b>	Ventil	Globe valve	Robinet	Valvola	AFSLUITKRAAN	Válvula de globo	26
17	<b>8 715 503 239 0</b>	Isolierung	Insulation	Bouchon	Isolamento	ISOLATIE SK 300-1 SOLAR (7719001929)	Aislamiento	23

For:



Ersatzteilliste  
 Spare parts list  
 Liste des pièces de rechange  
 Lista parti di ricambio  
 Onderdelenlijst  
 Lista de repuestos

# ST 120-2 E - 7719002721

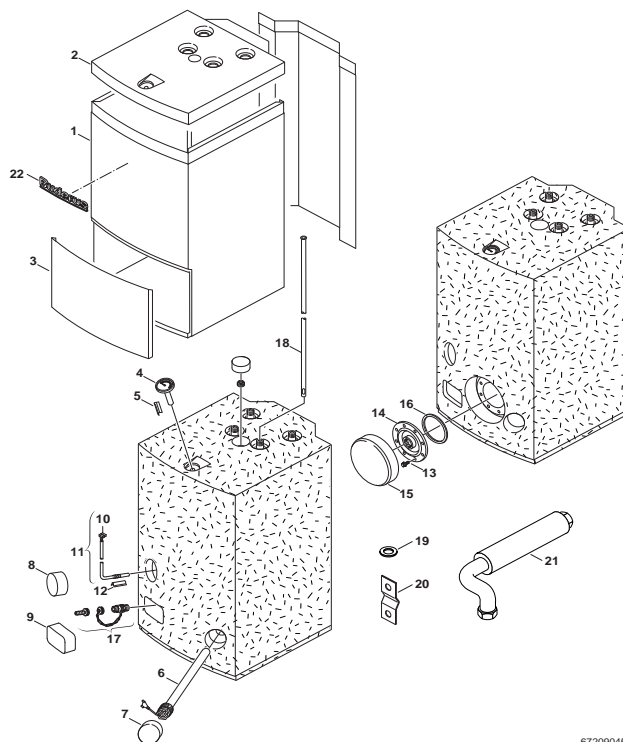

6720904582.aa.R

Pos	Bestell-Nr.	Bezeichnung	Description	Dénomination	Descrizione	Benaming	Descripción	PG
1	8 718 007 493 0	Mantel	Front shell	Habillage	Mantello	Mantel	Carcasa	49
2	8 715 503 570 0	Haube	Hood	Capot	Carpot	DEKSEL ST 120-2 E & EB	Capota	41
3	8 715 503 572 0	Abdeckung	Cover	Couvercle	Coperchio	Afdichting	Chapa de protección	34
4	8 717 208 111 0	Thermometer	Thermometer	Thermomètre	Termometro	THERMOMETER ST 120/160-2E-2EB	Termómetro	30
5	8 714 606 024 0	Klemmfeder	Clamp spring	RESSORT POUR THERMOMETRE	Fermo	KLEMVEER V/THERMOMETER ST/ISO	Muelle fijación	20
6	8 718 505 052 0	Anode isoliert, 480mm	Anode 480mm	Anode 480mm	Anodo 480mm	Anode 480mm	Anodo 480mm	41
7	8 710 402 029 0	Kappe	panel	Capot de protection	Tappo	beschermkapje	tapa	20
8	8 710 402 029 0	Kappe	panel	Capot de protection	Tappo	beschermkapje	tapa	20
9	8 710 402 031 0	Isolierung	Insulation	Isolation	Isolamento	Isolatie	Aislamiento	15
10	8 711 006 060 0	Stecker	Plug	Connecteur	Spina	STEKKER NTC-VOELER ST...1ESK 300/ST 75	Aneccion	16
11	8 714 500 034 0	Sensor WW-NTC mit Aderendhülse 6m	Temperature sensor 6mm	SONDE DE TEMPERATURE 6mm	Sensore termometrico 6mm	Temperatuurvoeler 6mm	Sensor de temperatura 6mm	34
17	8 738 505 974 0	Ventil	Globe valve	Robinet	Valvola	AFSLUITKRAAN	Válvula de globo	26
18	8 710 735 457 0	Einlaufrohr Edelstahl 915lg.	Inlet tube stainless steel	Tube d'arrivée acier spécial	Tubo della presa acciaio raffinato	BUIS (INOX) INTERN BOILERS ST...2E	Pipa del producto acero afinado	39
	8 711 301 131 0	Schelle	Clip	Support	Staffa	Klembeugel	Abrazadera	21

For:



Ersatzteilliste  
 Spare parts list  
 Liste des pièces de rechange  
 Lista parti di ricambio  
 Onderdelenlijst  
 Lista de repuestos

## ST 120-2 E - 7719003064

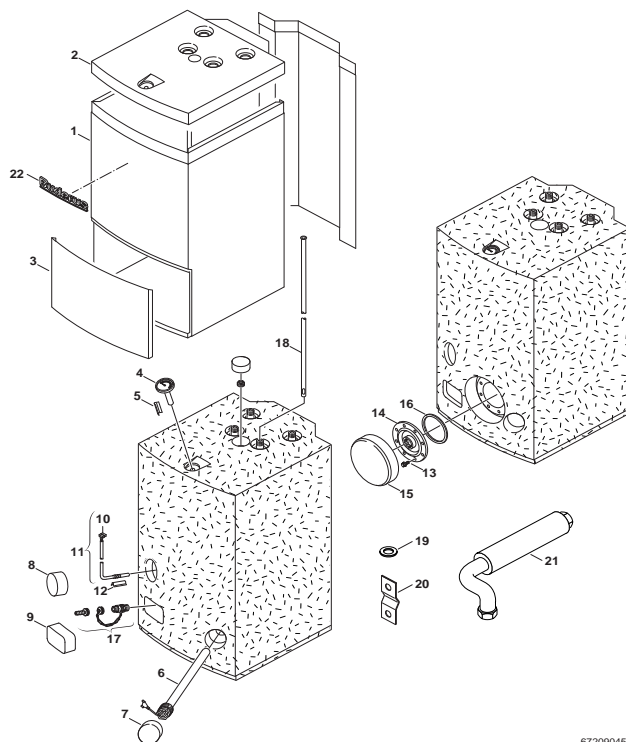

6720904582.aa.R

Pos	Bestell-Nr.	Bezeichnung	Description	Dénomination	Descrizione	Benaming	Descripción	PG
1	8 718 007 493 0	Mantel	Front shell	Habillage	Mantello	Mantel	Carcasa	49
2	8 715 503 570 0	Haube	Hood	Capot	Carpot	DEKSEL ST 120-2 E & EB	Capota	41
3	8 715 503 572 0	Abdeckung	Cover	Couvercle	Coperchio	Afdichting	Chapa de protección	34
4	8 717 208 111 0	Thermometer	Thermometer	Thermomètre	Termometro	THERMOMETER ST 120/160-2E-2EB	Termómetro	30
5	8 714 606 024 0	Klemmfeder	Clamp spring	RESSORT POUR THERMOMETRE	Fermo	KLEMVEER V/THERMOMETER ST/ISO	Muelle fijación	20
6	8 718 505 052 0	Anode isoliert, 480mm	Anode 480mm	Anode 480mm	Anodo 480mm	Anode 480mm	Anodo 480mm	41
7	8 710 402 029 0	Kappe	panel	Capot de protection	Tappo	beschermkapje	tapa	20
8	8 710 402 029 0	Kappe	panel	Capot de protection	Tappo	beschermkapje	tapa	20
9	8 710 402 031 0	Isolierung	Insulation	Isolation	Isolamento	Isolatie	Aislamiento	15
10	8 711 006 060 0	Stecker	Plug	Connecteur	Spina	STEKKER NTC-VOELER ST...1E/SK 300/ST 75	Aneccion	16
11	8 714 500 034 0	Sensor WW-NTC mit Aderendhülse 6m	Temperature sensor 6mm	SONDE DE TEMPERATURE 6mm	Sensore termometrico 6mm	Temperatuurvoeler 6mm	Sensor de temperatura 6mm	34
17	8 738 505 974 0	Ventil	Globe valve	Robinet	Valvola	AFSLUITKRAAN	Válvula de globo	26
18	8 710 735 457 0	Einlaufrohr Edelstahl 915lg.	Inlet tube stainless steel	Tube d'arrivée acier spécial	Tubo della presa acciaio raffinato	BUIS (INOX) INTERN BOILERS ST...2E	Pipa del producto acero afinado	39
	8 711 301 131 0	Schelle	Clip	Support	Staffa	Klembeugel	Abrazadera	21

For:

Ersatzteilliste  
Spare parts list  
Liste des pièces de rechange  
Lista parti di ricambio  
Onderdelenlijst  
Lista de repuestos

# ST 160-1 E - 7719002030

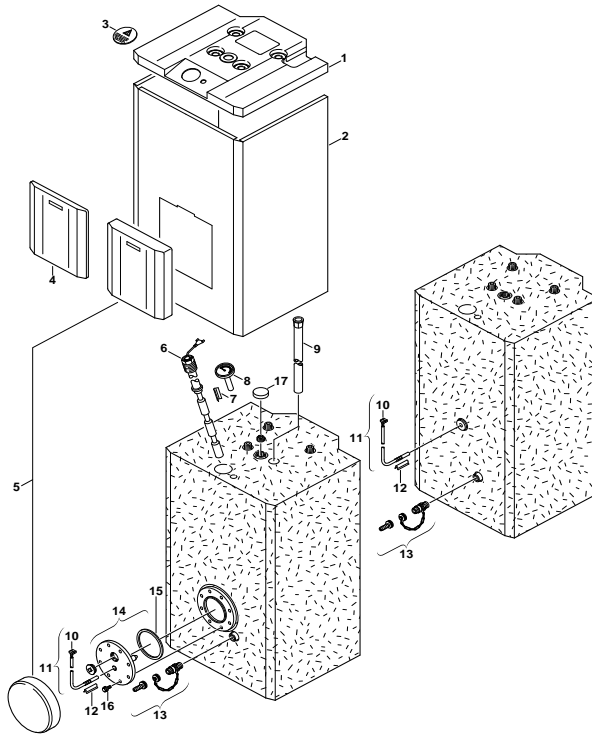

6720901198 AC/G

Pos	Bestell-Nr.	Bezeichnung	Description	Dénomination	Descrizione	Benaming	Descripción	PG
1	8 715 503 370 0	Haube hellgrau	Hood light grey	Carpot gris clair	Coperchio grigio chiaro	Deksel lichtgrijs	Capota girar claro	42
2	8 715 401 296 0	Mantel weiß	Front shell white	Habillage blanc	Mantello bianco	Mantel wit	Carcasa blanco	54
3	8 715 503 372 0	Abdeckung hellgrau	Covering sheet light grey	Couvercle gris clair	Coperchio grigio chiaro	Afdichting lichtgrijs	Chapa de protección girar claro	30
4	8 715 503 397 0	Abdeckung hellgrau	Covering sheet light grey	Couvercle gris clair	Coperchio grigio chiaro	Afdichting lichtgrijs	Chapa de protección girar claro	41
6	8 709 918 666 0	Anode 1"	Anode 1"	Anode 1"	Anodo 1"	ANODE (KETTING) ST120/160-1E /SK 130-3Z	Anodo 1"	43
7	8 714 606 024 0	Klemmfeder	Clamp spring	RESSORT POUR THERMOMETRE	Fermo	KLEMVEER V/THERMOMETRE ST/SO	Muelle fijación	20
8	8 717 208 050 0	Thermometer	Thermometer	Thermomètre	Termometro	Thermometer	Termómetro	31
9	8 710 735 442 0	Einlaufrohr Edelstahl 850mm	Inlet tube stainless steel 850mm	Tube d'arrivée acier spécial 850mm	Tubo della presa acciaio raffinato 850mm	BUIS 850 MM INTERNE BOILERS (INOX)	Pipa del producto acero afinado 850mm	38
10	8 711 006 060 0	Stecker	Plug	Connecteur	Spina	STEKKER NTC-VOELER ST.-1E/SK 300/ST 75	Anection	16
11	8 714 500 034 0	Sensor WW-NTC mit Aderendhülse 6m	Temperature sensor 6mm	SONDE DE TEMPERATURE 6mm	Sensore termometrico 6mm	Temperatuurvoeler 6mm	Sensor de temperatura 6mm	34
12	8 714 606 021 0	Klemmfeder	Clamp spring	Ressort	Fermo	KLEMVEER NTC SK120/140/160-4ZB	Muelle de tecla	25
13	8 738 505 974 0	Ventil	Globe valve	Robinet	Valvola	AFLSLUITKRAAN	Válvula de globo	26
17	8 715 503 239 0	Isolierung	Insulation	Bouchon	Isolamento	ISOLATIE SK 300-1 SOLAR (7719001929)	Aislamiento	23

For:

Ersatzteilliste  
Spare parts list  
Liste des pièces de rechange  
Lista parti di ricambio  
Onderdelenlijst  
Lista de repuestos

# ST 160-1 EO/C1 - 7719001396

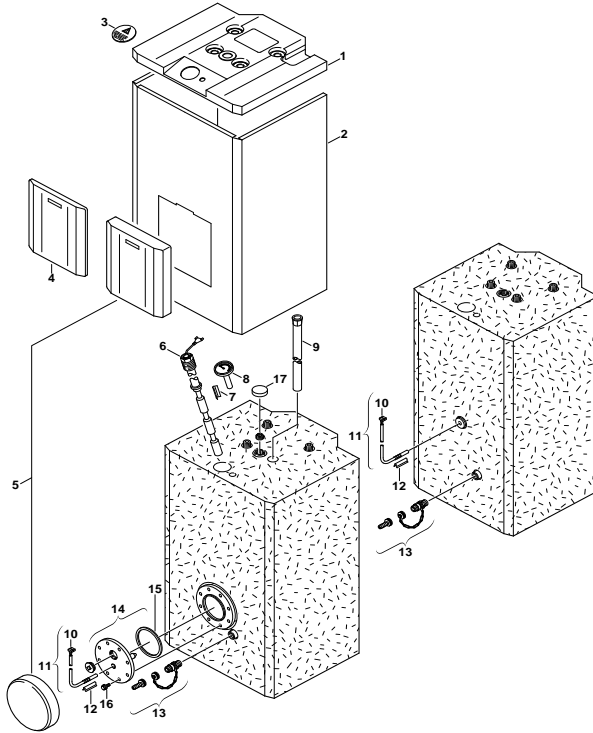

6720901198 AC/G

Pos	Bestell-Nr.	Bezeichnung	Description	Dénomination	Descrizione	Benaming	Descripción	PG
1	8 715 503 370 0	Haube hellgrau	Hood light grey	Capot gris clair	Coperchio grigio chiaro	Deksel lichtgrijs	Capota girar claro	42
3	8 715 503 372 0	Abdeckung hellgrau	Covering sheet light grey	Couvercle gris clair	Coperchio grigio chiaro	Afdichting lichtgrijs	Chapa de protección girar claro	30
6	8 709 918 666 0	Anode 1"	Anode 1"	Anode 1"	Anodo 1"	ANODE (KETTING) ST120/160-1E /SK 130-3Z	Anodo 1"	43
7	8 714 606 024 0	Klemmfeder	Clamp spring	RESSORT POUR THERMOMETRE	Fermo	KLEMVEER V/THERMOMETRE ST/ISO	Muelle fijación	20
8	8 717 208 050 0	Thermometer	Thermometer	Thermomètre	Termometro	Thermometer	Termómetro	31
9	8 710 735 442 0	Einlaufrohr Edelstahl 850mm	Inlet tube stainless steel 850mm	Tube d'arrivée acier spécial 850mm	Tubo della presa acciaio raffinato 850mm	BUIS 850 MM INTERNE BOILERS (INOX)	Pipa del producto acero afinado 850mm	38
10	8 711 006 060 0	Stecker	Plug	Connecteur	Spina	STEKKER NTC-VOELER ST.-1E/SK 300/ST 75	Anection	16
11	8 714 500 034 0	Sensor WW-NTC mit Aderendhülse 6m	Temperature sensor 6mm	SONDE DE TEMPERATURE 6mm	Sensore termometrico 6mm	Temperatuurvoeler 6mm	Sensor de temperatura 6mm	34
12	8 714 606 021 0	Klemmfeder	Clamp spring	Ressort	Fermo	KLEMVEER NTC SK120/140/160-4ZB	Muelle de tecla	25
13	8 738 505 974 0	Ventil	Globe valve	Robinet	Valvola	AFSLUITKRAAN	Válvula de globo	26
17	8 715 503 239 0	Isolierung	Insulation	Bouchon	Isolamento	ISOLATIE SK 300-1 SOLAR (7719001929)	Aislamiento	23

For:

Ersatzteilliste  
 Spare parts list  
 Liste des pièces de rechange  
 Lista parti di ricambio  
 Onderdelenlijst  
 Lista de repuestos

# ST 160-2 E - 7719002722

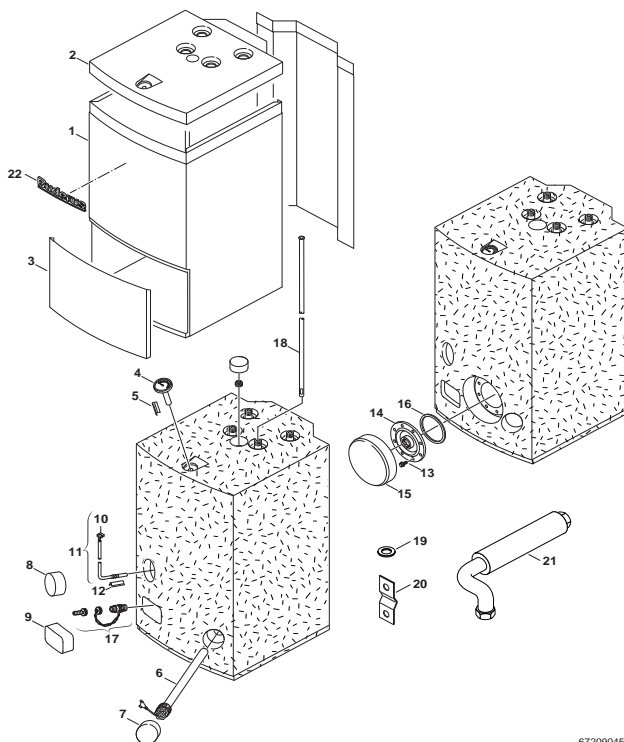

6720904582.aa.R

Pos	Bestell-Nr.	Bezeichnung	Description	Dénomination	Descrizione	Benaming	Descripción	PG
1	8 718 007 494 0	Mantel	Front shell	Habillage	Mantello	MANTEL VOOR ST 160-2EB "STORACELL"	Carcasa	50
2	8 715 503 571 0	Haube	Hood	Capot	Carpot	DEKSEL ST 160-2E	Capota	41
3	8 715 503 573 0	Abdeckung	Cover	Couvercle	Coperchio	Afdichting	Chapa de protección	35
4	8 717 208 111 0	Thermometer	Thermometer	Thermomètre	Termometro	THERMOMETER ST 120/160-2E-2EB	Termómetro	30
5	8 714 606 024 0	Klemmfeder	Clamp spring	RESSORT POUR THERMOMETRE	Fermo	KLEMVEER V/THERMOMETER ST/SO	Muelle fijación	20
6	8 718 505 052 0	Anode isoliert, 480mm	Anode 480mm	Anode 480mm	Anodo 480mm	Anode 480mm	Anodo 480mm	41
7	8 710 402 029 0	Kappe	panel	Capot de protection	Tappo	beschermkapje	tapa	20
8	8 710 402 029 0	Kappe	panel	Capot de protection	Tappo	beschermkapje	tapa	20
9	8 710 402 031 0	Isolierung	Insulation	Isolation	Isolamento	Isolatie	Aislamiento	15
10	8 711 006 060 0	Stecker	Plug	Connecteur	Spina	STEKKER NTC-VOELER ST...1E/SK 300/ST 75	Anection	16
11	8 714 500 034 0	Sensor WW-NTC mit Aderendhülse 6m	Temperature sensor 6mm	SONDE DE TEMPERATURE 6mm	Sensore termometrico 6mm	Temperatuurvoeler 6mm	Sensor de temperatura 6mm	34
17	8 738 505 974 0	Ventil	Globe valve	Robinet	Valvola	AFSLUITKRAAN	Válvula de globo	26
18	8 710 735 457 0	Einlaufrohr Edelstahl 915lg.	Inlet tube stainless steel	Tube d'arrivée acier spécial	Tubo della presa acciaio raffinato	BUIS (INOX) INTERN BOILERS ST...2E	Pipa del producto acero afinado	39
	8 711 301 131 0	Schelle	Clip	Support	Staffa	Klembeugel	Abrazadera	21

For:



**Ersatzteilliste**  
**Spare parts list**  
 Liste des pièces de rechange  
 Lista parti di ricambio  
 Onderdelenlijst  
 Lista de repuestos

# ST50-2 - 7719000638

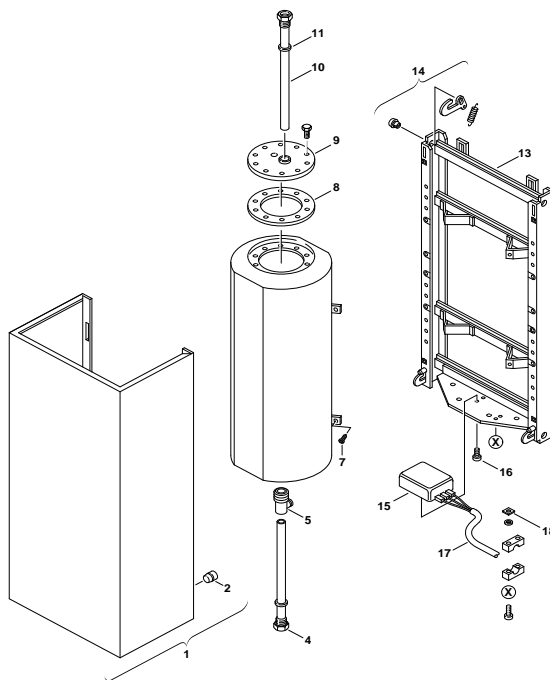

6720901201/G

Pos	Bestell-Nr.	Bezeichnung	Description	Dénomination	Descrizione	Benaming	Descripción	PG
1	8 715 401 093 0	Mantel	Front shell	Habillage	Mantello	Mantel	Carcasa	42
2	8 710 305 079 0	Buchse (10x)	Sleeve (10x)	Douille (10x)	Boccola (10x)	Huls (10x)	Manguito (10x)	11
4	8 710 702 047 0	Tauchhülse	Sensor pocket	Douille	Boccola	Dompelhuls	Casquillo de la caldera	28
5	8 713 305 498 0	Rohrstutzen	Pipe fitting	Douille	Tube	Pijp stuts	Tubuladura	35
7	2 910 619 454 0	Schraube (10x)	Screw M6x13 phillips steel cross	VIS (10x)	Vite (10x)	Schroef (10x)	Tornillo (10x)	16
8	8 710 103 091 0	Dichtung	Washer	Joint	Guarnizione	Packingring	Junta	19
9	8 715 503 111 0	Flansch	Connecting flange	Bride de raccordement	Flangia	Aansluitflens	Brida de conexión	39
10	8 709 918 505 0	Anode	Anode	Anode	Anodo	ANODE SO 120-SK 130/2Z-ST 120	Anodo	39
11	8 710 103 086 0	Dichtscheibe (10x)	Washer (10x)	Joint (10x)	Guarnizione (10x)	DICHTING ANODE VOOR SO 160	Junta (10x)	22
14	8 712 000 051 0	Drehknopf	Rotary handle	Bouton de réglage	Manopola	Regelknop	Botón rotativo	09
15	8 717 206 120 0	Temperaturregler	Flow thermostat	Thermostat	Thermostat	Boilerthermostaat	Regulador de temperatura	42
18	2 915 121 004 0	Mutter (10x)	Nut (10x)	Ecrou (10x)	Dado (10x)	Moer (10x)	Tuerca (10x)	11

For:

Ersatzteilliste  
 Spare parts list  
 Liste des pièces de rechange  
 Lista parti di ricambio  
 Onderdelenlijst  
 Lista de repuestos

# ST50-3 - 7719000863

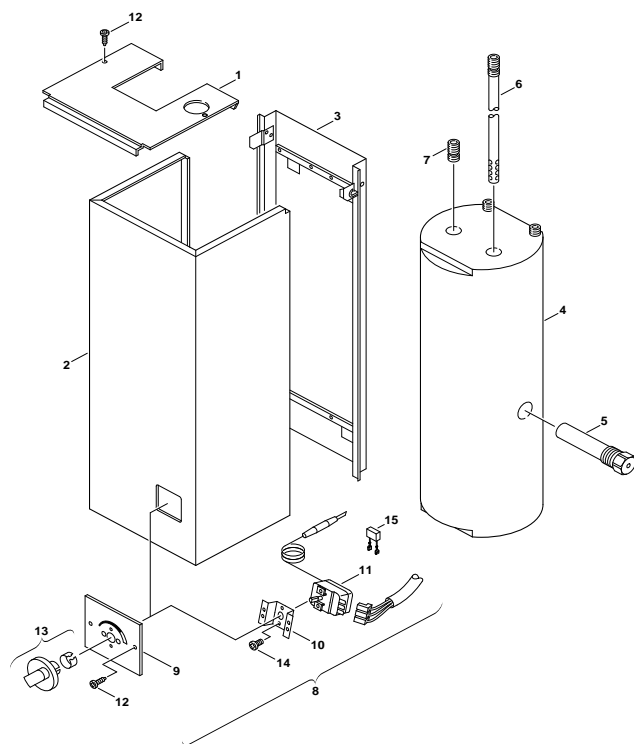

6720901202.AB/G

Pos	Bestell-Nr.	Bezeichnung	Description	Dénomination	Descrizione	Benaming	Descripción	PG
1	8 718 005 446 0	Deckel	Cover	Couvercle	Coperchio	Deksel	Tapa	42
2	8 718 005 378 0	Mantel	Front shell	Habillage	Mantello	Mantel	Carcasa	52
3	8 715 402 183 0	Rückwand	Backpanel	Dosseret	Schienale	Achterwand	Respaldo	13
5	8 709 918 638 0	Anode 1"	Anode 1"	Anode 1"	Anodo 1"	ANODE SK 120/140/160-4ZB	Anodo 1"	37
6	8 710 735 188 0	Einlaufrohr Edelstahl 761mm	Inlet tube stainless steel 761mm	Tube d'arrivée acier spécial 761mm	Tubo della presa acciaio raffinato 761mm	BUIS 760 MM INTERN BOILERS ST (INOX)	Pipa del producto acero afinado 761mm	38
7	8 710 735 187 0	Auslaufrohr Edelstahl 120mm	Outlet tube stainless steel 120mm	Tube de sortie acier spécial 120mm	Tubo di uscita in acciaio 120mm	Stalen uitloopbuisje 120mm	Tubo de salida del producto acero afinar	36
8	8 717 207 280 0	Schalteinsatz	Insert of commutation	Insert de commutation	Quadro comandi	Schakelinzetstuk	Cuadro de mandos	46
9	8 715 506 203 0	Blende	Shield	Cache	Mascherina	Paneel	Chapa cuadro	25
10	8 711 302 082 0	Bügel	Wire form spring	Epingle	Fermo a molla	Borgveer	Clip de fijación	12
11	8 717 206 186 0	Temperaturregler	Flow thermostat	Thermostat	Thermostat	AQUASTAAT MWISSELKONTAKT SO 120-160-200	Regulador de temperatura	36
12	8 713 403 008 0	Schraube (10x)	Screw	Vis (10x)	Vite (10x)	Schroef (10x)	Tornillo (10x)	11
13	8 712 000 034 0	Drehknopf	Rotary handle	Bouton de réglage	Manopola	Regelknop	Botón rotativo	12
15	8 717 301 017 0	Entstörkondensator	ENTSTÖRKONDENSATOR	Condensateur	Condensatore	CONDENSATOR VOOR AQUASTAAT 8 737 206 974	Condensador filtro	14
	8 718 005 381 0	Abdeckung	Covering sheet	Couvercle	Coperchio	Afdichting	Chapa de protección	41
For:								

Ersatzteilliste  
 Spare parts list  
 Liste des pièces de rechange  
 Lista parti di ricambio  
 Onderdelenlijst  
 Lista de repuestos

# ST50-4 - 7719001079

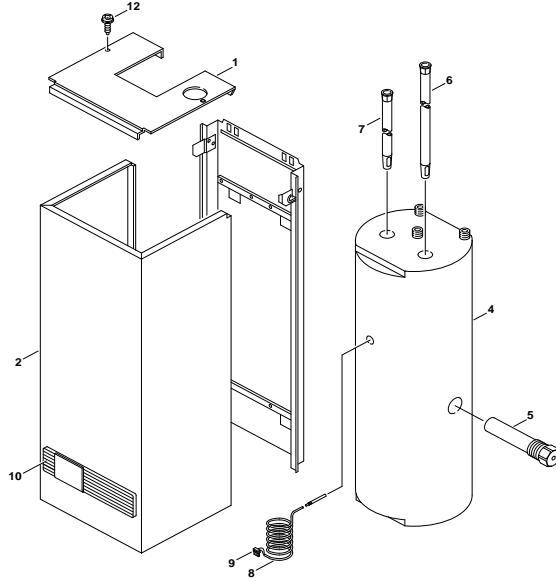

6720901203/G

Pos	Bestell-Nr.	Bezeichnung	Description	Dénomination	Descrizione	Benaming	Descripción	PG
1	8 718 005 446 0	Deckel	Cover	Couvercle	Coperchio	Deksel	Tapa	42
2	8 718 005 491 0	Mantel	Front shell	Habillage	Mantello	Mantel	Carcasa	53
5	8 709 918 638 0	Anode 1"	Anode 1"	Anode 1"	Anodo 1"	ANODE SK 120/140/160-4ZB	Anodo 1"	37
6	8 710 735 188 0	Einlaufrohr Edelstahl 761mm	Inlet tube stainless steel 761mm	Tube d'arrivée acier spécial 761mm	Tubo della presa acciaio raffinato 761mm	BUIS 760 MM INTERN BOILERS ST (INOX)	Pipa del producto acero afinado 761mm	38
7	8 710 735 187 0	Auslaufrohr Edelstahl 120mm	Outlet tube stainless steel 120mm	Tube de sortie acier spécial 120mm	Tubo di uscita in acciaio 120mm	Stalen uitloopbuisje 120mm	Tubo de salida del producto acero afinar	36
8	8 714 500 034 0	Sensor WW-NTC mit Aderendhülse 6m	Temperature sensor 6mm	SONDE DE TEMPERATURE 6mm	Sensore termometrico 6mm	Temperatuurvoeler 6mm	Sensor de temperatura 6mm	34
9	8 711 006 060 0	Stecker	Plug	Connecteur	Spina	STEKKER NTC-VOELER ST.-1E/SK 300/ST 75	Anection	16
10	8 715 506 257 0	Klappe	Cover	Couvercle	Sportello	Deksel	Tapa	36

For:



**Ersatzteilliste**  
**Spare parts list**  
**Liste des pièces de rechange**  
**Lista parti di ricambio**  
**Onderdelenlijst**  
**Lista de repuestos**

**ST50ES - 7719001977**

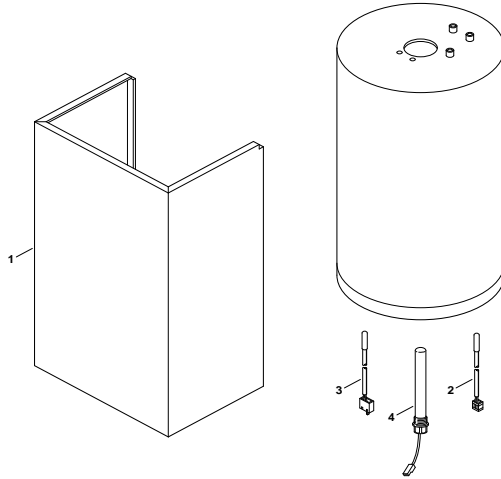

6720901196/G

Pos	Bestell-Nr.	Bezeichnung	Description	Dénomination	Descrizione	Benaming	Descripción	PG
1	8 715 402 389 0	Vorderwand	Front_Panel	Couvercle	Coperchio	Voordeksel	Tapa	52
2	8 714 500 088 0	Temperaturfühler NTC1	Temperature sensor NTC1	Sonde de temperature CTN1	Sensore termometrico NTC1	Temperatuurvoeler NTC1	Sensor de temperatura NTC1	34
3	8 714 500 090 0	Temperaturfühler NTC2	Temperature sensor NTC2	Sonde de temperature CTN2	Sensore termometrico NTC2	Temperatuurvoeler NTC2	Sensor de temperatura NTC2	39
4	8 718 505 037 0	Anode	Anode	Anode	Anodo	Anode	Anodo	34

For:



**Ersatzteilliste**  
**Spare parts list**  
**Liste des pièces de rechange**  
**Lista parti di ricambio**  
**Onderdelenlijst**  
**Lista de repuestos**

## ST75 - 7719002870

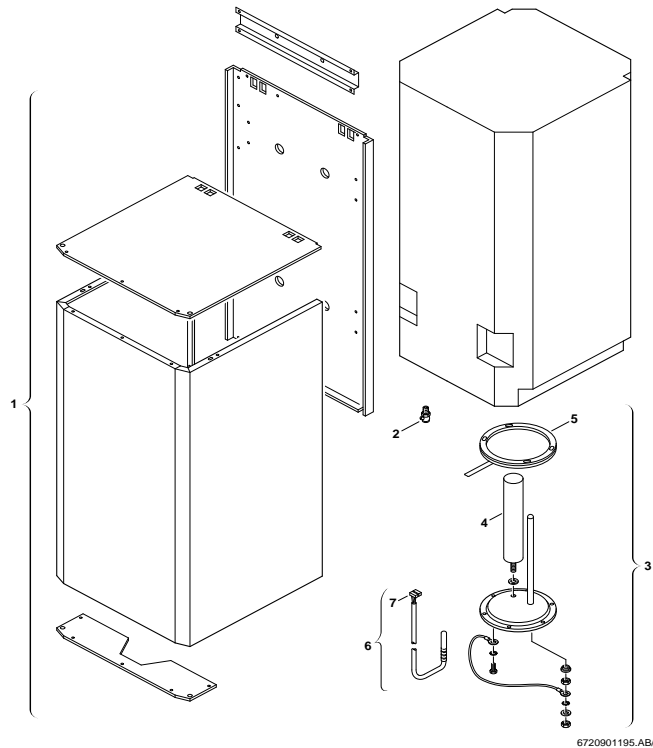

Pos	Bestell-Nr.	Bezeichnung	Description	Dénomination	Descrizione	Benaming	Descripción	PG
1	8 715 402 336 0	Vorderwand	Cover	Couvercle	Coperchio	MANTEL ST 75	Tapa	47
2	8 718 505 035 0	Entlüftungsventil	Vent valve	Dégazeur	Valvola di scarico	ONTLUCHTER VOOR ST 75	Válvula de purga de aire	13
3	8 715 503 279 0	Flansch	Connecting flange	Bride de raccordement	Flangia	FLENS ST 75 INCL. DICHTING + ANODE	Brida de conexión	41
4	8 719 928 002 0	Anode	Anode	Anode	Anodo	ANODE ST 75	Anodo	34
5	8 710 103 513 0	Dichtung	Washer	Joint	Guarnizione	DICHTING ST 75	Junta	20
6	8 714 500 034 0	Sensor WW-NTC mit Aderendhülse 6m	Temperature sensor 6mm	SONDE DE TEMPERATURE 6mm	Sensore termometrico 6mm	Temperatuurvoeler 6mm	Sensor de temperatura 6mm	34
7	8 711 006 060 0	Stecker	Plug	Connecteur	Spina	STEKKER NTC-VOELER ST...1E/SK 300/ST 75	Aneccion	16

For:

Ersatzteilliste  
Spare parts list  
Liste des pièces de rechange  
Lista parti di ricambio  
Onderdelenlijst  
Lista de repuestos

# ST75ES - 7719001978

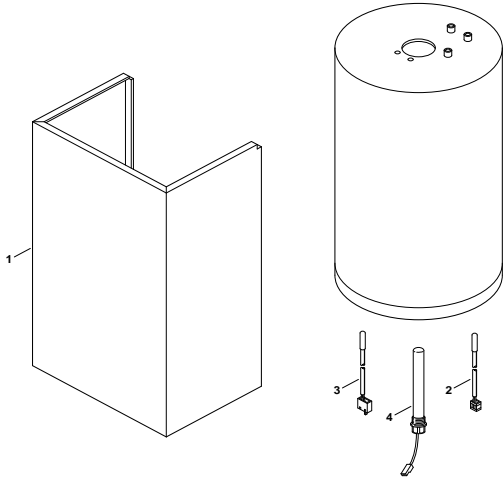

6720901196/G

Pos	Bestell-Nr.	Bezeichnung	Description	Dénomination	Descrizione	Benaming	Descripción	PG
1	<b>8 715 402 389 0</b>	Vorderwand	Front_Panel	Couvercle	Coperchio	Voordeksel	Tapa	52
2	<b>8 714 500 088 0</b>	Temperaturfühler NTC1	Temperature sensor NTC1	Sonde de temperature CTN1	Sensore termometrico NTC1	Temperatuurvoeler NTC1	Sensor de temperatura NTC1	34
3	<b>8 714 500 090 0</b>	Temperaturfühler NTC2	Temperature sensor NTC2	Sonde de temperature CTN2	Sensore termometrico NTC2	Temperatuurvoeler NTC2	Sensor de temperatura NTC2	39
4	<b>8 718 505 037 0</b>	Anode	Anode	Anode	Anodo	Anode	Anodo	34

For:

Ersatzteilliste  
Spare parts list  
Liste des pièces de rechange  
Lista parti di ricambio  
Onderdelenlijst  
Lista de repuestos

# ST75S0200 - 7719002092

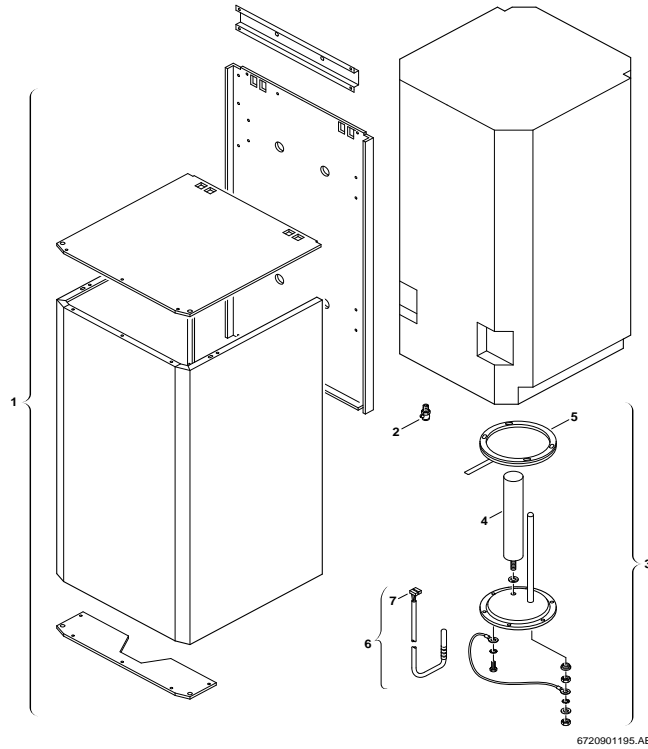

6720901195.AB/G

Pos	Bestell-Nr.	Bezeichnung	Description	Dénomination	Descrizione	Benaming	Descripción	PG
1	8 715 402 336 0	Vorderwand	Cover	Couvercle	Coperchio	MANTEL ST 75	Tapa	47
2	8 718 505 035 0	Entlüftungsventil	Vent valve	Dégazeur	Valvola di scarico	ONTLUCHTER VOOR ST 75	Válvula de purga de aire	13
3	8 715 503 279 0	Flansch	Connecting flange	Bride de raccordement	Flangia	FLENS ST 75 INCL. DICHTING + ANODE	Brida de conexión	41
4	8 719 928 002 0	Anode	Anode	Anode	Anodo	ANODE ST 75	Anodo	34
5	8 710 103 513 0	Dichtung	Washer	Joint	Guarnizione	DICHTING ST 75	Junta	20
6	8 714 500 034 0	Sensor WW-NTC mit Aderendhülse 6m	Temperature sensor 6mm	SONDE DE TEMPERATURE 6mm	Sensore termometrico 6mm	Temperatuurvoeler 6mm	Sensor de temperatura 6mm	34
7	8 711 006 060 0	Stecker	Plug	Connecteur	Spina	STEKKER NTC-VOELER ST.-1E/SK 300/ST 75	Aneccion	16

For:



**Ersatzteilliste**  
**Spare parts list**  
**Liste des pièces de rechange**  
**Lista parti di ricambio**  
**Onderdelenlijst**  
**Lista de repuestos**

# ST80-3 - 7719000864

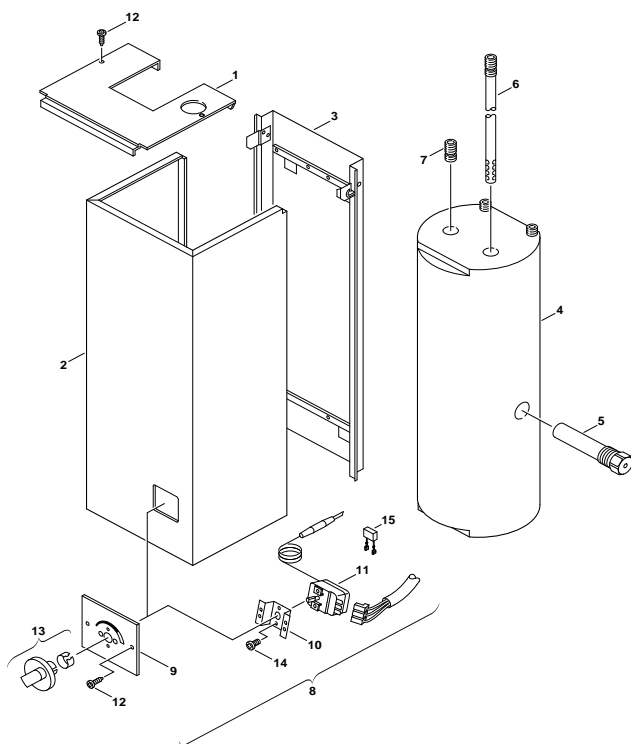

6720901202.AB/G

Pos	Bestell-Nr.	Bezeichnung	Description	Dénomination	Descrizione	Benaming	Descripción	PG
1	8 718 005 446 0	Deckel	Cover	Couvercle	Coperchio	Deksel	Tapa	42
2	8 718 005 376 0	Mantel	Front shell	Habillage	Mantello	Mantel	Carcasa	55
3	8 715 402 182 0	Rückwand	Backpanel	Dosseret	Schienale	Achterwand	Respaldo	13
4	8 715 407 059 0	Behälter	Reservoir	Récipient	Sostegno	Reservoir	Déposito	65
5	8 709 918 638 0	Anode 1"	Anode 1"	Anode 1"	Anodo 1"	ANODE SK 120/140/160-4ZB	Anodo 1"	37
6	8 710 735 189 0	Einlaufrohr Edelstahl 1080mm	Inlet tube stainless steel 1080mm	Tube d'arrivée acier spécial 1080mm	Tubo della presa acciaio raffinato	BUIS 1080 MM INTERN BOILERS ST (INOX)	Pipa del producto acero afinado 1080mm	41
7	8 710 735 187 0	Auslaufrohr Edelstahl 120mm	Outlet tube stainless steel 120mm	Tube de sortie acier spécial 120mm	Tubo di uscita in acciaio 120mm	Stalen uitloopbuisje 120mm	Tubo de salida del producto acero afinar	36
8	8 717 207 280 0	Schalteinsatz	Insert of commutation	Insert de commutation	Quadro comandi	Schakelinzetstuk	Cuadro de mandos	46
9	8 715 506 203 0	Blende	Shield	Cache	Mascherina	Paneel	Chapa cuadro	25
10	8 711 302 082 0	Bügel	Wire form spring	Epingle	Fermo a molla	Borgveer	Clip de fijación	12
11	8 717 206 186 0	Temperaturregler	Flow thermostat	Thermostat	Thermostat	AQUASTAAT MWISSELKONTAKT SO 120-160-200	Regulador de temperatura	36
12	8 713 403 008 0	Schraube (10x)	Screw	Vis (10x)	Vite (10x)	Schroef (10x)	Tornillo (10x)	11
13	8 712 000 034 0	Drehknopf	Rotary handle	Bouton de réglage	Manopola	Regelknop	Botón rotativo	12
15	8 717 301 017 0	Entstörkondensator	ENTSTÖRKONDENSATOR	Condensateur	Condensatore	CONDENSATOR VOOR AQUASTAAT 8 717 206 974	Condensador filtro	14
	8 718 005 381 0	Abdeckung	Covering sheet	Couvercle	Coperchio	Afdichting	Chapa de protección	41

For:





Ersatzteilliste  
Spare parts list  
Liste des pièces de rechange  
Lista parti di ricambio  
Onderdelenlijst  
Lista de repuestos

ST90-2/1E - 7719001643

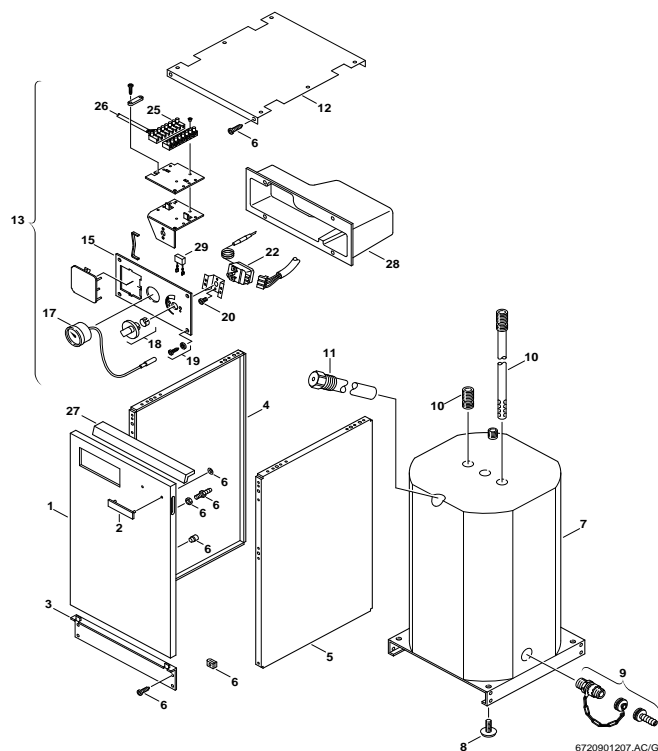

Pos	Bestell-Nr.	Bezeichnung	Description	Dénomination	Descrizione	Benaming	Descripción	PG
1	8 718 006 537 0	Tür	Door	Porte	Panello frontale	Deur	Puerta	46
2	8 701 103 029 0	Warenzeichen	Trade mark badge	Marquage	Targhetta	Fabrieksmerk	Marca	15
3	8 718 005 325 0	Blende	Shield	Cache	Mascherina	Paneel	Chapa cuadro	16
4	8 718 007 212 0	Seitenwand links	Side panel left	Côté gauche	Panello laterale sinistra	Zijpaneel links	Pared lateral a la izquierda	40
5	8 718 007 213 0	Seitenwand rechts	Side panel right	Côté droit	Panello laterale a destra	Zijpaneel rechts	Pared lateral a la derecha	40
6	8 719 918 771 0	Befestigungssatz	Fixing set	Joint de fixation	Set di fissaggio	Bevestigingsset	Juego piezas de fijacion	25
7	8 715 407 157 0	Behälter	Reservoir	Récipient	Sostegno	Reservoir	Déposito	73
8	8 713 401 069 0	Stellfuß	Foot	Pied	Vite	Voet	Pie	21
9	8 738 505 974 0	Ventil	Globe valve	Robinet	Valvola	AFSLUITKRAAN	Válvula de globo	26
10	8 710 735 438 0	Ein-/Auslaufrohr Edelstahl, 1253mm	Inlet/Outlet tube	Tube d'arrivée/évacuation	Tubo della presa/ entrata	Inlet/Outlet tube	Pipa del producto/de salida	41
11	8 709 918 608 0	Anode	Anode	Anode	Anodo	Anode	Anodo	37
12	8 718 006 538 0	Deckel	Cover	Couvercle	Coperchio	Deksel	Tapa	40
15	8 715 506 392 0	Blende	Shield	Cache	Mascherina	Paneel	Chapa cuadro	32
17	8 737 208 991 0	Thermometer	Thermometer	Thermomètre	Termometro	THERMOMETER SO...SK...ZZ-3Z - Z(W)...F	Termómetro	37
18	8 712 000 034 0	Drehknopf	Rotary handle	Bouton de réglage	Manopola	Regelknop	Botón rotativo	12
19	8 713 403 008 0	Schraube (10x)	Screw	Vis (10x)	Vite (10x)	Schroef (10x)	Tornillo (10x)	11
22	8 717 206 186 0	Temperaturregler	Flow thermostat	Thermostat	Thermostat	AQUASTAAT MWISSELKONTAKT SO 120-160-200	Regulador de temperatura	36
25	8 711 006 046 0	Klemmleiste 24V	Terminal strip 24V	Bornier 24V	Cablaggio 24V	Klemmenstrook 24V	Regleta de bornes 24V	08
26	8 714 401 396 0	Kabel	Cable	Faisceau	Cablaggio	Kabel	Cable	23
27	8 718 006 539 0	Winkel	Angle bracket	Equerre	Staffa	Hoeksteun	Angulo	30
28	8 715 503 119 0	Abdeckung	Covering sheet	Couvercle	Coperchio	afdekkap, afdekking	Chapa de protección	33
29	8 717 301 017 0	Entstörkondensator	ENTSTÖRKONDENSATOR	Condensateur	Condensatore	CONDENSATOR VOOR AQUASTAAT 8 737 208 974	Condensador filtro	14

For:

Ersatzteilliste  
 Spare parts list  
 Liste des pièces de rechange  
 Lista parti di ricambio  
 Onderdelenlijst  
 Lista de repuestos

**ST90-2E - 7719000771**

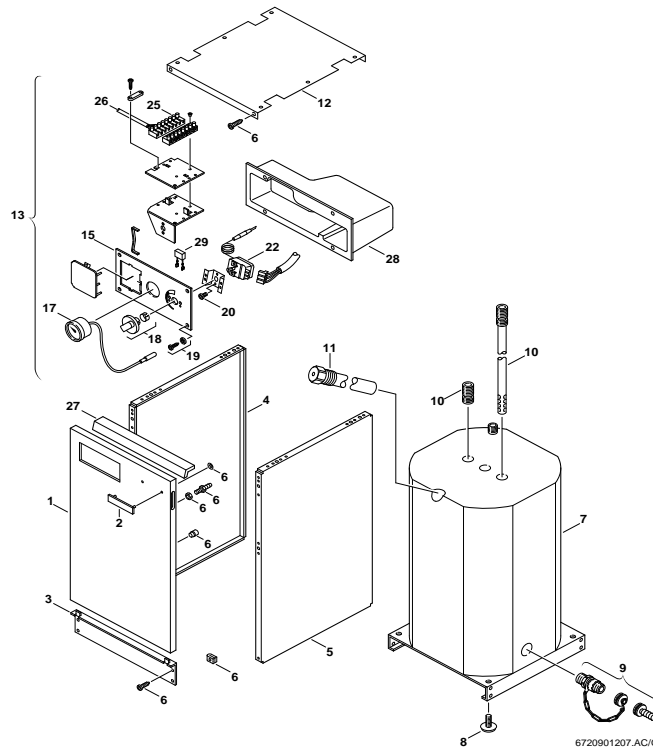

Pos	Bestell-Nr.	Bezeichnung	Description	Dénomination	Descrizione	Benaming	Descripción	PG
1	<b>8 718 006 537 0</b>	Tür	Door	Porte	Pannelo frontale	Deur	Puerta	46
2	<b>8 701 103 029 0</b>	Warenzeichen	Trade mark badge	Marquage	Targhetta	Fabrieksmerk	Marca	15
3	<b>8 718 005 325 0</b>	Blende	Shield	Cache	Mascherina	Paneel	Chapa cuadro	16
4	<b>8 718 007 212 0</b>	Seitenwand links	Side panel left	Côté gauche	Pannelo laterale sinistra	Zijpaneel links	Pared lateral a la izquierda	40
5	<b>8 718 007 213 0</b>	Seitenwand rechts	Side panel right	Côté droit	Pannelo laterale a destra	Zijpaneel rechts	Pared lateral a la derecha	40
6	<b>8 719 918 771 0</b>	Befestigungssatz	Fixing set	Joint de fixation	Set di fissaggio	Bevestigingsset	Juego piezas de fijacion	25
7	<b>8 715 407 157 0</b>	Behälter	Reservoir	Récipient	Sostegno	Reservoir	Déposito	73
8	<b>8 713 401 069 0</b>	Stellfuß	Foot	Pied	Vite	Voet	Pie	21
9	<b>8 738 505 974 0</b>	Ventil	Globe valve	Robinet	Valvola	AFSLUITKRAAN	Válvula de globo	26
10	<b>8 710 735 438 0</b>	Ein-/Auslaufrohr Edelstahl, 1253mm	Inlet/Outlet tube	Tube d'arrivée/évacuation	Tubo della presa/ entrata	Inlet/Outlet tube	Pipa del producto/de salida	41
11	<b>8 709 918 638 0</b>	Anode 1"	Anode 1"	Anode 1"	Anodo 1"	ANODE SK 120/140/160-4ZB	Anodo 1"	37
12	<b>8 718 006 538 0</b>	Deckel	Cover	Couvercle	Coperchio	Deksel	Tapa	40
17	<b>8 737 208 991 0</b>	Thermometer	Thermometer	Thermomètre	Termometro	THERMOMETER SO...SK...22-3Z - Z(W)...F	Termómetro	37
19	<b>8 713 403 008 0</b>	Schraube (10x)	Screw	Vis (10x)	Vite (10x)	Schroef (10x)	Tornillo (10x)	11
22	<b>8 717 206 186 0</b>	Temperaturregler	Flow thermostat	Thermostat	Thermostat	AQUASTAAT MIWISSELKONTAKT SO 120-160-200	Regulador de temperatura	36
25	<b>8 711 006 046 0</b>	Klemmleiste 24V	Terminal strip 24V	Bornier 24V	Cablaggio 24V	Klemmenstrook 24V	Regleta de bornes 24V	08
26	<b>8 714 401 396 0</b>	Kabel	Cable	Faisceau	Cablaggio	Kabel	Cable	23
27	<b>8 718 006 539 0</b>	Winkel	Angle bracket	Equerre	Staffa	Hoeksteun	Angulo	30
28	<b>8 715 503 119 0</b>	Abdeckung	Covering sheet	Couvercle	Coperchio	afdekkap, afdekking	Chapa de protección	33
29	<b>8 717 301 017 0</b>	Entstörkondensator	ENTSTÖRKONDENSATOR	Condensateur	Condensatore	CONDENSATOR VOOR AQUASTAAT 8 737 206 974	Condensador filtro	14

For:

Ersatzteilliste  
 Spare parts list  
 Liste des pièces de rechange  
 Lista parti di ricambio  
 Onderdelenlijst  
 Lista de repuestos

**ST90-3E - 7719002871**

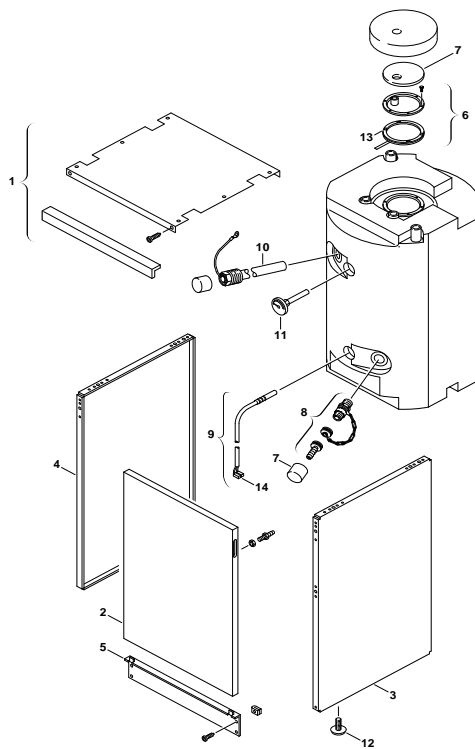

6720901192/G

Pos	Bestell-Nr.	Bezeichnung	Description	Dénomination	Descrizione	Benaming	Descripción	PG
1	8 729 011 029 0	Deckel	Cover	Couvercle	Coperchio	Deksel	Tapa	36
2	8 729 011 026 0	Vorderwand	Cover	Couvercle	Coperchio	Voordeksel	Tapa	35
3	8 729 011 027 0	Seitenwand rechts	Side panel right	Côté droit	Pannelo laterale a destra	Zijpaneel rechts	Pared lateral a la derecha	39
4	8 729 011 028 0	Seitenwand links	Side panel left	Côté gauche	Pannelo laterale sinistra	Zijpaneel links	Pared lateral a la izquierda	39
5	8 729 011 030 0	Blende	Shield	Cache	Mascherina	Paneel	Chapa cuadro	30
6	8 729 011 032 0	Flansch	Connecting flange	Bride de raccordement	Flangia	Aansluitflens	Brida de conexión	39
7	8 729 011 033 0	Isolierung	Insulation	Isolation	Isolamento	Isolatie	Aislamiento	23
8	8 738 505 974 0	Ventil	Globe valve	Robinet	Valvola	AFSLUITKRAAN	Válvula de globo	26
9	8 714 500 034 0	Sensor WW-NTC mit Aderendhülse 6m	Temperature sensor 6mm	SONDE DE TEMPERATURE 6mm	Sensore termometrico 6mm	Temperatuurvoeler 6mm	Sensor de temperatura 6mm	34
10	8 729 011 034 0	Anode	Anode	Anode	Anodo	Anode	Anodo	36
11	8 717 208 050 0	Thermometer	Thermometer	Thermomètre	Termometro	Thermometer	Termómetro	31
12	8 713 401 046 0	Stellfuß	Foot	Pied	Vite	Voet	Pie	13
13	8 710 103 513 0	Dichtung	Washer	Joint	Guarnizione	DICHTING ST 75	Junta	20
14	8 711 006 060 0	Stecker	Plug	Connecteur	Spina	STECKER NTC-VOELER ST...1E/SK 300/ST 75	Anection	16
For:								

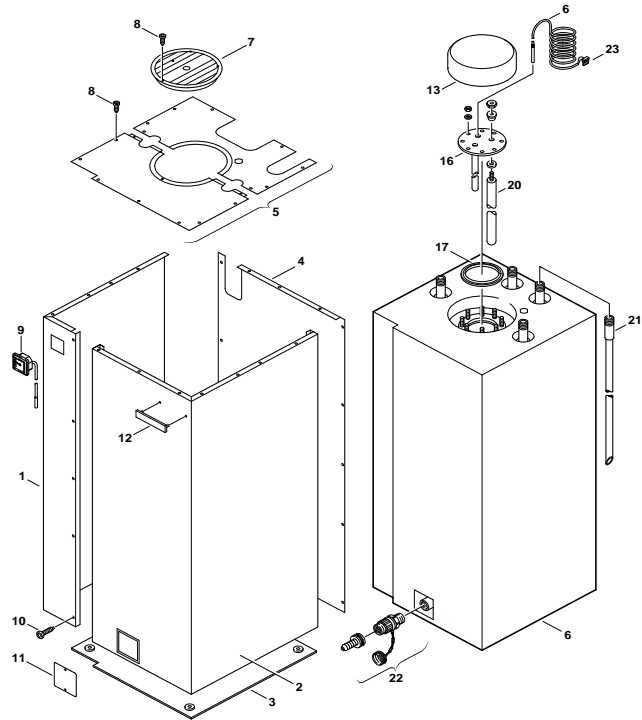
**Ersatzteilliste**
**Spare parts list**
**Liste des pièces de rechange**
**Lista parti di ricambio**
**Onderdelenlijst**
**Lista de repuestos**
**ST110E - 7719001026**

6720901205.AB/G

Pos	Bestell-Nr.	Bezeichnung	Description	Dénomination	Descrizione	Benaming	Descripción	PG
1	8 718 005 478 0	Seitenwand links	Side panel left	Côté gauche	Pannelo laterale sinistra	Zijpaneel links	Pared lateral a la izquierda	55
2	8 718 005 479 0	Seitenwand rechts	Side panel right	Côté droit	Pannelo laterale a destra	Zijpaneel rechts	Pared lateral a la derecha	57
3	8 718 005 480 0	Bodenblech	Oven bottom	Tôle de fond	Lamiera di fondo	Bodemplaat	Chapa de fondo	50
4	8 718 005 481 0	Rückwand	Backpanel	Dossieret	Schienale	Achterwand	Respaldo	53
5	8 718 005 482 0	Abdeckung	Covering sheet	Couvercle	Coperchio	Afdichting	Chapa de protección	52
6	8 714 500 034 0	Sensor WW-NTC mit Aderendhülse 6m	Temperature sensor 6mm	SONDE DE TEMPERATURE 6mm	Sensore termometrico 6mm	Temperatuurvoeler 6mm	Sensor de temperatura 6mm	34
7	8 700 000 046 0	Abdeckung	Covering sheet	Couvercle	Coperchio	Afdichting	Chapa de protección	30
8	8 713 403 008 0	Schraube (10x)	Screw	Vis (10x)	Vite (10x)	Schroef (10x)	Tornillo (10x)	11
9	8 717 208 036 0	Thermometer	Thermometer	Thermomètre	Termometro	THERMOMETER SK...3Z-ST 110-E	Termómetro	37
10	2 910 614 431 0	Schraube 4,8X9,5 (10x)	Screw 4,8X9,5 (10x)	Vis 4,8X9,5 (10x)	Vite 4,8X9,5 (10x)	Schroef 4,8X9,5 (10x)	Tornillo 4,8X9,5 (10x)	11
11	8 715 503 171 0	Deckel	Cover	Couvercle	Coperchio	Deksel	Tapa	38
12	8 701 103 029 0	Warenzeichen	Trade mark badge	Marquage	Targhetta	Fabrieksmerk	Marca	15
13	8 715 503 149 0	Abdeckung	Covering sheet	Couvercle	Coperchio	Afdichting	Chapa de protección	34
16	8 715 705 052 0	Flansch	Connecting flange	Bride de raccordement	Flangia	FLENS ST 110E	Brida de conexión	46
17	8 710 103 512 0	Dichtung	Washer	Joint	Guarnizione	DICHTING ST 110-E	Junta	19
20	8 719 918 767 0	Anode	Anode	Anode	Anodo	Anode	Anodo	41
21	8 710 715 466 0	Einlaufrohr	Inlet tube	Tube d'arrivée	Tube della presa	Toevoerpijp	Pipa del producto	36
22	8 738 505 974 0	Ventil	Globe valve	Robinet	Valvola	AFSLUITKRAAN	Válvula de globo	26
23	8 711 006 060 0	Stecker	Plug	Connecteur	Spina	STECKER NTC-VOELER ST...1ESK 300/ST 75	Anection	16

For:

Ersatzteilliste  
Spare parts list  
Liste des pièces de rechange  
Lista parti di ricambio  
Onderdelenlijst  
Lista de repuestos

# ST120 - 7719000732

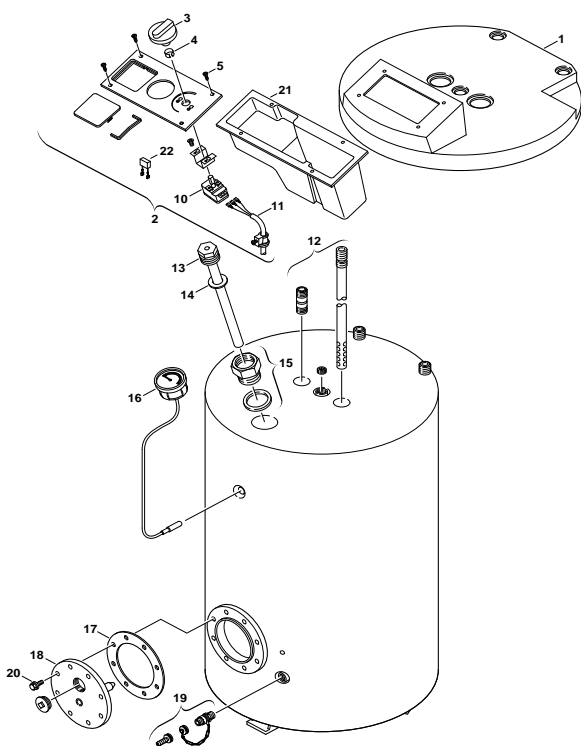

6720901200.AC/G

Pos	Bestell-Nr.	Bezeichnung	Description	Dénomination	Descrizione	Benaming	Descripción	PG
1	8 715 505 411 0	Haube	Hood	Capot	Carpot	Deksel	Capota	36
3	8 712 000 034 0	Drehknopf	Rotary handle	Bouton de réglage	Manopola	Regelknop	Botón rotativo	12
4	8 710 609 006 0	Halter (10x)	Fixing bracket (10x)	Support (10x)	Angolare (10x)	Steunbeugel (10x)	Angulo soporte (10x)	12
10	8 717 206 186 0	Temperaturregler	Flow thermostat	Thermostat	Thermostat	<small>AQUASTAAT M/MSSELKONTAKT SO 120-160-200</small>	Regulador de temperatura	36
11	8 714 401 821 0	Kabel	Cable	Faisceau	Cablaggio	Kabel	Cable	27
12	8 710 735 438 0	<small>Ein-/Auslaufrohr Edelstahl, 1253mm</small>	Inlet/Outlet tube	Tube d'arrivée/évacuation	Tube della presa/ entrata	Inlet/Outlet tube	Pipa del producto/de salida	41
13	8 709 918 505 0	Anode	Anode	Anode	Anodo	<small>ANODE SO 120-SK 130/22-ST 120</small>	Anodo	39
14	8 710 103 086 0	Dichtscheibe (10x)	Washer (10x)	Joint (10x)	Guarnizione (10x)	<small>DICHTING ANODE VOOR SO 160</small>	Junta (10x)	22
16	8 737 208 991 0	Thermometer	Thermometer	Thermomètre	Termometro	<small>THERMOMETER SO...SK...22-32 - Z(W)... F</small>	Termómetro	37
19	8 738 505 974 0	Ventil	Globe valve	Robinet	Valvola	AFSLUITKRAAN	Válvula de globo	26
21	8 715 503 119 0	Abdeckung	Covering sheet	Couvercle	Coperchio	afdekkap, afdekking	Chapa de protección	33
22	8 717 301 017 0	Entstörkondensator	ENTSTÖRKONDENSATOR	Condensateur	Condensatore	<small>CONDENSATOR VOOR AQUASTAAT 8 737 206 974</small>	Condensador filtro	14

For:

**Ersatzteilliste**  
**Spare parts list**  
**Liste des pièces de rechange**  
**Lista parti di ricambio**  
**Onderdelenlijst**  
**Lista de repuestos**

# ST120-1E - 7719001311

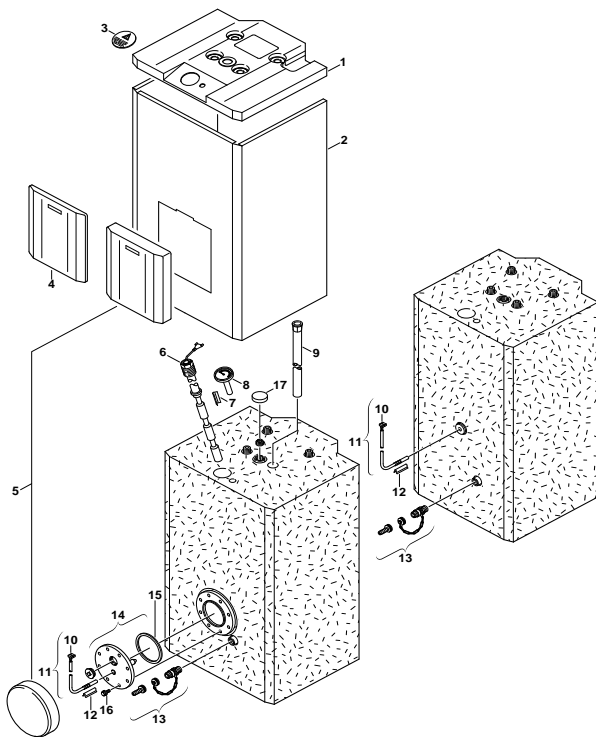

6720901198 AC/G

Pos	Bestell-Nr.	Bezeichnung	Description	Dénomination	Descrizione	Benaming	Descripción	PG
1	8 715 503 236 0	Haube grau	Hood grey	Capot gris	Carpot grigio	BOVENDEKSEL ST 120-1E	Capota girar	41
2	8 715 401 293 0	Mantel weiß	Front shell white	Habillage blanc	Mantello bianco	Mantel wit	Carcasa blanco	53
3	8 715 503 238 0	Abdeckung grau	Covering sheet grey	Couvercle gris	Coperchio grigio	ZELFKLEVER ST 120/160-1E	Chapa de protección girar	23
4	8 715 503 237 0	Abdeckung grau	Covering sheet grey	Couvercle gris	Coperchio grigio	Afdichting grijs	Chapa de protección girar	39
6	8 709 918 666 0	Anode 1"	Anode 1"	Anode 1"	Anodo 1"	ANODE (KETTING) ST120/160-1E /SK 130-3Z	Anodo 1"	43
7	8 714 606 024 0	Klemmfeder	Clamp spring	RESSORT POUR THERMOMETRE	Fermo	KLEMVEER V/THERMOMETER ST/SO	Muelle fijación	20
8	8 717 208 050 0	Thermometer	Thermometer	Thermomètre	Termometro	Thermometer	Termómetro	31
9	8 710 735 442 0	Einlaufrohr Edelstahl 850mm	Inlet tube stainless steel 850mm	Tube d'arrivée acier spécial 850mm	Tubo della presa acciaio raffinato 850mm	BUIS 850 MM INTERNE BOILERS (INOX)	Pipa del producto acero afinado 850mm	38
10	8 711 006 060 0	Stecker	Plug	Connecteur	Spina	STEKKER NTC-VOELER ST...1E/SK 300/ST 75	Aneccion	16
11	8 714 500 034 0	Sensor WW-NTC mit Aderendhülse 6m	Temperature sensor 6mm	SONDE DE TEMPERATURE 6mm	Sensore termometrico 6mm	Temperatuurvoeler 6mm	Sensor de temperatura 6mm	34
12	8 714 606 021 0	Klemmfeder	Clamp spring	Ressort	Fermo	KLEMVEER NTC SK120/140/160-4ZB	Muelle de tecla	25
13	8 738 505 974 0	Ventil	Globe valve	Robinet	Valvola	AFSLUITKRAAN	Válvula de globo	26
17	8 715 503 239 0	Isolierung	Insulation	Bouchon	Isolamento	ISOLATIE SK 300-1 SOLAR (7719001929)	Aislamiento	23
For:								

Ersatzteilliste  
Spare parts list  
Liste des pièces de rechange  
Lista parti di ricambio  
Onderdelenlijst  
Lista de repuestos

# ST120-1E - 7719002872

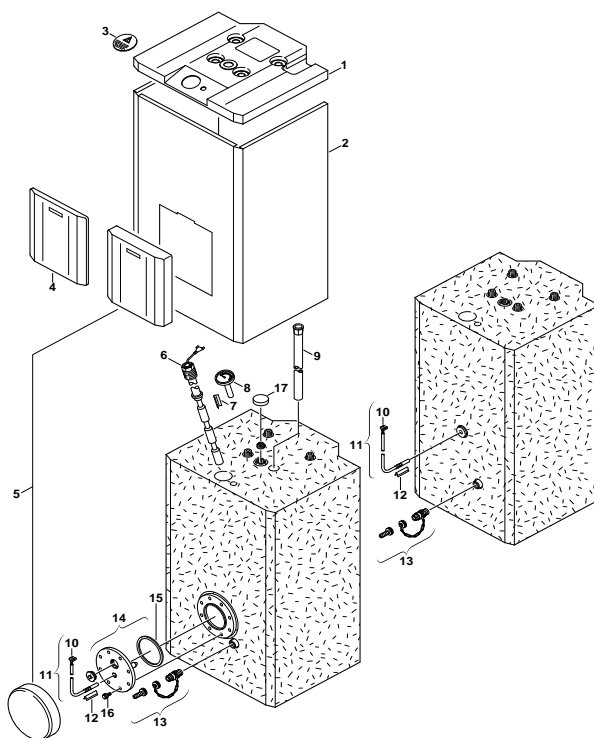

6720901198 AC/G

Pos	Bestell-Nr.	Bezeichnung	Description	Dénomination	Descrizione	Benaming	Descripción	PG
1	8 715 503 369 0	Haube hellgrau	Hood light grey	Carpot gris clair	Coperchio grigio chiaro	DEKSEL ST 120-1E/C1	Capota girar claro	41
2	8 715 401 293 0	Mantel weiß	Front shell white	Habillage blanc	Mantello bianco	Mantel wit	Carcasa blanco	53
3	8 715 503 372 0	Abdeckung hellgrau	Covering sheet light grey	Couvercle gris clair	Coperchio grigio chiaro	Afdichting lichtgrijs	Chapa de protección girar claro	30
4	8 715 503 397 0	Abdeckung hellgrau	Covering sheet light grey	Couvercle gris clair	Coperchio grigio chiaro	Afdichting lichtgrijs	Chapa de protección girar claro	41
6	8 709 918 666 0	Anode 1"	Anode 1"	Anode 1"	Anodo 1"	ANODE (KETTING) ST120/160-1E /SK 130-3Z	Anodo 1"	43
7	8 714 606 024 0	Klemmfeder	Clamp spring	RESSORT POUR THERMOMETRE	Fermo	KLEMVEER W/THERMOMETER ST/SO	Muelle fijación	20
8	8 717 208 050 0	Thermometer	Thermometer	Thermomètre	Termometro	Thermometer	Termómetro	31
9	8 710 735 442 0	Einlaufrohr Edelstahl 850mm	Inlet tube stainless steel 850mm	Tube d'arrivée acier spécial 850mm	Tubo della presa acciaio raffinato 850mm	BUIS 850 MM INTERNE BOILERS (INOX)	Pipa del producto acero afinado 850mm	38
10	8 711 006 060 0	Stecker	Plug	Connecteur	Spina	STEKKER NTC-VOELER ST...1E/SK 300/ST 75	Anection	16
11	8 714 500 034 0	Sensor WW-NTC mit Aderendhülse 6m	Temperature sensor 6mm	SONDE DE TEMPERATURE 6mm	Sensore termometrico 6mm	Temperatuurvoeler 6mm	Sensor de temperatura 6mm	34
12	8 714 606 021 0	Klemmfeder	Clamp spring	Ressort	Fermo	KLEMVEER NTC SK120/140/160-4ZB	Muelle de tecla	25
13	8 738 505 974 0	Ventil	Globe valve	Robinet	Valvola	AFSLUITKRAAN	Válvula de globo	26
17	8 715 503 239 0	Isolierung	Insulation	Bouchon	Isolamento	ISOLATIE SK 300-1 SOLAR (7719001929)	Aislamiento	23

For:

Ersatzteilliste  
 Spare parts list  
 Liste des pièces de rechange  
 Lista parti di ricambio  
 Onderdelenlijst  
 Lista de repuestos

# ST120-1E S5300 - 7719001818

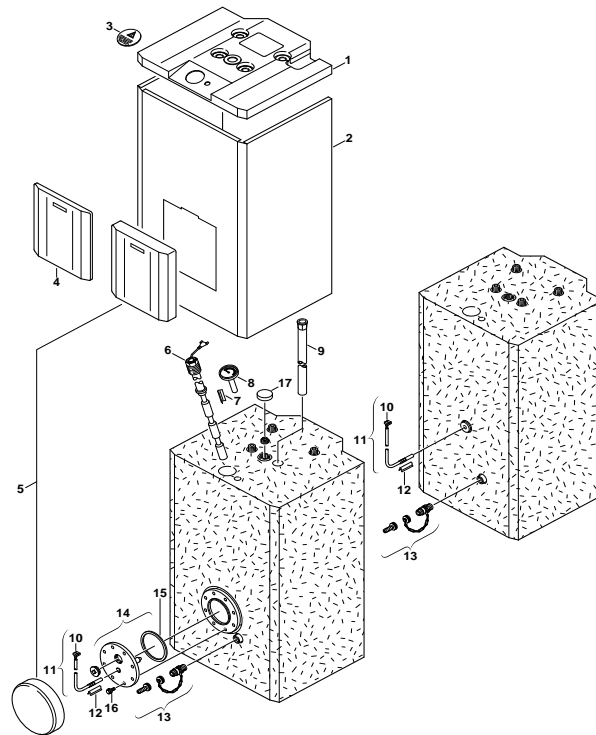

6720901198 AC/G

Pos	Bestell-Nr.	Bezeichnung	Description	Dénomination	Descrizione	Benaming	Descripción	PG
1	8 715 503 369 0	Haube hellgrau	Hood light grey	Carpot gris clair	Coperchio grigio chiaro	DEKSEL ST 120-1E/C1	Capota girar claro	41
2	8 715 401 293 0	Mantel weiß	Front shell white	Habillage blanc	Mantello bianco	Mantel wit	Carcasa blanco	53
3	8 715 503 372 0	Abdeckung hellgrau	Covering sheet light grey	Couvercle gris clair	Coperchio grigio chiaro	Afdichting lichtgrijs	Chapa de protección girar claro	30
4	8 715 503 397 0	Abdeckung hellgrau	Covering sheet light grey	Couvercle gris clair	Coperchio grigio chiaro	Afdichting lichtgrijs	Chapa de protección girar claro	41
6	8 709 918 666 0	Anode 1"	Anode 1"	Anode 1"	Anodo 1"	ANODE (KETTING) ST120/160-1E /SK 130-3Z	Anodo 1"	43
7	8 714 606 024 0	Klemmfeder	Clamp spring	RESSORT POUR THERMOMETRE	Fermo	KLEMVEER V/THERMOMETER ST/SO	Muelle fijación	20
8	8 717 208 050 0	Thermometer	Thermometer	Thermomètre	Termometro	Thermometer	Termómetro	31
9	8 710 735 442 0	Einlaufrohr Edelstahl 850mm	Inlet tube stainless steel 850mm	Tube d'arrivée acier spécial 850mm	Tubo della presa acciaio raffinato 850mm	BUIS 850 MM INTERNE BOILERS (INOX)	Pipa del producto acero afinado 850mm	38
10	8 711 006 060 0	Stecker	Plug	Connecteur	Spina	STEKKER NTC-VOELER ST.-1E/SK 300/ST 75	Anection	16
11	8 714 500 034 0	Sensor WW-NTC mit Aderendhülse 6m	Temperature sensor 6mm	SONDE DE TEMPERATURE 6mm	Sensore termometrico 6mm	Temperatuurvoeler 6mm	Sensor de temperatura 6mm	34
12	8 714 606 021 0	Klemmfeder	Clamp spring	Ressort	Fermo	KLEMVEER NTC SK120/140/160-4ZB	Muelle de tecla	25
13	8 738 505 974 0	Ventil	Globe valve	Robinet	Valvola	AFSLUITKRAAN	Válvula de globo	26
17	8 715 503 239 0	Isolierung	Insulation	Bouchon	Isolamento	ISOLATIE SK 300-1 SOLAR (7719001929)	Aislamiento	23
For:								





Ersatzteilliste  
Spare parts list  
Liste des pièces de rechange  
Lista parti di ricambio  
Onderdelenlijst  
Lista de repuestos

ST120-1EB - 7719001312

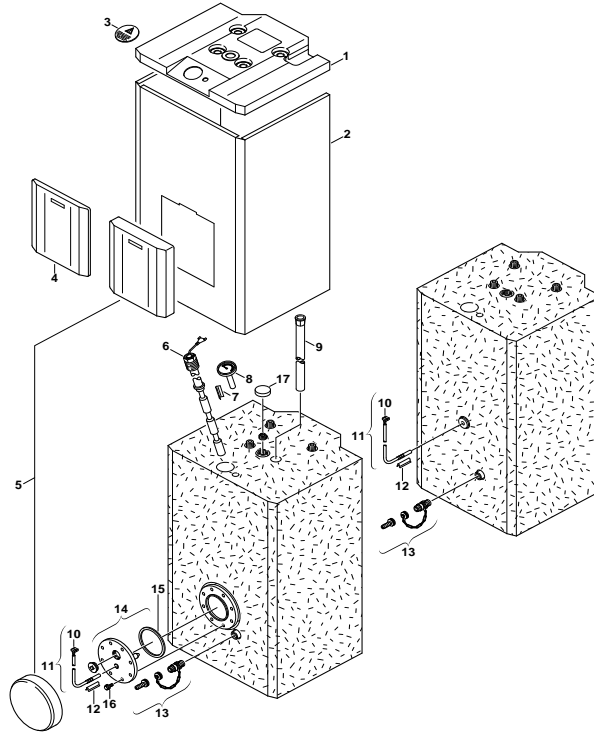

6720901198 AC/G

Pos	Bestell-Nr.	Bezeichnung	Description	Dénomination	Descrizione	Benaming	Descripción	PG
1	8 715 503 236 0	Haube grau	Hood grey	Capot gris	Carpot grigio	BOVENDEKSEL ST 120-1E	Capota girar	41
2	8 715 401 294 0	Mantel weiß	Outer_case Withe	Outer_case Withe	Outer_case Withe	Outer_case Withe	Outer_case Withe	53
3	8 715 503 238 0	Abdeckung grau	Covering sheet grey	Couvercle gris	Coperchio grigio	ZELFKLEVER ST 120/160-1E	Chapa de protección girar	23
5	8 715 503 240 0	Abdeckung grau	Covering sheet grey	Couvercle gris	Coperchio grigio	Afdichting grijs	Chapa de protección girar	39
6	8 709 918 666 0	Anode 1"	Anode 1"	Anode 1"	Anodo 1"	ANODE (KETTING) ST120/160-1E /SK 130-3Z	Anodo 1"	43
7	8 714 606 024 0	Klemmfeder	Clamp spring	RESSORT POUR THERMOMETRE	Fermo	KLEMVEER W/THERMOMETER ST/SO	Muelle fijación	20
8	8 717 208 050 0	Thermometer	Thermometer	Thermomètre	Termometro	Thermometer	Termómetro	31
9	8 710 735 442 0	Einlaufrohr Edelstahl 850mm	Inlet tube stainless steel 850mm	Tube d'arrivée acier spécial 850mm	Tubo della presa acciaio raffinato 850mm	BUIS 850 MM INTERNE BOILERS (INOX)	Pipa del producto acero afinado 850mm	38
10	8 711 006 060 0	Stecker	Plug	Connecteur	Spina	STEKKER NTC-VOELER ST...1E/SK 300/ST 75	Anection	16
11	8 714 500 034 0	Sensor WW-NTC mit Aderendhülse 6m	Temperature sensor 6mm	SONDE DE TEMPERATURE 6mm	Sensore termometrico 6mm	Temperatuurvoeler 6mm	Sensor de temperatura 6mm	34
12	8 714 606 021 0	Klemmfeder	Clamp spring	Ressort	Fermo	KLEMVEER NTC SK120/140/160-4ZB	Muelle de tecla	25
13	8 738 505 974 0	Ventil	Globe valve	Robinet	Valvola	AFSLUITKRAAN	Válvula de globo	26
14	8 715 503 241 0	Flanschdeckel	Flange cover	Couvercle de bride de racc.	Flangia bollitore	Flensdeksel	Tapa reborde	47
15	8 710 103 096 0	Dichtungs-Set 100x109D - 115/138Dx3 (1x)	Set of seals 100x109D - 115/138Dx3 (1x)	Jeu de joints 100x109D - 115/138Dx3 (1x)	Set guarnizioni 100x109D - 115/138Dx3	DICHTING FLENS SK...2ZB/3ZB (VANAF 070)	conjunto de juntas 100x109D - 115/138Dx3	23
16	2 911 060 291 0	Schraube M10x25 (10x)	Screw M10x25 (10x)	Vis M10x25 (10x)	Vite M10x25 (10x)	Schroef M10x25 (10x)	Tornillo M10x25 (10x)	18
16	2 911 060 342 0	Schraube M12x30 (10x)	Screw M12x30 (10x)	Vis M12x30 (10x)	Vite M12x30 (10x)	Schroef M12x30 (10x)	Tornillo M12x30 (10x)	16

For:

Ersatzteilliste  
Spare parts list  
Liste des pièces de rechange  
Lista parti di ricambio  
Onderdelenlijst  
Lista de repuestos

# ST120-1EB/C1 - 7719002096

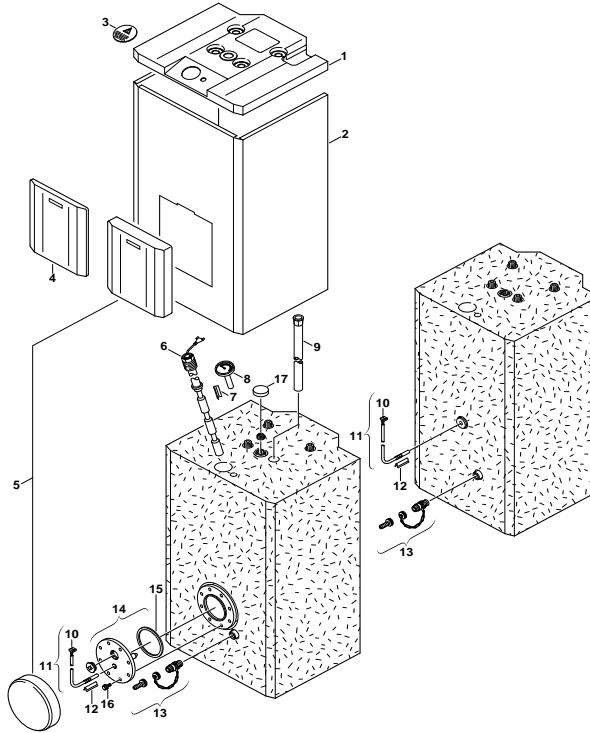

6720901198 AC/G

Pos	Bestell-Nr.	Bezeichnung	Description	Dénomination	Descrizione	Benaming	Descripción	PG
1	8 715 503 369 0	Haube hellgrau	Hood light grey	Carpot gris clair	Coperchio grigio chiaro	DEKSEL ST 120-1E/C1	Capota girar claro	41
2	8 715 401 294 0	Mantel weiß	Outer_case Withe	Outer_case Withe	Outer_case Withe	Outer_case Withe	Outer_case Withe	53
3	8 715 503 372 0	Abdeckung hellgrau	Covering sheet light grey	Couvercle gris clair	Coperchio grigio chiaro	Afdichting lichtgrijs	Chapa de protección girar claro	30
5	8 715 503 368 0	Abdeckung hellgrau	Covering sheet light grey	Couvercle gris clair	Coperchio grigio chiaro	Afdichting lichtgrijs	Chapa de protección girar claro	39
6	8 709 918 666 0	Anode 1"	Anode 1"	Anode 1"	Anodo 1"	ANODE (KETTING) ST120/160-1E /SK 130-3Z	Anodo 1"	43
7	8 714 606 024 0	Klemmfeder	Clamp spring	RESSORT POUR THERMOMETRE	Fermo	KLEMVEER W/THERMOMETER ST/ISO	Muelle fijación	20
8	8 717 208 050 0	Thermometer	Thermometer	Thermomètre	Termometro	Thermometer	Termómetro	31
9	8 710 735 442 0	Einlaufrohr Edelstahl 850mm	Inlet tube stainless steel 850mm	Tube d'arrivée acier spécial 850mm	Tubo della presa acciaio raffinato 850mm	BUIS 850 MM INTERNE BOILERS (INOX)	Pipa del producto acero afinado 850mm	38
10	8 711 006 060 0	Stecker	Plug	Connecteur	Spina	STEKKER NTC-VOELER ST.-1E/SK 300/ST 75	Anection	16
11	8 714 500 034 0	Sensor WW-NTC mit Aderendhülse 6m	Temperature sensor 6mm	SONDE DE TEMPERATURE 6mm	Sensore termometrico 6mm	Temperatuurvoeler 6mm	Sensor de temperatura 6mm	34
12	8 714 606 021 0	Klemmfeder	Clamp spring	Ressort	Fermo	KLEMVEER NTC SK120/140/160-4ZB	Muelle de tecla	25
13	8 738 505 974 0	Ventil	Globe valve	Robinet	Valvola	AFSLUITKRAAN	Válvula de globo	26
14	8 715 503 241 0	Flanschdeckel	Flange cover	Couvercle de bride de racc.	Flangia bollitore	Flensdeksel	Tapa reborde	47
15	8 710 103 096 0	Dichtungs-Set 100x109D - 115/138Dx3 (1x)	Set of seals 100x109D - 115/138Dx3 (1x)	Jeu de joints 100x109D - 115/138Dx3 (1x)	Set guarnizioni 100x109D - 115/138Dx3	DICHTING FLENS SK...22B/-3ZB (VANAF 070)	conjunto de juntas 100x109D - 115/138Dx3	23
16	2 911 060 291 0	Schraube M10x25 (10x)	Screw M10x25 (10x)	Vis M10x25 (10x)	Vite M10x25 (10x)	Schroef M10x25 (10x)	Tornillo M10x25 (10x)	18
16	2 911 060 342 0	Schraube M12x30 (10x)	Screw M12x30 (10x)	Vis M12x30 (10x)	Vite M12x30 (10x)	Schroef M12x30 (10x)	Tornillo M12x30 (10x)	16
17	8 715 503 239 0	Isolierung	Insulation	Bouchon	Isolamento	ISOLATIE SK 300-1 SOLAR (7719001929)	Aislamiento	23

For:

Ersatzteilliste  
 Spare parts list  
 Liste des pièces de rechange  
 Lista parti di ricambio  
 Onderdelenlijst  
 Lista de repuestos

**ST120-1EO - 7719001364**

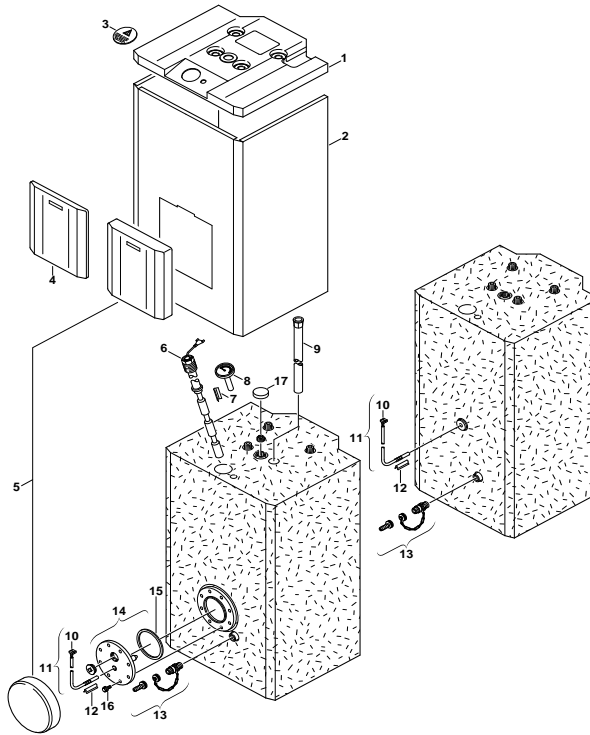

6720901198 AC/G

Pos	Bestell-Nr.	Bezeichnung	Description	Dénomination	Descrizione	Benaming	Descripción	PG
1	8 715 503 236 0	Haube grau	Hood grey	Capot gris	Carpot grigio	BOVENDEKSEL ST 120-1E	Capota girar	41
3	8 715 503 238 0	Abdeckung grau	Covering sheet grey	Couvercle gris	Coperchio grigio	ZELFKLEVER ST 120/160-1E	Chapa de protección girar	23
6	8 709 918 666 0	Anode 1"	Anode 1"	Anode 1"	Anodo 1"	ANODE (KETTING) ST120/160-1E /SK 130-3Z	Anodo 1"	43
7	8 714 606 024 0	Klemmfeder	Clamp spring	RESSORT POUR THERMOMETRE	Fermo	KLEMVEER V/THERMOMETER ST/ISO	Muelle fijación	20
8	8 717 208 050 0	Thermometer	Thermometer	Thermomètre	Termometro	Thermometer	Termómetro	31
9	8 710 735 442 0	Einlaufrohr Edelstahl 850mm	Inlet tube stainless steel 850mm	Tube d'arrivée acier spécial 850mm	Tubo della presa acciaio raffinato 850mm	BUIS 850 MM INTERNE BOILERS (INOX)	Pipa del producto acero afinado 850mm	38
10	8 711 006 060 0	Stecker	Plug	Connecteur	Spina	STEKKER NTC-VOELER ST.-1E/SK 300/ST 75	Anection	16
11	8 714 500 034 0	Sensor WW-NTC mit Aderendhülse 6m	Temperature sensor 6mm	SONDE DE TEMPERATURE 6mm	Sensore termometrico 6mm	Temperatuurvoeler 6mm	Sensor de temperatura 6mm	34
12	8 714 606 021 0	Klemmfeder	Clamp spring	Ressort	Fermo	KLEMVEER NTC SK120/140/160-4ZB	Muelle de tecla	25
13	8 738 505 974 0	Ventil	Globe valve	Robinet	Valvola	AFLSLUITKRAAN	Válvula de globo	26
17	8 715 503 239 0	Isolierung	Insulation	Bouchon	Isolamento	ISOLATIE SK 300-1 SOLAR (7719001929)	Aislamiento	23

For:

Ersatzteilliste  
Spare parts list  
Liste des pièces de rechange  
Lista parti di ricambio  
Onderdelenlijst  
Lista de repuestos

# ST120-1EOB - 7719001365

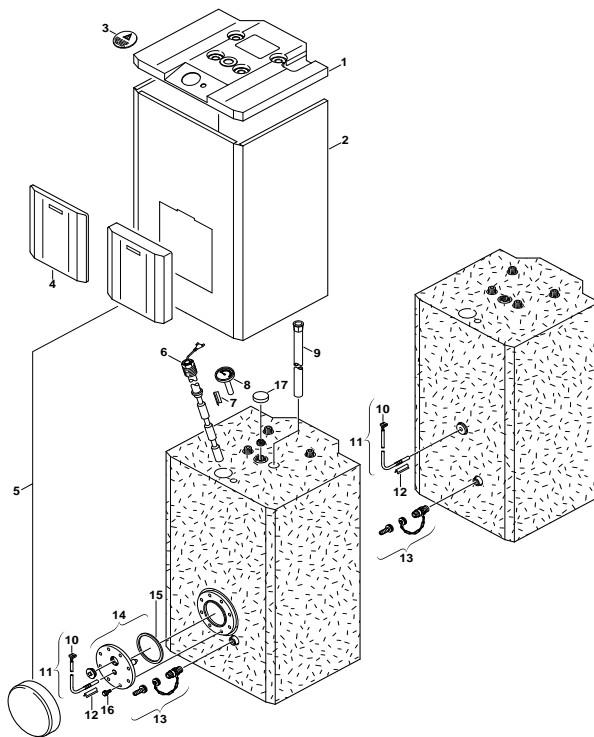

6720901198 AC/G

Pos	Bestell-Nr.	Bezeichnung	Description	Dénomination	Descrizione	Benaming	Descripción	PG
1	8 715 503 236 0	Haube grau	Hood grey	Capot gris	Carpot grigio	BOVENDEKSEL ST 120-1E	Capota girar	41
3	8 715 503 238 0	Abdeckung grau	Covering sheet grey	Couvercle gris	Coperchio grigio	ZELFKLEVER ST 120/160-1E	Chapa de protección girar	23
6	8 709 918 666 0	Anode 1"	Anode 1"	Anode 1"	Anodo 1"	ANODE (KETTING) ST120/160-1E /SK 130-3Z	Anodo 1"	43
7	8 714 606 024 0	Klemmfeder	Clamp spring	RESSORT POUR THERMOMETRE	Fermo	KLEMVEER V/THERMOMETER ST/ISO	Muelle fijación	20
8	8 717 208 050 0	Thermometer	Thermometer	Thermomètre	Termometro	Thermometer	Termómetro	31
9	8 710 735 442 0	Einlaufrohr Edelstahl 850mm	Inlet tube stainless steel 850mm	Tube d'arrivée acier spécial 850mm	Tubo della presa acciaio raffinato 850mm	BUIS 850 MM INTERNE BOILERS (INOX)	Pipa del producto acero afinado 850mm	38
10	8 711 006 060 0	Stecker	Plug	Connecteur	Spina	STEKKER NTC-VOELER ST.-1E/SK 300/ST 75	Aneccion	16
11	8 714 500 034 0	Sensor WW-NTC mit Aderendhülse 6m	Temperature sensor 6mm	SONDE DE TEMPERATURE 6mm	Sensore termometrico 6mm	Temperatuurvoeler 6mm	Sensor de temperatura 6mm	34
12	8 714 606 021 0	Klemmfeder	Clamp spring	Ressort	Fermo	KLEMVEER NTC SK120/140/160-4ZB	Muelle de tecla	25
13	8 738 505 974 0	Ventil	Globe valve	Robinet	Valvola	AFSLUITKRAAN	Válvula de globo	26
14	8 715 503 241 0	Flanschdeckel	Flange cover	Couvercle de bride de racc.	Flangia bollitore	Flensdeksel	Tapa reborde	47
15	8 710 103 096 0	Dichtungs-Set 100x109D - 115/138Dx3 (1x)	Set of seals 100x109D - 115/138Dx3 (1x)	Jeu de joints 100x109D - 115/138Dx3 (1x)	Set guarnizioni 100x109D - 115/138Dx3	DICHTING FLENS SK...2ZB/3ZB (VANAF 070)	conjunto de juntas 100x109D - 115/138Dx3	23
16	2 911 060 291 0	Schraube M10x25 (10x)	Screw M10x25 (10x)	Vis M10x25 (10x)	Vite M10x25 (10x)	Schroef M10x25 (10x)	Tornillo M10x25 (10x)	18
16	2 911 060 342 0	Schraube M12x30 (10x)	Screw M12x30 (10x)	Vis M12x30 (10x)	Vite M12x30 (10x)	Schroef M12x30 (10x)	Tornillo M12x30 (10x)	16

For:

Ersatzteilliste  
Spare parts list  
Liste des pièces de rechange  
Lista parti di ricambio  
Onderdelenlijst  
Lista de repuestos

# ST120-1ES0200/C1 - 7719002093

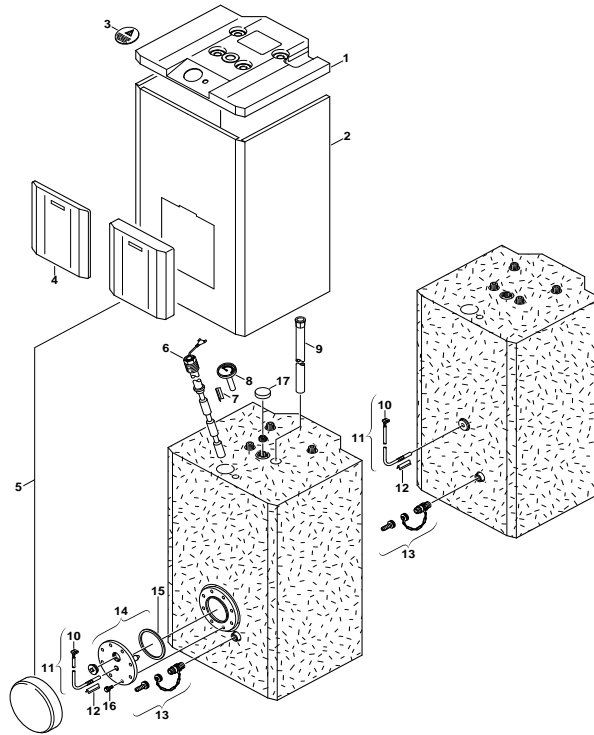

6720901198 AC/G

Pos	Bestell-Nr.	Bezeichnung	Description	Dénomination	Descrizione	Benaming	Descripción	PG
1	8 715 503 369 0	Haube hellgrau	Hood light grey	Carpot gris clair	Coperchio grigio chiaro	DEKSEL ST 120-1E/C1	Capota girar claro	41
2	8 715 401 293 0	Mantel weiß	Front shell white	Habillage blanc	Mantello bianco	Mantel wit	Carcasa blanco	53
3	8 715 503 372 0	Abdeckung hellgrau	Covering sheet light grey	Couvercle gris clair	Coperchio grigio chiaro	Afdichting lichtgrijs	Chapa de protección girar claro	30
4	8 715 503 397 0	Abdeckung hellgrau	Covering sheet light grey	Couvercle gris clair	Coperchio grigio chiaro	Afdichting lichtgrijs	Chapa de protección girar claro	41
6	8 709 918 666 0	Anode 1"	Anode 1"	Anode 1"	Anodo 1"	ANODE (KETTING) ST120/160-1E /SK 130-3Z	Anodo 1"	43
7	8 714 606 024 0	Klemmfeder	Clamp spring	RESSORT POUR THERMOMETRE	Fermo	KLEMVEER V/THERMOMETRE ST/SO	Muelle fijación	20
8	8 717 208 050 0	Thermometer	Thermometer	Thermomètre	Termometro	Thermometer	Termómetro	31
9	8 710 735 442 0	Einlaufrohr Edelstahl 850mm	Inlet tube stainless steel 850mm	Tube d'arrivée acier spécial 850mm	Tubo della presa acciaio raffinato 850mm	BUIS 850 MM INTERNE BOILERS (INOX)	Pipa del producto acero afinado 850mm	38
10	8 711 006 060 0	Stecker	Plug	Connecteur	Spina	STEKKER NTC-VOELER ST.-1E/SK 300/ST 75	Anection	16
11	8 714 500 034 0	Sensor WW-NTC mit Aderendhülse 6m	Temperature sensor 6mm	SONDE DE TEMPERATURE 6mm	Sensore termometrico 6mm	Temperatuurvoeler 6mm	Sensor de temperatura 6mm	34
12	8 714 606 021 0	Klemmfeder	Clamp spring	Ressort	Fermo	KLEMVEER NTC SK120/140/160-4ZB	Muelle de tecla	25
13	8 738 505 974 0	Ventil	Globe valve	Robinet	Valvola	AFSLUITKRAAN	Válvula de globo	26
17	8 715 503 239 0	Isolierung	Insulation	Bouchon	Isolamento	ISOLATIE SK 300-1 SOLAR (7719001929)	Aislamiento	23
For:								

Ersatzteilliste  
Spare parts list  
Liste des pièces de rechange  
Lista parti di ricambio  
Onderdelenlijst  
Lista de repuestos

# ST120-1ES3500/C1 - 7719001472

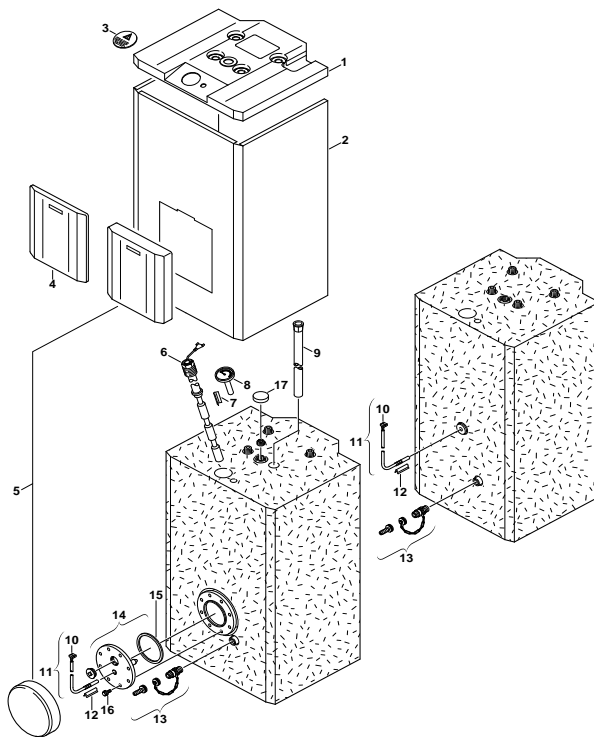

6720901198 AC/G

Pos	Bestell-Nr.	Bezeichnung	Description	Dénomination	Descrizione	Benaming	Descripción	PG
1	8 715 503 369 0	Haube hellgrau	Hood light grey	Carpot gris clair	Coperchio grigio chiaro	DEKSEL ST 120-1E/C1	Capota girar claro	41
2	8 715 401 293 0	Mantel weiß	Front shell white	Habillage blanc	Mantello bianco	Mantel wit	Carcasa blanco	53
3	8 715 503 372 0	Abdeckung hellgrau	Covering sheet light grey	Couvercle gris clair	Coperchio grigio chiaro	Afdichting lichtgrijs	Chapa de protección girar claro	30
4	8 715 503 397 0	Abdeckung hellgrau	Covering sheet light grey	Couvercle gris clair	Coperchio grigio chiaro	Afdichting lichtgrijs	Chapa de protección girar claro	41
6	8 709 918 666 0	Anode 1"	Anode 1"	Anode 1"	Anodo 1"	ANODE (KETTING) ST120/160-1E /SK 130-3Z	Anodo 1"	43
7	8 714 606 024 0	Klemmfeder	Clamp spring	RESSORT POUR THERMOMETRE	Fermo	KLEMVEER W/THERMOMETER ST/ISO	Muelle fijación	20
8	8 717 208 050 0	Thermometer	Thermometer	Thermomètre	Termometro	Thermometer	Termómetro	31
9	8 710 735 442 0	Einlaufrohr Edelstahl 850mm	Inlet tube stainless steel 850mm	Tube d'arrivée acier spécial 850mm	Tubo della presa acciaio raffinato 850mm	BUIS 850 MM INTERNE BOILERS (INOX)	Pipa del producto acero afinado 850mm	38
10	8 711 006 060 0	Stecker	Plug	Connecteur	Spina	STEKKER NTC-VOELER ST.-1E/SK 300/ST 75	Anection	16
11	8 714 500 034 0	Sensor WW-NTC mit Aderendhülse 6m	Temperature sensor 6mm	SONDE DE TEMPERATURE 6mm	Sensore termometrico 6mm	Temperatuurvoeler 6mm	Sensor de temperatura 6mm	34
12	8 714 606 021 0	Klemmfeder	Clamp spring	Ressort	Fermo	KLEMVEER NTC SK120/140/160-4ZB	Muelle de tecla	25
13	8 738 505 974 0	Ventil	Globe valve	Robinet	Valvola	AFSLUITKRAAN	Válvula de globo	26
17	8 715 503 239 0	Isolierung	Insulation	Bouchon	Isolamento	ISOLATIE SK 300-1 SOLAR (7719001929)	Aislamiento	23
	7 709 500 048	Rückschlagventil 3/4"	Non-return valve 3/4"	Soupape de non-retour 3/4"	Valvola di non ritorno 3/4"	Terugslagklep 3/4"	válvula de retención 3/4"	
	7 709 500 052	Überdruckventil 1/2*3/4" 10 bar	VÁLVULA SEG. 1/2*3/4" 10 bar	VÁLVULA SEG. 1/2*3/4" 10 bar	Valvola di sovrappressione 1/2*3/4" 10 bar	Overdrukvelligheid 1/2*3/4" 10 bar	VÁLVULA SEG. 1/2*3/4" 10 bar	

For:





Ersatzteilliste  
 Spare parts list  
 Liste des pièces de rechange  
 Lista parti di ricambio  
 Onderdelenlijst  
 Lista de repuestos

**ST120-1Z S5300 - 7719002447**

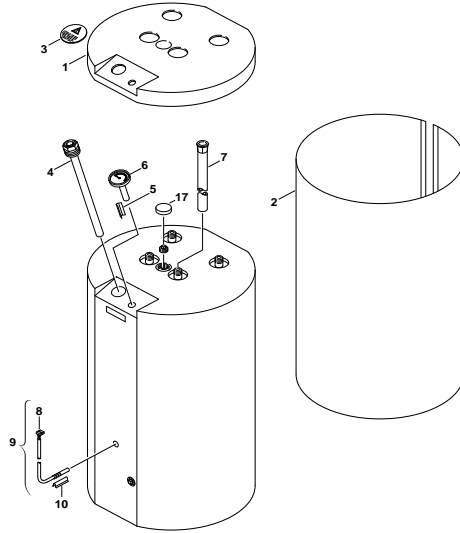

6720901191.AC/G

Pos	Bestell-Nr.	Bezeichnung	Description	Dénomination	Descrizione	Benaming	Descripción	PG
1	8 715 503 371 0	Haube hellgrau	Hood light grey	Carpot gris clair	Coperchio grigio chiaro	Deksel lichtgrijs	Capota girar claro	42
2	8 715 401 361 0	Mantel	Shell	Habillage	Mantello	Mantel	Carcasa	48
3	8 715 503 372 0	Abdeckung hellgrau	Covering sheet light grey	Couvercle gris clair	Coperchio grigio chiaro	Afdichting lichtgrijs	Chapa de protección girar claro	30
4	8 709 918 638 0	Anode 1"	Anode 1"	Anode 1"	Anodo 1"	ANODE SK 120/140/160-4ZB	Anodo 1"	37
5	8 714 606 024 0	Klemmfeder	Clamp spring	RESSORT POUR THERMOMETRE	Fermo	KLEMVEER V/THERMOMETER ST/SO	Muelle fijación	20
6	8 717 208 050 0	Thermometer	Thermometer	Thermomètre	Termometro	Thermometer	Termómetro	31
7	8 710 735 438 0	Ein-/Auslaufrohr Edelstahl, 1253mm	Inlet/Outlet tube	Tube d'arrivée/évacuation	Tubo della presa/ entrata	Inlet/Outlet tube	Pipa del producto/de salida	41
8	8 711 006 060 0	Stecker	Plug	Connecteur	Spina	STEKKER NTC-VOELER ST...1ESK 300/ST 75	Anection	16
9	8 714 500 034 0	Sensor WW-NTC mit Aderendhülse 6m	Temperature sensor 6mm	SONDE DE TEMPERATURE 6mm	Sensore termometrico 6mm	Temperatuurvoeler 6mm	Sensor de temperatura 6mm	34
10	8 714 606 021 0	Klemmfeder	Clamp spring	Ressort	Fermo	KLEMVEER NTC SK120/140/160-4ZB	Muelle de tecla	25
17	8 712 303 516 0	Isolierung	Insulation	Isolation	Isolamento	Isolatie	Aislamiento	23
	8 738 505 974 0	Ventil	Globe valve	Robinet	Valvola	AFSLUITKRAAN	Válvula de globo	26

For:

Ersatzteilliste  
Spare parts list  
Liste des pièces de rechange  
Lista parti di ricambio  
Onderdelenlijst  
Lista de repuestos

# ST120-1Z/C1S5800 - 7719002424

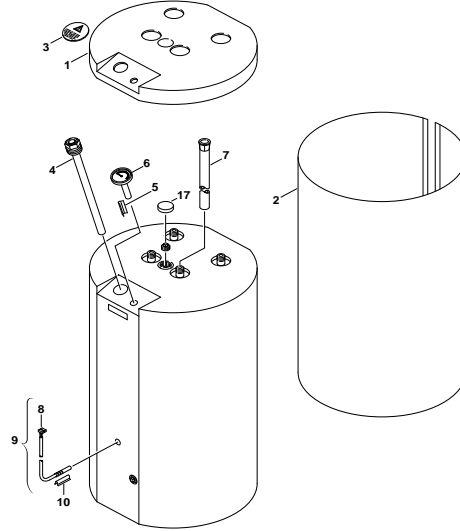

6720901191.AC/G

Pos	Bestell-Nr.	Bezeichnung	Description	Dénomination	Descrizione	Benaming	Descripción	PG
1	8 715 503 371 0	Haube hellgrau	Hood light grey	Carpot gris clair	Coperchio grigio chiaro	Deksel lichtgrijs	Capota girar claro	42
2	8 715 401 361 0	Mantel	Shell	Habillage	Mantello	Mantel	Carcasa	48
3	8 715 503 372 0	Abdeckung hellgrau	Covering sheet light grey	Couvercle gris clair	Coperchio grigio chiaro	Afdichting lichtgrijs	Chapa de protección girar claro	30
4	8 709 918 638 0	Anode 1"	Anode 1"	Anode 1"	Anodo 1"	ANODE SK 120/140/160-4ZB	Anodo 1"	37
5	8 714 606 024 0	Klemmfeder	Clamp spring	RESSORT POUR THERMOMETRE	Fermo	KLEMVEER V/THERMOMETER ST/SO	Muelle fijación	20
6	8 717 208 050 0	Thermometer	Thermometer	Thermomètre	Termometro	Thermometer	Termómetro	31
7	8 710 735 438 0	Ein-/Auslaufrohr Edelstahl, 1253mm	Inlet/Outlet tube	Tube d'arrivée/évacuation	Tubo della presa/ entrata	Inlet/Outlet tube	Pipa del producto/de salida	41
8	8 711 006 060 0	Stecker	Plug	Connecteur	Spina	STEKKER NTC-VOELER ST.-1ESK 300/ST 75	Aneccion	16
9	8 714 500 034 0	Sensor WW-NTC mit Aderendhülse 6m	Temperature sensor 6mm	SONDE DE TEMPERATURE 6mm	Sensore termometrico 6mm	Temperatuurvoeler 6mm	Sensor de temperatura 6mm	34
10	8 714 606 021 0	Klemmfeder	Clamp spring	Ressort	Fermo	KLEMVEER NTC SK120/140/160-4ZB	Muelle de tecla	25
17	8 712 303 516 0	Isolierung	Insulation	Isolation	Isolamento	Isolatie	Aislamiento	23
	8 738 505 974 0	Ventil	Globe valve	Robinet	Valvola	AFSLUITKRAAN	Válvula de globo	26

For:

Ersatzteilliste  
 Spare parts list  
 Liste des pièces de rechange  
 Lista parti di ricambio  
 Onderdelenlijst  
 Lista de repuestos

## ST120-2E - 7719003066

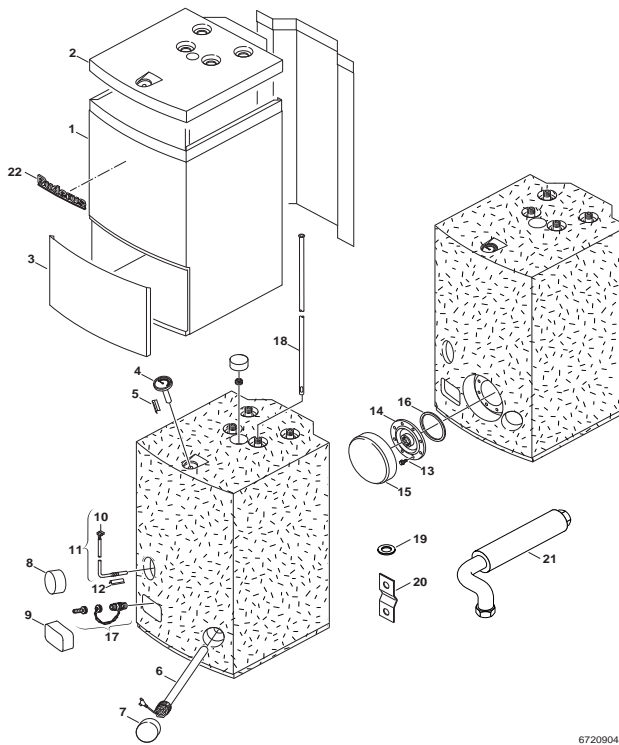

6720904582.aa.R

Pos	Bestell-Nr.	Bezeichnung	Description	Dénomination	Descrizione	Benaming	Descripción	PG
1	8 718 007 493 0	Mantel	Front shell	Habillage	Mantello	Mantel	Carcasa	49
2	8 715 503 570 0	Haube	Hood	Capot	Carpot	DEKSEL ST 120-2 E & EB	Capota	41
3	8 715 503 572 0	Abdeckung	Cover	Couvercle	Coperchio	Afdichting	Chapa de protección	34
4	8 717 208 111 0	Thermometer	Thermometer	Thermomètre	Termometro	THERMOMETER ST 120/160-2E-2EB	Termómetro	30
5	8 714 606 024 0	Klemmfeder	Clamp spring	RESSORT POUR THERMOMETRE	Fermo	KLEMVEER V/THERMOMETER ST/SO	Muelle fijación	20
6	8 718 505 052 0	Anode isoliert, 480mm	Anode 480mm	Anode 480mm	Anodo 480mm	Anode 480mm	Anodo 480mm	41
7	8 710 402 029 0	Kappe	panel	Capot de protection	Tappo	beschermkapje	tapa	20
8	8 710 402 029 0	Kappe	panel	Capot de protection	Tappo	beschermkapje	tapa	20
9	8 710 402 031 0	Isolierung	Insulation	Isolation	Isolamento	Isolatie	Aislamiento	15
10	8 711 006 060 0	Stecker	Plug	Connecteur	Spina	STEEKER NTC-VOELER ST.-1/ESK 300/ST 75	Anection	16
11	8 714 500 034 0	Sensor WW-NTC mit Aderendhülse 6m	Temperature sensor 6mm	SONDE DE TEMPERATURE 6mm	Sensore termometrico 6mm	Temperatuurvoeler 6mm	Sensor de temperatura 6mm	34
17	8 738 505 974 0	Ventil	Globe valve	Robinet	Valvola	AFSLUITKRAAN	Válvula de globo	26
18	8 710 735 457 0	Einlaufrohr Edelstahl 915lg.	Inlet tube stainless steel	Tube d'arrivée acier spécial	Tubo della presa acciaio raffinato	BUIS (INOX) INTERN BOILERS ST.-2E	Pipa del producto acero afinado	39
	8 711 301 131 0	Schelle	Clip	Support	Staffa	Klembeugel	Abrazadera	21
For:								

Ersatzteilliste  
 Spare parts list  
 Liste des pièces de rechange  
 Lista parti di ricambio  
 Onderdelenlijst  
 Lista de repuestos

**ST120-2E - 7719003068**

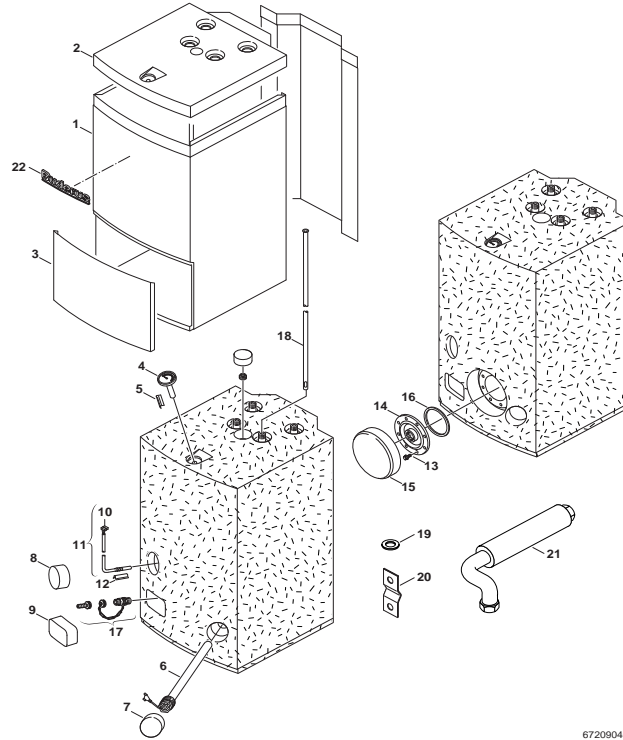

6720904582.aa.R

Pos	Bestell-Nr.	Bezeichnung	Description	Dénomination	Descrizione	Benaming	Descripción	PG
1	8 718 007 493 0	Mantel	Front shell	Habillage	Mantello	Mantel	Carcasa	49
2	8 715 503 570 0	Haube	Hood	Capot	Carpot	DEKSEL ST 120-2 E & EB	Capota	41
3	8 715 503 572 0	Abdeckung	Cover	Couvercle	Coperchio	Afdichting	Chapa de protección	34
4	8 717 208 111 0	Thermometer	Thermometer	Thermomètre	Termometro	THERMOMETER ST 120/160-2E-2EB	Termómetro	30
5	8 714 606 024 0	Klemmfeder	Clamp spring	RESSORT POUR THERMOMETRE	Fermo	KLEMVEER V/THERMOMETER ST/ISO	Muelle fijación	20
6	8 718 505 052 0	Anode isoliert, 480mm	Anode 480mm	Anode 480mm	Anodo 480mm	Anode 480mm	Anodo 480mm	41
7	8 710 402 029 0	Kappe	panel	Capot de protection	Tappo	beschermkapje	tapa	20
8	8 710 402 029 0	Kappe	panel	Capot de protection	Tappo	beschermkapje	tapa	20
9	8 710 402 031 0	Isolierung	Insulation	Isolation	Isolamento	Isolatie	Aislamiento	15
10	8 711 006 060 0	Stecker	Plug	Connecteur	Spina	STEKKER NTC-VOELER ST.-1/ESK 300/ST 75	Anection	16
11	8 714 500 034 0	Sensor WW-NTC mit Aderendhülse 6m	Temperature sensor 6mm	SONDE DE TEMPERATURE 6mm	Sensore termometrico 6mm	Temperatuurvoeler 6mm	Sensor de temperatura 6mm	34
17	8 738 505 974 0	Ventil	Globe valve	Robinet	Valvola	AFSLUITKRAAN	Válvula de globo	26
18	8 710 735 457 0	Einlaufrohr Edelstahl 915lg.	Inlet tube stainless steel	Tube d'arrivée acier spécial	Tubo della presa acciaio raffinato	BUIS (INOX) INTERN BOILERS ST.-2E	Pipa del producto acero afinado	39
	8 711 301 131 0	Schelle	Clip	Support	Staffa	Klembeugel	Abrazadera	21
For:								

Ersatzteilliste  
 Spare parts list  
 Liste des pièces de rechange  
 Lista parti di ricambio  
 Onderdelenlijst  
 Lista de repuestos

# ST120-2E - 7719003072

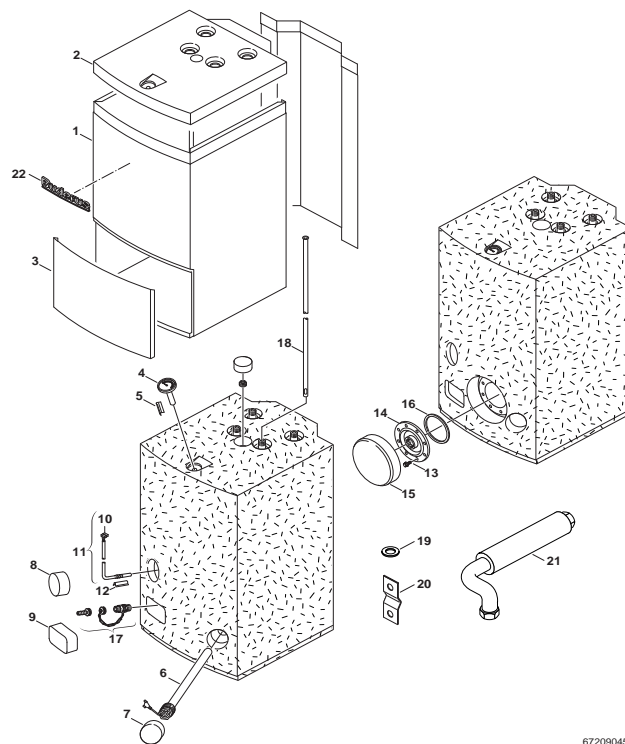

Pos	Bestell-Nr.	Bezeichnung	Description	Dénomination	Descrizione	Benaming	Descripción	PG
1	8 718 007 493 0	Mantel	Front shell	Habillage	Mantello	Mantel	Carcasa	49
2	8 715 503 570 0	Haube	Hood	Capot	Carpot	DEKSEL ST 120-2 E & EB	Capota	41
3	8 715 503 572 0	Abdeckung	Cover	Couvercle	Coperchio	Afdichting	Chapa de protección	34
4	8 717 208 111 0	Thermometer	Thermometer	Thermomètre	Termometro	THERMOMETER ST 120/160-2E-2EB	Termómetro	30
5	8 714 606 024 0	Klemmfeder	Clamp spring	RESSORT POUR THERMOMETRE	Fermo	KLEMVEER V/THERMOMETER ST/ISO	Muelle fijación	20
6	8 718 505 052 0	Anode isoliert, 480mm	Anode 480mm	Anode 480mm	Anodo 480mm	Anode 480mm	Anodo 480mm	41
7	8 710 402 029 0	Kappe	panel	Capot de protection	Tappo	beschermkapje	tapa	20
8	8 710 402 029 0	Kappe	panel	Capot de protection	Tappo	beschermkapje	tapa	20
9	8 710 402 031 0	Isolierung	Insulation	Isolation	Isolamento	Isolatie	Aislamiento	15
10	8 711 006 060 0	Stecker	Plug	Connecteur	Spina	STECKER NTC-VOELER ST...1E/SK 300/ST 75	Anection	16
11	8 714 500 034 0	Sensor WW-NTC mit Aderendhülse 6m	Temperature sensor 6mm	SONDE DE TEMPERATURE 6mm	Sensore termometrico 6mm	Temperatuurvoeler 6mm	Sensor de temperatura 6mm	34
17	8 738 505 974 0	Ventil	Globe valve	Robinet	Valvola	AFSLUITKRAAN	Válvula de globo	26
18	8 710 735 457 0	Einlaufrohr Edelstahl 915lg.	Inlet tube stainless steel	Tube d'arrivée acier spécial	Tubo della presa acciaio raffinato	BUIS (INOX) INTERN BOILERS ST...2E	Pipa del producto acero afinado	39
	8 711 301 131 0	Schelle	Clip	Support	Staffa	Klembeugel	Abrazadera	21

For:

Ersatzteilliste  
Spare parts list  
Liste des pièces de rechange  
Lista parti di ricambio  
Onderdelenlijst  
Lista de repuestos

# ST120-2E - 7719003243

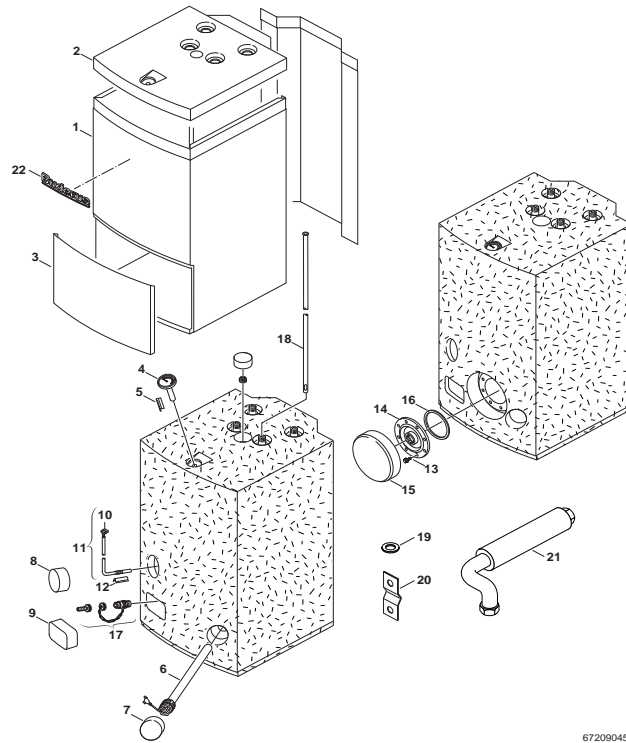

6720904582.aa.R

Pos	Bestell-Nr.	Bezeichnung	Description	Dénomination	Descrizione	Benaming	Descripción	PG
1	8 718 007 493 0	Mantel	Front shell	Habillage	Mantello	Mantel	Carcasa	49
2	8 715 503 570 0	Haube	Hood	Capot	Carpot	DEKSEL ST 120-2 E & EB	Capota	41
3	8 715 503 572 0	Abdeckung	Cover	Couvercle	Coperchio	Afdichting	Chapa de protección	34
4	8 717 208 111 0	Thermometer	Thermometer	Thermomètre	Termometro	THERMOMETER ST 120/160-2E-2EB	Termómetro	30
5	8 714 606 024 0	Klemmfeder	Clamp spring	RESSORT POUR THERMOMETRE	Fermo	KLEMVEER V/THERMOMETER ST/ISO	Muelle fijación	20
6	8 718 505 052 0	Anode isoliert, 480mm	Anode 480mm	Anode 480mm	Anodo 480mm	Anode 480mm	Anodo 480mm	41
7	8 710 402 029 0	Kappe	panel	Capot de protection	Tappo	beschermkapje	tapa	20
8	8 710 402 029 0	Kappe	panel	Capot de protection	Tappo	beschermkapje	tapa	20
9	8 710 402 031 0	Isolierung	Insulation	Isolation	Isolamento	Isolatie	Aislamiento	15
10	8 711 006 060 0	Stecker	Plug	Connecteur	Spina	STEKKER NTC-VOELER ST...1E/SK 300/ST 75	Aneccion	16
11	8 714 500 034 0	Sensor WW-NTC mit Aderendhülse 6m	Temperature sensor 6mm	SONDE DE TEMPERATURE 6mm	Sensore termometrico 6mm	Temperatuurvoeler 6mm	Sensor de temperatura 6mm	34
17	8 738 505 974 0	Ventil	Globe valve	Robinet	Valvola	AFSLUITKRAAN	Válvula de globo	26
18	8 710 735 457 0	Einlaufrohr Edelstahl 915lg.	Inlet tube stainless steel	Tube d'arrivée acier spécial	Tubo della presa acciaio raffinato	BUIS (INOX) INTERN BOILERS ST...2E	Pipa del producto acero afinado	39
	8 711 301 131 0	Schelle	Clip	Support	Staffa	Klembeugel	Abrazadera	21
For:								



**Ersatzteilliste**

Spare parts list

Liste des pièces de rechange

Lista parti di ricambio

Onderdelenlijst

Lista de repuestos

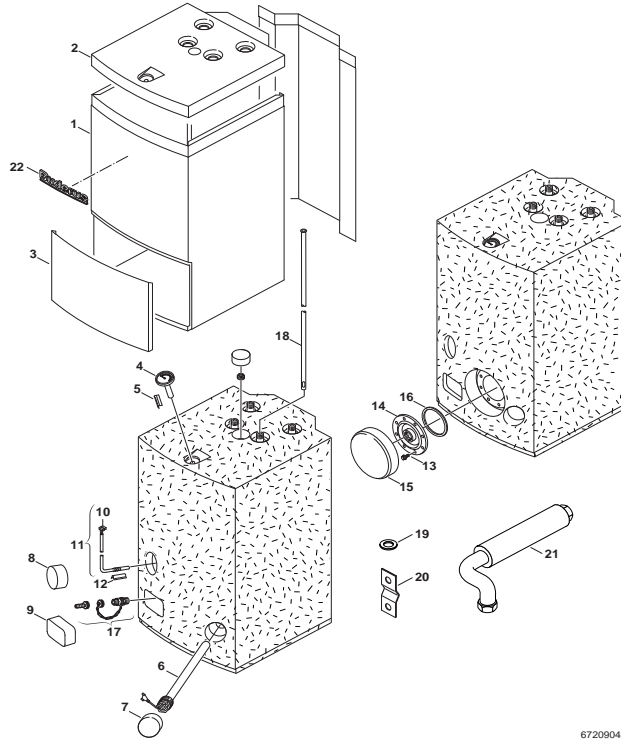
**ST120-2EB - 7719002885**

6720904582.aa.R

Pos	Bestell-Nr.	Bezeichnung	Description	Dénomination	Descrizione	Benaming	Descripción	PG
1	8 718 007 493 0	Mantel	Front shell	Habillage	Mantello	Mantel	Carcasa	49
2	8 715 503 570 0	Haube	Hood	Capot	Carpot	DEKSEL ST 120-2 E & EB	Capota	41
3	8 715 503 572 0	Abdeckung	Cover	Couvercle	Coperchio	Afdichting	Chapa de protección	34
4	8 717 208 111 0	Thermometer	Thermometer	Thermomètre	Termometro	THERMOMETER ST 120/160-2E-2EB	Termómetro	30
5	8 714 606 024 0	Klemmfeder	Clamp spring	RESSORT POUR THERMOMETRE	Fermo	KLEEMVEER V/THERMOMETR ST/ISO	Muelle fijación	20
6	8 718 505 052 0	Anode isoliert, 480mm	Anode 480mm	Anode 480mm	Anodo 480mm	Anode 480mm	Anodo 480mm	41
7	8 710 402 029 0	Kappe	panel	Capot de protection	Tappo	beschermkapje	tapa	20
8	8 710 402 029 0	Kappe	panel	Capot de protection	Tappo	beschermkapje	tapa	20
9	8 710 402 031 0	Isolierung	Insulation	Isolation	Isolamento	Isolatie	Aislamiento	15
10	8 711 006 060 0	Stecker	Plug	Connecteur	Spina	STEKKER NTC-VOELER ST...1E/ISK 300/ST 75	Aneccion	16
11	8 714 500 034 0	Sensor WW-NTC mit Aderendhülse 6m	Temperature sensor 6mm	SONDE DE TEMPERATURE 6mm	Sensore termometrico 6mm	Temperatuurvoeler 6mm	Sensor de temperatura 6mm	34
12	8 714 606 021 0	Klemmfeder	Clamp spring	Ressort	Fermo	KLEEMVEER NTC SK120/140/160-4ZB	Muelle de tecla	25
13	2 911 060 291 0	Schraube M10x25 (10x)	Screw M10x25 (10x)	Vis M10x25 (10x)	Vite M10x25 (10x)	Schroef M10x25 (10x)	Tornillo M10x25 (10x)	18
14	8 715 503 396 0	Flansch 1 1/2	Connecting flange 1 1/2	Trappe de visite 1 1/2	Flangia 1 1/2	Aansluitflens 1 1/2	Brida de conexión 1 1/2	40
15	8 718 006 674 0	Isolierung	Insulation	Isolation	Isolamento	Isolatie	Aislamiento	27
16	8 710 103 096 0	Dichtungs-Set 100x109D - 115/138Dx3 (1x)	Set of seals 100x109D - 115/138Dx3 (1x)	Jeu de joints 100x109D - 115/138Dx3 (1x)	Set guarnizioni 100x109D - 115/138Dx3	DICHTING FLENS SK...22B/3ZB (VANAF 070)	conjunto de juntas 100x109D - 115/138Dx3	23
17	8 738 505 974 0	Ventil	Globe valve	Robinet	Valvola	AFSLUITKRAAN	Válvula de globo	26
18	8 710 735 457 0	Einlaufrohr Edelstahl 915lg.	Inlet tube stainless steel	Tube d'arrivée acier spécial	Tube della presa acciaio raffinato	BUIS (INOX) INTERN BOILERS ST...2E	Pipa del producto acero afinado	39
	8 711 301 131 0	Schelle	Clip	Support	Staffa	Klembeugel	Abrazadera	21

For:



**Ersatzteilliste**

Spare parts list

Liste des pièces de rechange

Lista parti di ricambio

Onderdelenlijst

Lista de repuestos

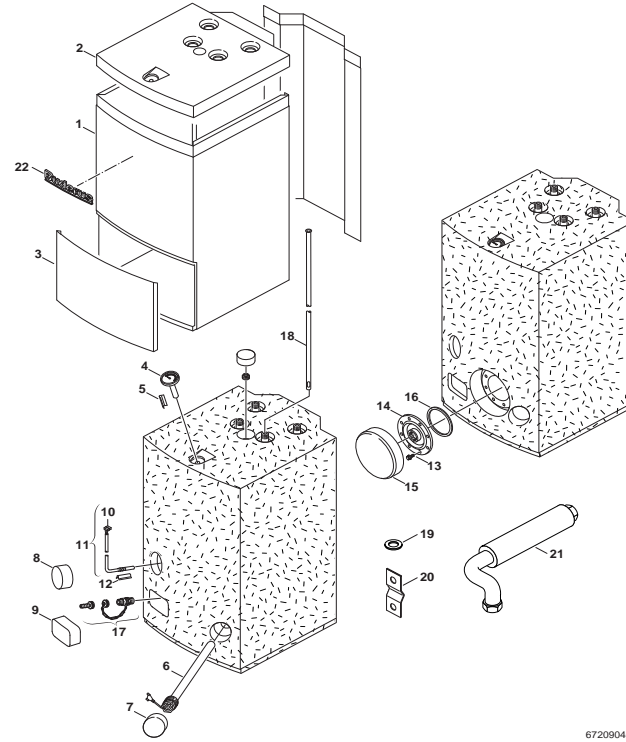
**ST120-2EB - 7719003269**

6720904582.aa.R

Pos	Bestell-Nr.	Bezeichnung	Description	Dénomination	Descrizione	Benaming	Descripción	PG
1	8 718 007 493 0	Mantel	Front shell	Habillage	Mantello	Mantel	Carcasa	49
2	8 715 503 570 0	Haube	Hood	Capot	Carpot	DEKSEL ST 120-2 E & EB	Capota	41
3	8 715 503 572 0	Abdeckung	Cover	Couvercle	Coperchio	Afdichting	Chapa de protección	34
4	8 717 208 111 0	Thermometer	Thermometer	Thermomètre	Termometro	THERMOMETER ST 120/160-2E-2EB	Termómetro	30
5	8 714 606 024 0	Klemmfeder	Clamp spring	RESSORT POUR THERMOMETRE	Fermo	KLEMVEER V/THERMOMETER ST/ISO	Muelle fijación	20
6	8 718 505 052 0	Anode isoliert, 480mm	Anode 480mm	Anode 480mm	Anodo 480mm	Anode 480mm	Anodo 480mm	41
7	8 710 402 029 0	Kappe	panel	Capot de protection	Tappo	beschermkapje	tapa	20
8	8 710 402 029 0	Kappe	panel	Capot de protection	Tappo	beschermkapje	tapa	20
9	8 710 402 031 0	Isolierung	Insulation	Isolation	Isolamento	Isolatie	Aislamiento	15
10	8 711 006 060 0	Stecker	Plug	Connecteur	Spina	STEKKER NTC-VOELER ST..1E/SK 300/ST 75	Anection	16
11	8 714 500 034 0	Sensor WW-NTC mit Aderendhülse 6m	Temperature sensor 6mm	SONDE DE TEMPERATURE 6mm	Sensore termometrico 6mm	Temperatuurvoeler 6mm	Sensor de temperatura 6mm	34
12	8 714 606 021 0	Klemmfeder	Clamp spring	Ressort	Fermo	KLEMVEER NTC SK120/140/160-4ZB	Muelle de tecla	25
13	2 911 060 291 0	Schraube M10x25 (10x)	Screw M10x25 (10x)	Vis M10x25 (10x)	Vite M10x25 (10x)	Schroef M10x25 (10x)	Tornillo M10x25 (10x)	18
14	8 715 503 396 0	Flansch 1 1/2	Connecting flange 1 1/2	Trappe de visite 1 1/2	Flangia 1 1/2	Aansluitflens 1 1/2	Brida de conexión 1 1/2	40
15	8 718 006 674 0	Isolierung	Insulation	Isolation	Isolamento	Isolatie	Aislamiento	27
16	8 710 103 096 0	Dichtungs-Set 100x109D - 115/138Dx3 (1x)	Set of seals 100x109D - 115/138Dx3 (1x)	Jeu de joints 100x109D - 115/138Dx3 (1x)	Set guarnizioni 100x109D - 115/138Dx3	DICHTING FLENS SK..22B/-3ZB (VANAF 070)	conjunto de juntas 100x109D - 115/138Dx3	23
17	8 738 505 974 0	Ventil	Globe valve	Robinet	Valvola	AFSLUITKRAAN	Válvula de globo	26
18	8 710 735 457 0	Einlaufrohr Edelstahl 915lg.	Inlet tube stainless steel	Tube d'arrivée acier spécial	Tubo della presa acciaio raffinato	BUIS (INOX) INTERN BOILERS ST..2E	Pipa del producto acero afinado	39
	8 701 103 134 0	Warenzeichen	Trade mark badge	Marquage	Targhetta	Fabrieksmerk	Marca	15
	8 711 301 131 0	Schelle	Clip	Support	Staffa	Klembeugel	Abrazadera	21

For:

**Ersatzteilliste**

Spare parts list

Liste des pièces de rechange

Lista parti di ricambio

Onderdelenlijst

Lista de repuestos

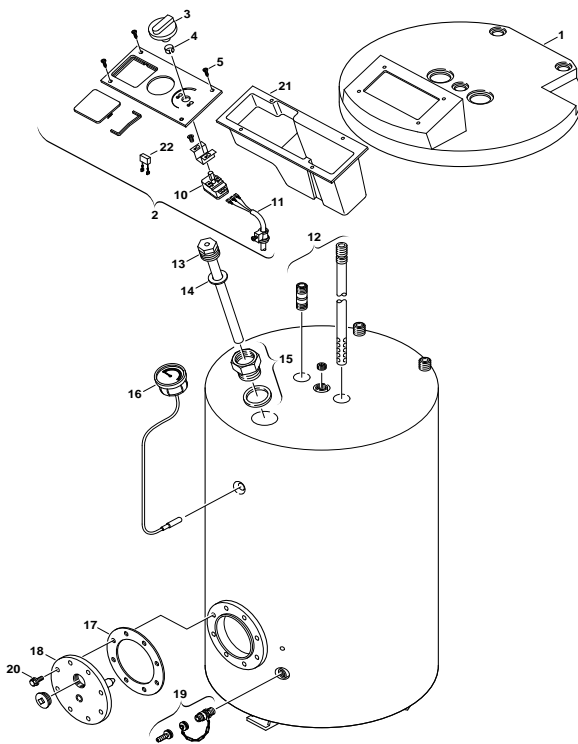
**ST120A - 7719000755**

6720901200.AC/G

Pos	Bestell-Nr.	Bezeichnung	Description	Dénomination	Descrizione	Benaming	Descripción	PG
1	<b>8 715 505 411 0</b>	Haube	Hood	Capot	Carpot	Deksel	Capota	36
2	<b>8 717 207 191 0</b>	Schalteinsatz	Insert of commutation	Insert de commutation	Quadro comandi	Schakelinzetstuk	Cuadro de mandos	50
3	<b>8 712 000 034 0</b>	Drehknopf	Rotary handle	Bouton de réglage	Manopola	Regelknop	Botón rotativo	12
4	<b>8 710 609 006 0</b>	Halter (10x)	Fixing bracket (10x)	Support (10x)	Angolare (10x)	Steunbeugel (10x)	Angulo soporte (10x)	12
5	<b>8 713 403 008 0</b>	Schraube (10x)	Screw	Vis (10x)	Vite (10x)	Schroef (10x)	Tornillo (10x)	11
10	<b>8 717 206 186 0</b>	Temperaturregler	Flow thermostat	Thermostat	Thermostat	<small>AQUASTAAT M WISSELKONTAKT SO 120-160-200</small>	Regulador de temperatura	36
11	<b>8 714 401 821 0</b>	Kabel	Cable	Faisceau	Cablaggio	Kabel	Cable	27
12	<b>8 710 735 438 0</b>	<small>Ein-/Auslaufrohr Edelstahl, 1253mm</small>	Inlet/Outlet tube	Tube d'arrivée/évacuation	Tube della presa/ entrata	Inlet/Outlet tube	Pipa del producto/de salida	41
13	<b>8 709 918 505 0</b>	Anode	Anode	Anode	Anodo	<small>ANODE SO 120-SK 130/2Z-ST 120</small>	Anodo	39
15	<b>8 709 918 657 0</b>	Gewindebuchse	Threaded bushing	Douille fileté	Boccola filettata	Draadbus	Casquillo roscado	17
16	<b>8 737 208 991 0</b>	Thermometer	Thermometer	Thermomètre	Termometro	<small>THERMOMETER SO...SK...ZZ-3Z - Z(W)...F</small>	Termómetro	37
19	<b>8 738 505 974 0</b>	Ventil	Globe valve	Robinet	Valvola	AFSLUITKRAAN	Válvula de globo	26
21	<b>8 715 503 119 0</b>	Abdeckung	Covering sheet	Couvercle	Coperchio	afdekkap, afdekking	Chapa de protección	33
22	<b>8 717 301 017 0</b>	Entstörkondensator	ENTSTÖRKONDENSATOR	Condensateur	Condensatore	<small>CONDENSATOR VOOR AQUASTAAT 8 717 206 974</small>	Condensador filtro	14

For:

Ersatzteilliste  
Spare parts list  
Liste des pièces de rechange  
Lista parti di ricambio  
Onderdelenlijst  
Lista de repuestos

# ST120B - 7719000775

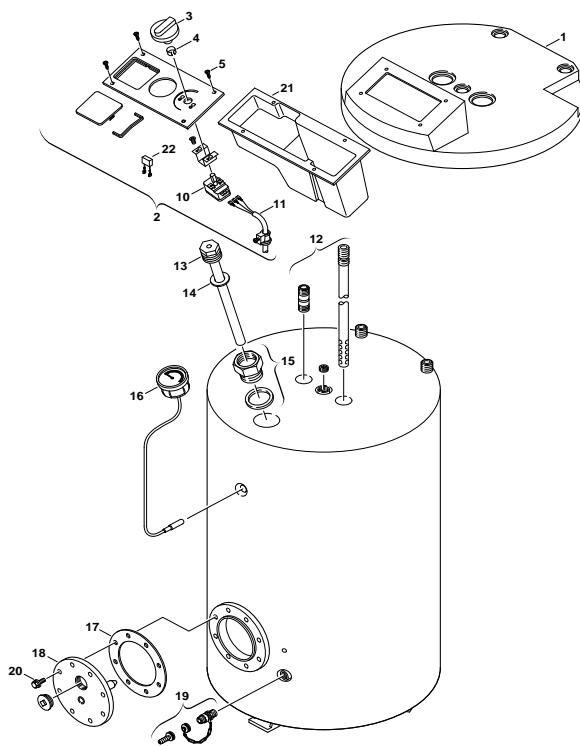

6720901200.AC/G

Pos	Bestell-Nr.	Bezeichnung	Description	Dénomination	Descrizione	Benaming	Descripción	PG
1	8 715 505 411 0	Haube	Hood	Capot	Carpot	Deksel	Capota	36
2	8 717 207 191 0	Schalteinsatz	Insert of commutation	Insert de commutation	Quadro comandi	Schakelinzetstuk	Cuadro de mandos	50
3	8 712 000 034 0	Drehknopf	Rotary handle	Bouton de réglage	Manopola	Regelknop	Botón rotativo	12
4	8 710 609 006 0	Halter (10x)	Fixing bracket (10x)	Support (10x)	Angolare (10x)	Steunbeugel (10x)	Angulo soporte (10x)	12
5	8 713 403 008 0	Schraube (10x)	Screw	Vis (10x)	Vite (10x)	Schroef (10x)	Tornillo (10x)	11
10	8 717 206 186 0	Temperaturregler	Flow thermostat	Thermostat	Thermostat	AQUASTAAT M/WISSELKONTAKT SO 120-160-200	Regulador de temperatura	36
11	8 714 401 821 0	Kabel	Cable	Faisceau	Cablaggio	Kabel	Cable	27
12	8 710 735 438 0	Ein-/Auslaufrohr Edelstahl, 1253mm	Inlet/Outlet tube	Tube d'arrivée/évacuation	Tubo della presa/ entrata	Inlet/Outlet tube	Pipa del producto/de salida	41
13	8 709 918 608 0	Anode	Anode	Anode	Anodo	Anode	Anodo	37
15	8 709 918 657 0	Gewindebuchse	Threaded bushing	Douille filetée	Boccola filettata	Draadbus	Casquillo roscado	17
16	8 737 208 991 0	Thermometer	Thermometer	Thermomètre	Termometro	THERMOMETER SO...SK...22-3Z - Z(W), F	Termómetro	37
17	8 710 103 096 0	Dichtungs-Set 100x109D - 115/138Dx3 (1x)	Set of seals 100x109D - 115/138Dx3 (1x)	Jeu de joints 100x109D - 115/138Dx3 (1x)	Set guarnizioni 100x109D - 115/138Dx3	DICHTING FLENS SK...22BI-3ZB (VANAF 070)	conjunto de juntas 100x109D - 115/138Dx3	23
18	8 715 503 241 0	Flanschdeckel	Flange cover	Couvercle de bride de racc.	Flangia bollitore	Flensdeksel	Tapa reborde	47
19	8 738 505 974 0	Ventil	Globe valve	Robinet	Valvola	AFSLUITKRAAN	Válvula de globo	26
20	2 911 060 342 0	Schraube M12x30 (10x)	Screw M12x30 (10x)	Vis M12x30 (10x)	Vite M12x30 (10x)	Schroef M12x30 (10x)	Tornillo M12x30 (10x)	16
21	8 715 503 119 0	Abdeckung	Covering sheet	Couvercle	Coperchio	afdekkap, afdekking	Chapa de protección	33
22	8 717 301 017 0	Entstörkondensator	ENTSTÖRKONDENSATOR	Condensateur	Condensatore	CONDENSATOR VOOR AQUASTAAT 8 737 206 974	Condensador filtro	14

For:

Ersatzteilliste  
Spare parts list  
Liste des pièces de rechange  
Lista parti di ricambio  
Onderdelenlijst  
Lista de repuestos

## ST120ES - 7719001979

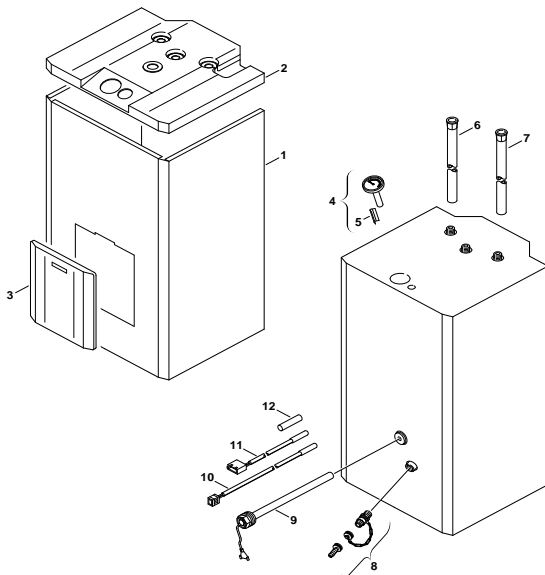

6720901199/G

Pos	Bestell-Nr.	Bezeichnung	Description	Dénomination	Descrizione	Benaming	Descripción	PG
1	8 715 401 293 0	Mantel weiß	Front shell white	Habillage blanc	Mantello bianco	Mantel wit	Carcasa blanco	53
2	8 715 503 362 0	Haube hellgrau	Hood light grey	Carpot gris clair	Coperchio grigio chiaro	Deksel lichtgrijs	Capota girar claro	42
3	8 715 503 397 0	Abdeckung hellgrau	Covering sheet light grey	Couvercle gris clair	Coperchio grigio chiaro	Afdichting lichtgrijs	Chapa de protección girar claro	41
4	8 717 208 050 0	Thermometer	Thermometer	Thermomètre	Termometro	Thermometer	Termómetro	31
5	8 714 606 024 0	Klemmfeder	Clamp spring	RESSORT POUR THERMOMETRE	Fermo	KLEEMVEER V/THERMOMETER ST/SO	Muelle fijación	20
6	8 710 735 187 0	Auslaufrohr Edelstahl 120mm	Outlet tube stainless steel 120mm	Tube de sortie acier spécial 120mm	Tubo di uscita in acciaio 120mm	Stalen uitloopbuisje 120mm	Tubo de salida del producto acero afinar	36
7	8 710 735 442 0	Einlaufrohr Edelstahl 850mm	Inlet tube stainless steel 850mm	Tube d'arrivée acier spécial 850mm	Tubo della presa acciaio raffinato 850mm	BUIS 850 MM INTERNE BOILERS (INOX)	Pipa del producto acero afinado 850mm	38
8	8 738 505 974 0	Ventil	Globe valve	Robinet	Valvola	AFLUITKRAAN	Válvula de globo	26
9	8 718 505 037 0	Anode	Anode	Anode	Anodo	Anode	Anodo	34
10	8 714 500 088 0	Temperaturfühler NTC1	Temperature sensor NTC1	Sonde de temperature CTN1	Sensore termometrico NTC1	Temperatuurvoeler NTC1	Sensor de temperatura NTC1	34
11	8 714 500 090 0	Temperaturfühler NTC2	Temperature sensor NTC2	Sonde de temperature CTN2	Sensore termometrico NTC2	Temperatuurvoeler NTC2	Sensor de temperatura NTC2	39
12	8 740 703 047 0	Silikonschlauch 250mm	Silicon hose 250mm	Tuyau de silicone 250mm	Tubo flessibile di silicone 250mm	SLANG ST 120/160 ES	Tubo flexible silicone 250mm	24

For:

Ersatzteilliste  
Spare parts list  
Liste des pièces de rechange  
Lista parti di ricambio  
Onderdelenlijst  
Lista de repuestos

ST130-2E - 7719000772

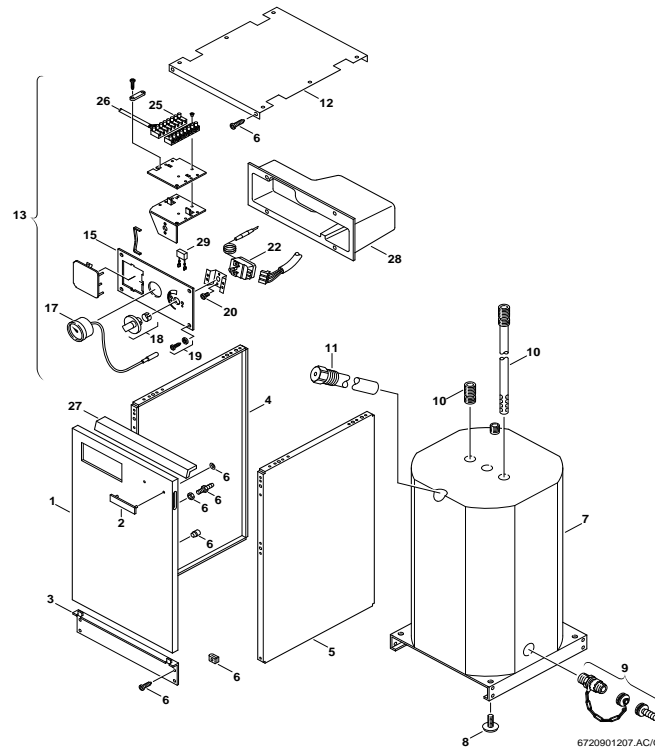

Pos	Bestell-Nr.	Bezeichnung	Description	Dénomination	Descrizione	Benaming	Descripción	PG
1	8 718 006 540 0	Tür	Door	Porte	Panello frontale	Deur	Puerta	48
2	8 701 103 029 0	Warenzeichen	Trade mark badge	Marquage	Targhetta	Fabrieksmerk	Marca	15
3	8 718 005 325 0	Blende	Shield	Cache	Mascherina	Paneel	Chapa cuadro	16
4	8 718 007 214 0	Seitenwand links	Side panel left	Côté gauche	Panello laterale sinistra	Zijpaneel links	Pared lateral a la izquierda	44
5	8 718 007 215 0	Seitenwand rechts	Side panel right	Côté droit	Panello laterale a destra	Zijpaneel rechts	Pared lateral a la derecha	44
6	8 719 918 771 0	Befestigungssatz	Fixing set	Joint de fixation	Set di fissaggio	Bevestigingsset	Juego piezas de fijacion	25
7	8 715 407 159 0	Behälter	Reservoir	Récipient	Sostegno	Reservoir	Déposito	74
8	8 713 401 069 0	Stellfuß	Foot	Pied	Vite	Voet	Pie	21
9	8 738 505 974 0	Ventil	Globe valve	Robinet	Valvola	AFSLUITKRAAN	Válvula de globo	26
10	8 710 735 438 0	Ein-/Auslaufrohr Edelstahl, 1253mm	Inlet/Outlet tube	Tube d'arrivée/évacuation	Tube della presa/ entrata	Inlet/Outlet tube	Pipa del producto/de salida	41
11	8 709 918 608 0	Anode	Anode	Anode	Anodo	Anode	Anodo	37
12	8 718 006 538 0	Deckel	Cover	Couvercle	Coperchio	Deksel	Tapa	40
13	8 717 207 191 0	Schalteinsatz	Insert of commutation	Insert de commutation	Quadro comandi	Schakelinzetstuk	Cuadro de mandos	50
15	8 715 506 392 0	Blende	Shield	Cache	Mascherina	Paneel	Chapa cuadro	32
17	8 737 208 991 0	Thermometer	Thermometer	Thermomètre	Termometro	THERMOMETER SO...-2Z-3Z - Z(W)... F	Termómetro	37
18	8 712 000 034 0	Drehknopf	Rotary handle	Bouton de réglage	Manopola	Regelknop	Botón rotativo	12
19	8 713 403 008 0	Schraube (10x)	Screw	Vis (10x)	Vite (10x)	Schroef (10x)	Tornillo (10x)	11
22	8 737 206 974 0	Temperaturregler	Flow thermostat	Thermostat	Thermostat	AQUASTAAT MWISSELKONTAKT *** 8717206188	Regulador de temperatura	36
26	8 714 401 821 0	Kabel	Cable	Faisceau	Cablaggio	Kabel	Cable	27
27	8 718 006 539 0	Winkel	Angle bracket	Equerre	Staffa	Hoeksteun	Angulo	30
28	8 715 503 119 0	Abdeckung	Covering sheet	Couvercle	Coperchio	afdekkap, afdekking	Chapa de protección	33
29	8 717 301 017 0	Entstörkondensator	ENTSTÖRKONDENSATOR	Condensateur	Condensatore	CONDENSATOR VOOR AQUASTAAT 8 737 206 974	Condensador filtro	14

For:

Ersatzteilliste  
Spare parts list  
Liste des pièces de rechange  
Lista parti di ricambio  
Onderdelenlijst  
Lista de repuestos

# ST160-1E - 7719001313

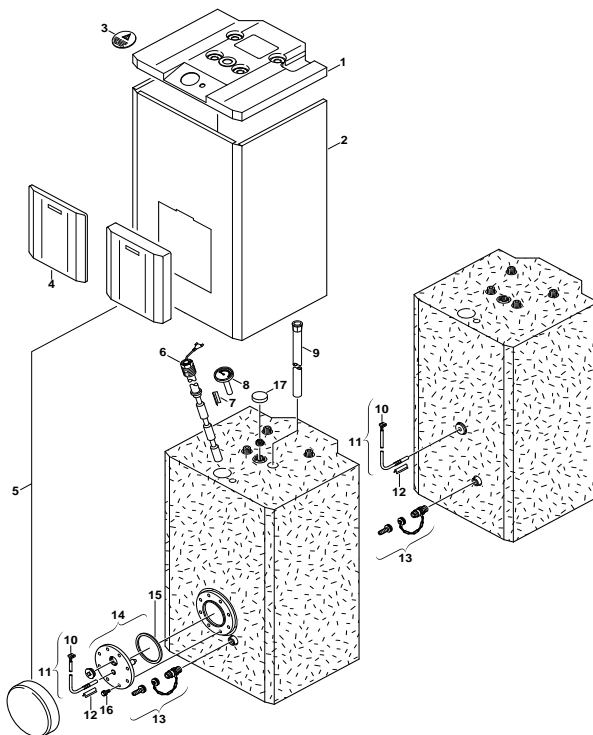

6720901198 AC/G

Pos	Bestell-Nr.	Bezeichnung	Description	Dénomination	Descrizione	Benaming	Descripción	PG
1	8 715 503 242 0	Haube grau	Hood grey	Capot gris	Carpot grigio	BOVENDEKSEL ST 160E	Capota girar	42
2	8 715 401 296 0	Mantel weiß	Front shell white	Habillage blanc	Mantello bianco	Mantel wit	Carcasa blanco	54
3	8 715 503 238 0	Abdeckung grau	Covering sheet grey	Couvercle gris	Coperchio grigio	ZELFKLEVER ST 120/160-1E	Chapa de protección girar	23
4	8 715 503 237 0	Abdeckung grau	Covering sheet grey	Couvercle gris	Coperchio grigio	Afdichting grijs	Chapa de protección girar	39
6	8 709 918 666 0	Anode 1"	Anode 1"	Anode 1"	Anodo 1"	ANODE (KETTING) ST120/160-1E /SK 130-3Z	Anodo 1"	43
7	8 714 606 024 0	Klemmfeder	Clamp spring	RESSORT POUR THERMOMETRE	Fermo	KLEMVEER W/THERMOMETER ST/SO	Muelle fijación	20
8	8 717 208 050 0	Thermometer	Thermometer	Thermomètre	Termometro	Thermometer	Termómetro	31
9	8 710 735 442 0	Einlaufrohr Edelstahl 850mm	Inlet tube stainless steel 850mm	Tube d'arrivée acier spécial 850mm	Tubo della presa acciaio raffinato 850mm	BUIS 850 MM INTERNE BOILERS (INOX)	Pipa del producto acero afinado 850mm	38
10	8 711 006 060 0	Stecker	Plug	Connecteur	Spina	STEKKER NTC-VOELER ST...1E/SK 300/ST 75	Anection	16
11	8 714 500 034 0	Sensor WW-NTC mit Aderendhülse 6m	Temperature sensor 6mm	SONDE DE TEMPERATURE 6mm	Sensore termometrico 6mm	Temperatuurvoeler 6mm	Sensor de temperatura 6mm	34
12	8 714 606 021 0	Klemmfeder	Clamp spring	Ressort	Fermo	KLEMVEER NTC SK120/140/160-4ZB	Muelle de tecla	25
13	8 738 505 974 0	Ventil	Globe valve	Robinet	Valvola	AFSLUITKRAAN	Válvula de globo	26
17	8 715 503 239 0	Isolierung	Insulation	Bouchon	Isolamento	ISOLATIE SK 300-1 SOLAR (7719001929)	Aislamiento	23

For:

## Ersatzteilliste

Spare parts list

Liste des pièces de rechange

Lista parti di ricambio

Onderdelenlijst

Lista de repuestos

ST160-1E - 7719002873

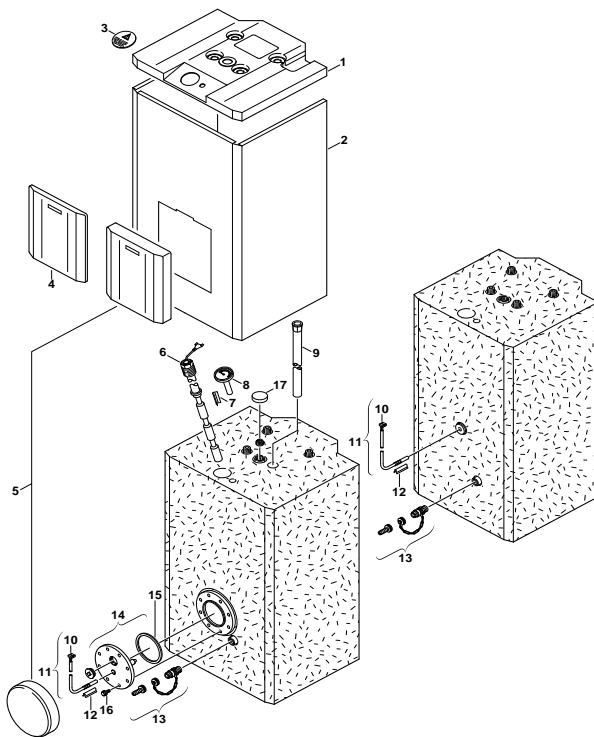

6720901198 AC/G

Pos	Bestell-Nr.	Bezeichnung	Description	Dénomination	Descrizione	Benaming	Descripción	PG
1	8 715 503 370 0	Haube hellgrau	Hood light grey	Carpot gris clair	Coperchio grigio chiaro	Deksel lichtgrijs	Capota girar claro	42
2	8 715 401 296 0	Mantel weiß	Front shell white	Habillage blanc	Mantello bianco	Mantel wit	Carcasa blanco	54
3	8 715 503 372 0	Abdeckung hellgrau	Covering sheet light grey	Couvercle gris clair	Coperchio grigio chiaro	Afdichting lichtgrijs	Chapa de protección girar claro	30
4	8 715 503 397 0	Abdeckung hellgrau	Covering sheet light grey	Couvercle gris clair	Coperchio grigio chiaro	Afdichting lichtgrijs	Chapa de protección girar claro	41
6	8 709 918 666 0	Anode 1"	Anode 1"	Anode 1"	Anodo 1"	ANODE (KETTING) ST120/160-1E /SK 130-3Z	Anodo 1"	43
7	8 714 606 024 0	Klemmfeder	Clamp spring	RESSORT POUR THERMOMETRE	Fermo	KLEMVEER V/THERMOMETER ST/SO	Muelle fijación	20
8	8 717 208 050 0	Thermometer	Thermometer	Thermomètre	Termometro	Thermometer	Termómetro	31
9	8 710 735 442 0	Einlaufrohr Edelstahl 850mm	Inlet tube stainless steel 850mm	Tube d'arrivée acier spécial 850mm	Tubo della presa acciaio raffinato 850mm	BUIS 850 MM INTERNE BOILERS (INOX)	Pipa del producto acero afinado 850mm	38
10	8 711 006 060 0	Stecker	Plug	Connecteur	Spina	STEKKER NTC-VOELER ST.-1E/SK 300/ST 75	Anection	16
11	8 714 500 034 0	Sensor WW-NTC mit Aderendhülse 6m	Temperature sensor 6mm	SONDE DE TEMPERATURE 6mm	Sensore termometrico 6mm	Temperatuurvoeler 6mm	Sensor de temperatura 6mm	34
12	8 714 606 021 0	Klemmfeder	Clamp spring	Ressort	Fermo	KLEMVEER NTC SK120/140/160-4ZB	Muelle de tecla	25
13	8 738 505 974 0	Ventil	Globe valve	Robinet	Valvola	AFSLUITKRAAN	Válvula de globo	26
17	8 715 503 239 0	Isolierung	Insulation	Bouchon	Isolamento	ISOLATIE SK 300-1 SOLAR (7719001929)	Aislamiento	23

For:

**Ersatzteilliste**

Spare parts list

Liste des pièces de rechange

Lista parti di ricambio

Onderdelenlijst

Lista de repuestos

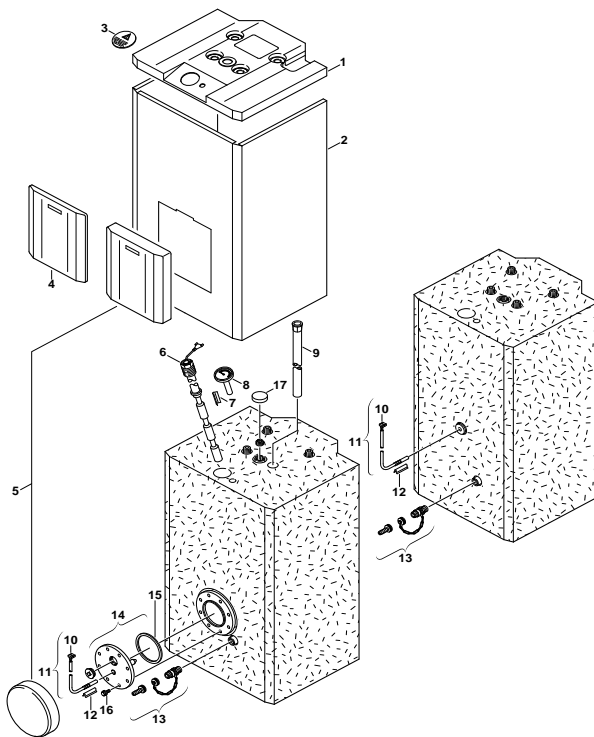
**ST160-1E S5300 - 7719001819**

6720901198 AC/G

Pos	Bestell-Nr.	Bezeichnung	Description	Dénomination	Descrizione	Benaming	Descripción	PG
1	8 715 503 370 0	Haube hellgrau	Hood light grey	Carpot gris clair	Coperchio grigio chiaro	Deksel lichtgrijs	Capota girar claro	42
2	8 715 401 296 0	Mantel weiß	Front shell white	Habillage blanc	Mantello bianco	Mantel wit	Carcasa blanco	54
3	8 715 503 372 0	Abdeckung hellgrau	Covering sheet light grey	Couvercle gris clair	Coperchio grigio chiaro	Afdichting lichtgrijs	Chapa de protección girar claro	30
4	8 715 503 397 0	Abdeckung hellgrau	Covering sheet light grey	Couvercle gris clair	Coperchio grigio chiaro	Afdichting lichtgrijs	Chapa de protección girar claro	41
6	8 709 918 666 0	Anode 1"	Anode 1"	Anode 1"	Anodo 1"	ANODE (KETTING) ST120/160-1E /SK 130-3Z	Anodo 1"	43
7	8 714 606 024 0	Klemmfeder	Clamp spring	RESSORT POUR THERMOMETRE	Fermo	KLEM/VEER V/THERMOMETER ST/SO	Muelle fijación	20
8	8 717 208 050 0	Thermometer	Thermometer	Thermomètre	Termometro	Thermometer	Termómetro	31
9	8 710 735 442 0	Einlaufrohr Edelstahl 850mm	Inlet tube stainless steel 850mm	Tube d'arrivée acier spécial 850mm	Tubo della presa acciaio raffinato 850mm	BUIS 850 MM INTERNE BOILERS (INOX)	Pipa del producto acero afinado 850mm	38
10	8 711 006 060 0	Stecker	Plug	Connecteur	Spina	STEKKER NTC-VOELER ST.-1E/SK 300/ST 75	Anection	16
11	8 714 500 034 0	Sensor WW-NTC mit Aderendhülse 6m	Temperature sensor 6mm	SONDE DE TEMPERATURE 6mm	Sensore termometrico 6mm	Temperatuurvoeler 6mm	Sensor de temperatura 6mm	34
12	8 714 606 021 0	Klemmfeder	Clamp spring	Ressort	Fermo	KLEM/VEER NTC SK120/140/160-4ZB	Muelle de tecla	25
13	8 738 505 974 0	Ventil	Globe valve	Robinet	Valvola	AFSLUITKRAAN	Válvula de globo	26
17	8 715 503 239 0	Isolierung	Insulation	Bouchon	Isolamento	ISOLATIE SK 300-1 SOLAR (7719001929)	Aislamiento	23
For:								



Ersatzteilliste  
 Spare parts list  
 Liste des pièces de rechange  
 Lista parti di ricambio  
 Onderdelenlijst  
 Lista de repuestos

## ST160-1E S5800 - 7719002449

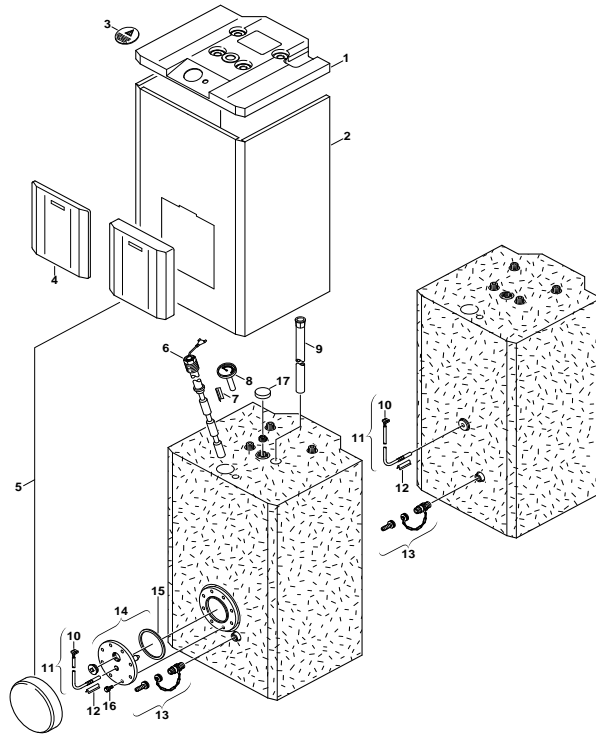

6720901198 AC/G

Pos	Bestell-Nr.	Bezeichnung	Description	Dénomination	Descrizione	Benaming	Descripción	PG
1	8 715 503 370 0	Haube hellgrau	Hood light grey	Carpot gris clair	Coperchio grigio chiaro	Deksel lichtgrijs	Capota girar claro	42
2	8 715 401 296 0	Mantel weiß	Front shell white	Habillage blanc	Mantello bianco	Mantel wit	Carcasa blanco	54
3	8 715 503 372 0	Abdeckung hellgrau	Covering sheet light grey	Couvercle gris clair	Coperchio grigio chiaro	Afdichting lichtgrijs	Chapa de protección girar claro	30
4	8 715 503 397 0	Abdeckung hellgrau	Covering sheet light grey	Couvercle gris clair	Coperchio grigio chiaro	Afdichting lichtgrijs	Chapa de protección girar claro	41
6	8 709 918 666 0	Anode 1"	Anode 1"	Anode 1"	Anodo 1"	ANODE (KETTING) ST120/160-1E /SK 130-3Z	Anodo 1"	43
7	8 714 606 024 0	Klemmfeder	Clamp spring	RESSORT POUR THERMOMETRE	Fermo	KLEMVEER V/THERMOMETER ST/SO	Muelle fijación	20
8	8 717 208 050 0	Thermometer	Thermometer	Thermomètre	Termometro	Thermometer	Termómetro	31
9	8 710 735 442 0	Einlaufrohr Edelstahl 850mm	Inlet tube stainless steel 850mm	Tube d'arrivée acier spécial 850mm	Tubo della presa acciaio raffinato 850mm	BUIS 850 MM INTERNE BOILERS (INOX)	Pipa del producto acero afinado 850mm	38
10	8 711 006 060 0	Stecker	Plug	Connecteur	Spina	STEKKER NTC-VOELER ST...1E/SK 300/ST 75	Anection	16
11	8 714 500 034 0	Sensor WW-NTC mit Aderendhülse 6m	Temperature sensor 6mm	SONDE DE TEMPERATURE 6mm	Sensore termometrico 6mm	Temperatuurvoeler 6mm	Sensor de temperatura 6mm	34
12	8 714 606 021 0	Klemmfeder	Clamp spring	Ressort	Fermo	KLEMVEER NTC SK120/140/160-4ZB	Muelle de tecla	25
13	8 738 505 974 0	Ventil	Globe valve	Robinet	Valvola	AFSLUITKRAAN	Válvula de globo	26
17	8 715 503 239 0	Isolierung	Insulation	Bouchon	Isolamento	ISOLATIE SK 300-1 SOLAR (7719001929)	Aislamiento	23
For:								

Ersatzteilliste  
Spare parts list  
Liste des pièces de rechange  
Lista parti di ricambio  
Onderdelenlijst  
Lista de repuestos

## ST160-1EB - 7719001314

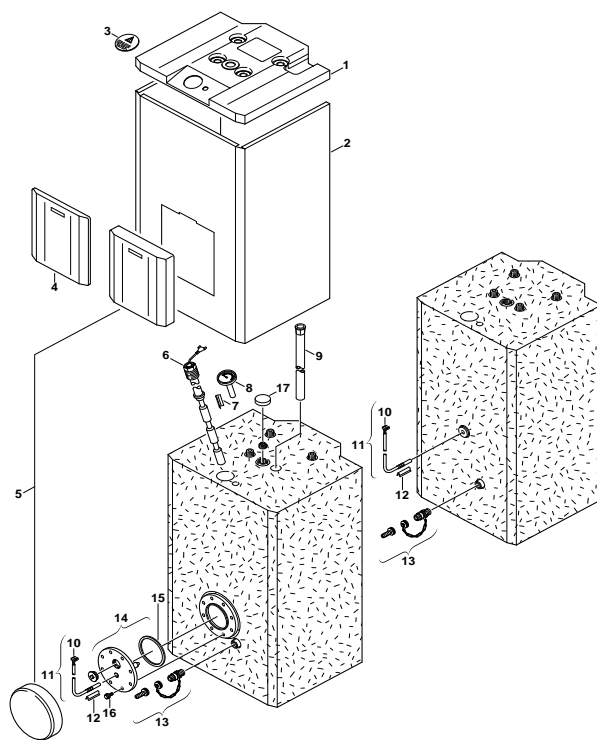

6720901198 AC/G

Pos	Bestell-Nr.	Bezeichnung	Description	Dénomination	Descrizione	Benaming	Descripción	PG
1	8 715 503 242 0	Haube grau	Hood grey	Capot gris	Carpot grigio	BOVENDEKSEL ST 160E	Capota girar	42
2	8 715 401 295 0	Mantel weiß	Front shell white	Habillage blanc	Mantello bianco	Mantel wit	C carcasa blanco	54
3	8 715 503 238 0	Abdeckung grau	Covering sheet grey	Couvercle gris	Coperchio grigio	ZELFKLEVER ST 120/160-1E	Chapa de protección girar	23
5	8 715 503 240 0	Abdeckung grau	Covering sheet grey	Couvercle gris	Coperchio grigio	Afdichting grijs	Chapa de protección girar	39
6	8 709 918 666 0	Anode 1"	Anode 1"	Anode 1"	Anodo 1"	ANODE (KETTING) ST120/160-1E /SK 130-3Z	Anodo 1"	43
7	8 714 606 024 0	Klemmfeder	Clamp spring	RESSORT POUR THERMOMETRE	Fermo	KLEMVEER W/THERMOMETER ST/SO	Muelle fijación	20
8	8 717 208 050 0	Thermometer	Thermometer	Thermomètre	Termometro	Thermometer	Termómetro	31
9	8 710 735 442 0	Einlaufrohr Edelstahl 850mm	Inlet tube stainless steel 850mm	Tube d'arrivée acier spécial 850mm	Tubo della presa acciaio raffinato 850mm	BUIS 850 MM INTERNE BOILERS (INOX)	Pipa del producto acero afinado 850mm	38
10	8 711 006 060 0	Stecker	Plug	Connecteur	Spina	STEKKER NTC-VOELER ST...1E/SK 300/ST 75	Aneccion	16
11	8 714 500 034 0	Sensor WW-NTC mit Aderendhülse 6m	Temperature sensor 6mm	SONDE DE TEMPERATURE 6mm	Sensore termometrico 6mm	Temperatuurvoeler 6mm	Sensor de temperatura 6mm	34
12	8 714 606 021 0	Klemmfeder	Clamp spring	Ressort	Fermo	KLEMVEER NTC SK120/140/160-4ZB	Muelle de tecla	25
13	8 738 505 974 0	Ventil	Globe valve	Robinet	Valvola	AFSLUITKRAAN	Válvula de globo	26
14	8 715 503 241 0	Flanschdeckel	Flange cover	Couvercle de bride de racc.	Flangia bollitore	Flensdeksel	Tapa reborde	47
15	8 710 103 096 0	Dichtungs-Set 100x109D - 115/138Dx3 (1x)	Set of seals 100x109D - 115/138Dx3 (1x)	Jeu de joints 100x109D - 115/138Dx3 (1x)	Set guarnizioni 100x109D - 115/138Dx3	DICHTING FLENS SK...2ZB/-3ZB (VANA F 070)	conjunto de juntas 100x109D - 115/138Dx3	23
16	2 911 060 291 0	Schraube M10x25 (10x)	Screw M10x25 (10x)	Vis M10x25 (10x)	Vite M10x25 (10x)	Schroef M10x25 (10x)	Tornillo M10x25 (10x)	18
16	2 911 060 342 0	Schraube M12x30 (10x)	Screw M12x30 (10x)	Vis M12x30 (10x)	Vite M12x30 (10x)	Schroef M12x30 (10x)	Tornillo M12x30 (10x)	16

For:

Ersatzteilliste  
Spare parts list  
Liste des pièces de rechange  
Lista parti di ricambio  
Onderdelenlijst  
Lista de repuestos

ST160-1EB/C1 - 7719002097

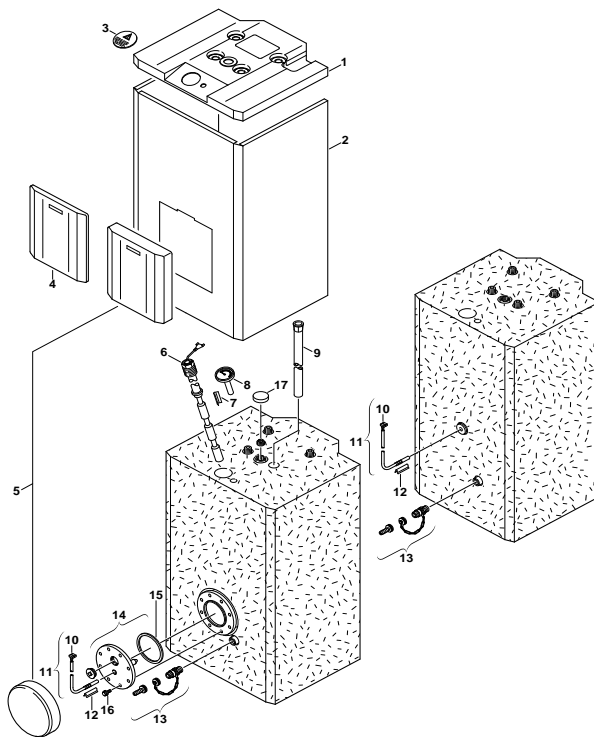

6720901198 AC/G

Pos	Bestell-Nr.	Bezeichnung	Description	Dénomination	Descrizione	Benaming	Descripción	PG
1	8 715 503 370 0	Haube hellgrau	Hood light grey	Carpot gris clair	Coperchio grigio chiaro	Deksel lichtgrijs	Capota girar claro	42
2	8 715 401 295 0	Mantel weiß	Front shell white	Habillage blanc	Mantello bianco	Mantel wit	Carcasa blanco	54
3	8 715 503 372 0	Abdeckung hellgrau	Covering sheet light grey	Couvercle gris clair	Coperchio grigio chiaro	Afdichting lichtgrijs	Chapa de protección girar claro	30
5	8 715 503 368 0	Abdeckung hellgrau	Covering sheet light grey	Couvercle gris clair	Coperchio grigio chiaro	Afdichting lichtgrijs	Chapa de protección girar claro	39
6	8 709 918 666 0	Anode 1"	Anode 1"	Anode 1"	Anodo 1"	ANODE (KETTING) ST120/160-1E /SK 130-3Z	Anodo 1"	43
7	8 714 606 024 0	Klemmfeder	Clamp spring	RESSORT POUR THERMOMETRE	Fermo	KLEMVEER V/THERMOMETER ST/SO	Muelle fijación	20
8	8 717 208 050 0	Thermometer	Thermometer	Thermomètre	Termometro	Thermometer	Termómetro	31
9	8 710 735 442 0	Einlaufrohr Edelstahl 850mm	Inlet tube stainless steel 850mm	Tube d'arrivée acier spécial 850mm	Tubo della presa acciaio raffinato 850mm	BUIS 850 MM INTERNE BOILERS (INOX)	Pipa del producto acero afinado 850mm	38
10	8 711 006 060 0	Stecker	Plug	Connecteur	Spina	STEKKER NTC-VOELER ST...1E/SK 300/ST 75	Anection	16
11	8 714 500 034 0	Sensor WW-NTC mit Aderendhülse 6m	Temperature sensor 6mm	SONDE DE TEMPERATURE 6mm	Sensore termometrico 6mm	Temperatuurvoeler 6mm	Sensor de temperatura 6mm	34
12	8 714 606 021 0	Klemmfeder	Clamp spring	Ressort	Fermo	KLEMVEER NTC SK120/140/160-4ZB	Muelle de tecla	25
13	8 738 505 974 0	Ventil	Globe valve	Robinet	Valvola	AFSLUITKRAAN	Válvula de globo	26
14	8 715 503 241 0	Flanschdeckel	Flange cover	Couvercle de bride de racc.	Flangia bollitore	Flensdeksel	Tapa reborde	47
15	8 710 103 096 0	Dichtungs-Set 100x109D - 115/138Dx3 (1x)	Set of seals 100x109D - 115/138Dx3 (1x)	Jeu de joints 100x109D - 115/138Dx3 (1x)	Set guarnizioni 100x109D - 115/138Dx3	DICHTING FLENS SK...22B/-3ZB (VANA F 070)	conjunto de juntas 100x109D - 115/138Dx3	23
16	2 911 060 291 0	Schraube M10x25 (10x)	Screw M10x25 (10x)	Vis M10x25 (10x)	Vite M10x25 (10x)	Schroef M10x25 (10x)	Tornillo M10x25 (10x)	18
16	2 911 060 342 0	Schraube M12x30 (10x)	Screw M12x30 (10x)	Vis M12x30 (10x)	Vite M12x30 (10x)	Schroef M12x30 (10x)	Tornillo M12x30 (10x)	16
17	8 715 503 239 0	Isolierung	Insulation	Bouchon	Isolamento	ISOLATIE SK 300-1 SOLAR (7719001929)	Aislamiento	23

For:

**Ersatzteilliste**  
**Spare parts list**  
**Liste des pièces de rechange**  
**Lista parti di ricambio**  
**Onderdelenlijst**  
**Lista de repuestos**

**ST160-1EBS0400/C1 - 7719001577**

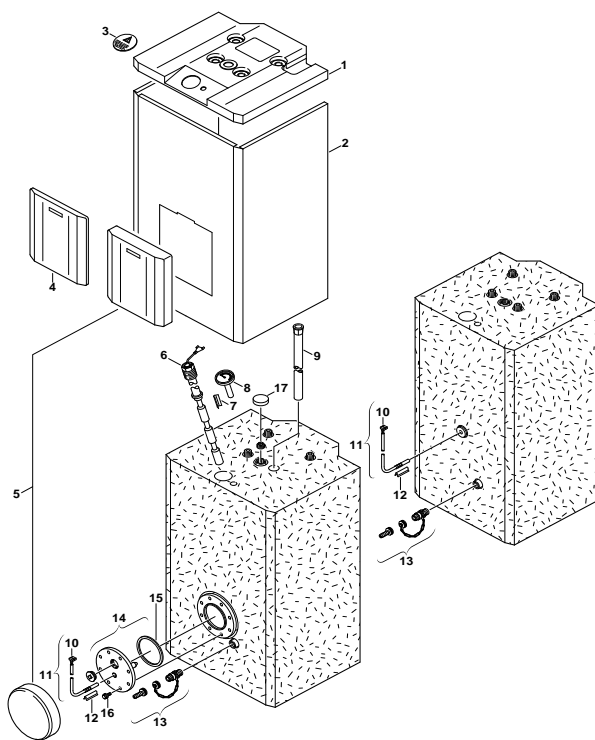

6720901198 AC/G

Pos	Bestell-Nr.	Bezeichnung	Description	Dénomination	Descrizione	Benaming	Descripción	PG
1	8 715 503 370 0	Haube hellgrau	Hood light grey	Carpot gris clair	Coperchio grigio chiaro	Deksel lichtgrijs	Capota girar claro	42
2	8 715 401 295 0	Mantel weiß	Front shell white	Habillage blanc	Mantello bianco	Mantel wit	Carcasa blanco	54
3	8 715 503 372 0	Abdeckung hellgrau	Covering sheet light grey	Couvercle gris clair	Coperchio grigio chiaro	Afdichting lichtgrijs	Chapa de protección girar claro	30
5	8 715 503 368 0	Abdeckung hellgrau	Covering sheet light grey	Couvercle gris clair	Coperchio grigio chiaro	Afdichting lichtgrijs	Chapa de protección girar claro	39
6	8 709 918 666 0	Anode 1"	Anode 1"	Anode 1"	Anodo 1"	ANODE (KETTING) ST120/160-1E /SK 130-3Z	Anodo 1"	43
7	8 714 606 024 0	Klemmfeder	Clamp spring	RESSORT POUR THERMOMETRE	Fermo	KLEMVEER V/THERMOMETER ST/ISO	Muelle fijación	20
8	8 717 208 050 0	Thermometer	Thermometer	Thermomètre	Termometro	Thermometer	Termómetro	31
9	8 710 735 442 0	Einlaufrohr Edelstahl 850mm	Inlet tube stainless steel 850mm	Tube d'arrivée acier spécial 850mm	Tubo della presa acciaio raffinato 850mm	BUIS 850 MM INTERNE BOILERS (INOX)	Pipa del producto acero afinado 850mm	38
10	8 711 006 060 0	Stecker	Plug	Connecteur	Spina	STEKKER NTC-VOELER ST...1E/SK 300/ST 75	Anection	16
11	8 714 500 034 0	Sensor WW-NTC mit Aderendhülse 6m	Temperature sensor 6mm	SONDE DE TEMPERATURE 6mm	Sensore termometrico 6mm	Temperatuurvoeler 6mm	Sensor de temperatura 6mm	34
12	8 714 606 021 0	Klemmfeder	Clamp spring	Ressort	Fermo	KLEMVEER NTC SK120/140/160-4ZB	Muelle de tecla	25
13	8 738 505 974 0	Ventil	Globe valve	Robinet	Valvola	AFSLUITKRAAN	Válvula de globo	26
14	8 715 503 241 0	Flanschdeckel	Flange cover	Couvercle de bride de racc.	Flangia bollitore	Flensdeksel	Tapa reborde	47
15	8 710 103 096 0	Dichtungs-Set 100x109D - 115/138Dx3 (1x)	Set of seals 100x109D - 115/138Dx3 (1x)	Jeu de joints 100x109D - 115/138Dx3 (1x)	Set guarnizioni 100x109D - 115/138Dx3	DICHTING FLENS SK...2ZB/3ZB (VANAF 070)	conjunto de juntas 100x109D - 115/138Dx3	23
16	2 911 060 291 0	Schraube M10x25 (10x)	Screw M10x25 (10x)	Vis M10x25 (10x)	Vite M10x25 (10x)	Schroef M10x25 (10x)	Tornillo M10x25 (10x)	18
16	2 911 060 342 0	Schraube M12x30 (10x)	Screw M12x30 (10x)	Vis M12x30 (10x)	Vite M12x30 (10x)	Schroef M12x30 (10x)	Tornillo M12x30 (10x)	16
17	8 715 503 239 0	Isolierung	Insulation	Bouchon	Isolamento	ISOLATIE SK 300-1 SOLAR (7719001929)	Aislamiento	23

For:

Ersatzteilliste  
Spare parts list  
Liste des pièces de rechange  
Lista parti di ricambio  
Onderdelenlijst  
Lista de repuestos

# ST160-1ES0200/C1 - 7719002094

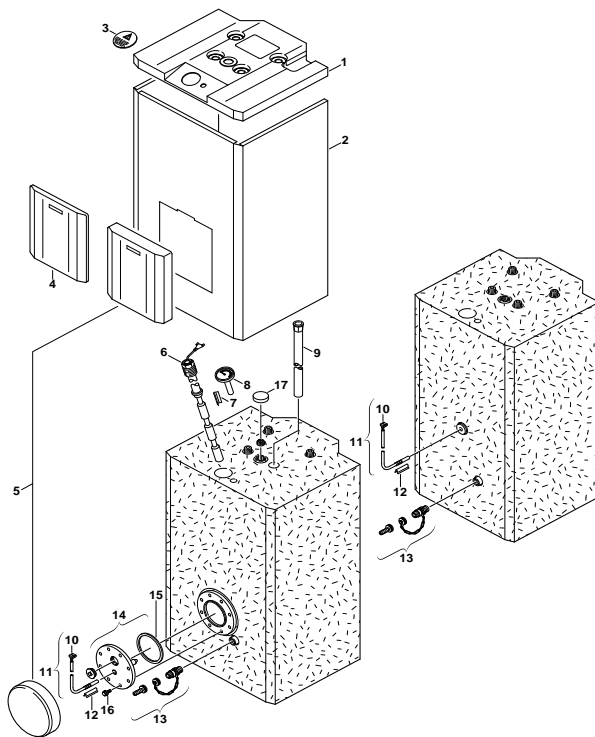

6720901198 AC/G

Pos	Bestell-Nr.	Bezeichnung	Description	Dénomination	Descrizione	Benaming	Descripción	PG
1	8 715 503 370 0	Haube hellgrau	Hood light grey	Carpot gris clair	Coperchio grigio chiaro	Deksel lichtgrijs	Capota girar claro	42
2	8 715 401 296 0	Mantel weiß	Front shell white	Habillage blanc	Mantello bianco	Mantel wit	Carcasa blanco	54
3	8 715 503 372 0	Abdeckung hellgrau	Covering sheet light grey	Couvercle gris clair	Coperchio grigio chiaro	Afdichting lichtgrijs	Chapa de protección girar claro	30
4	8 715 503 397 0	Abdeckung hellgrau	Covering sheet light grey	Couvercle gris clair	Coperchio grigio chiaro	Afdichting lichtgrijs	Chapa de protección girar claro	41
6	8 709 918 666 0	Anode 1"	Anode 1"	Anode 1"	Anodo 1"	ANODE (KETTING) ST120/160-1E /SK 130-3Z	Anodo 1"	43
7	8 714 606 024 0	Klemmfeder	Clamp spring	RESSORT POUR THERMOMETRE	Fermo	KLEM/VEER W/THERMOMETER ST/ISO	Muelle fijación	20
8	8 717 208 050 0	Thermometer	Thermometer	Thermomètre	Termometro	Thermometer	Termómetro	31
9	8 710 735 442 0	Einlaufrohr Edelstahl 850mm	Inlet tube stainless steel 850mm	Tube d'arrivée acier spécial 850mm	Tubo della presa acciaio raffinato 850mm	BUIS 850 MM INTERNE BOILERS (INOX)	Pipa del producto acero afinado 850mm	38
10	8 711 006 060 0	Stecker	Plug	Connecteur	Spina	STEKKER NTC-VOELER ST...1E/SK 300/ST 75	Anection	16
11	8 714 500 034 0	Sensor WW-NTC mit Aderendhülse 6m	Temperature sensor 6mm	SONDE DE TEMPERATURE 6mm	Sensore termometrico 6mm	Temperatuurvoeler 6mm	Sensor de temperatura 6mm	34
12	8 714 606 021 0	Klemmfeder	Clamp spring	Ressort	Fermo	KLEM/VEER NTC SK120/A40/160-4ZB	Muelle de tecla	25
13	8 738 505 974 0	Ventil	Globe valve	Robinet	Valvola	AFSLUITKRAAN	Válvula de globo	26
17	8 715 503 239 0	Isolierung	Insulation	Bouchon	Isolamento	ISOLATIE SK 300-1 SOLAR (7719001929)	Aislamiento	23

For:

Ersatzteilliste  
Spare parts list  
Liste des pièces de rechange  
Lista parti di ricambio  
Onderdelenlijst  
Lista de repuestos

**ST160-1ES3500/C1 - 7719001473**

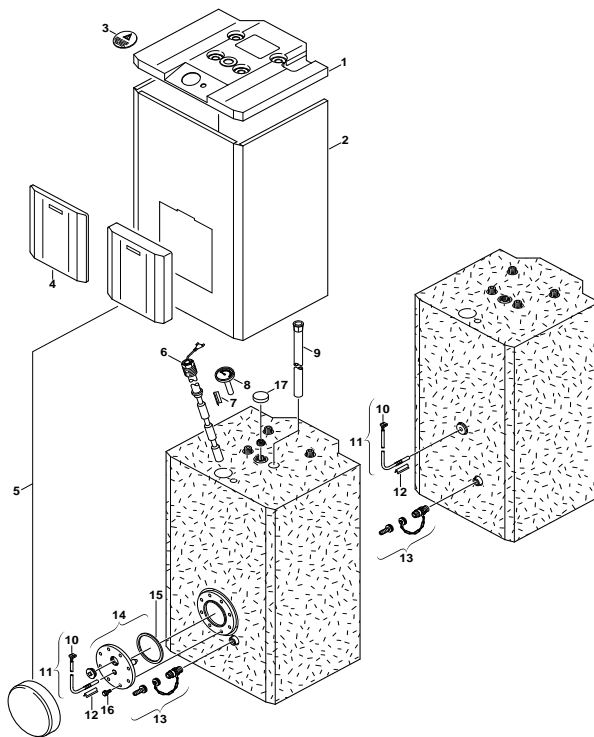

6720901198 AC/G

Pos	Bestell-Nr.	Bezeichnung	Description	Dénomination	Descrizione	Benaming	Descripción	PG
1	8 715 503 370 0	Haube hellgrau	Hood light grey	Carpot gris clair	Coperchio grigio chiaro	Deksel lichtgrijs	Capota girar claro	42
2	8 715 401 296 0	Mantel weiß	Front shell white	Habillage blanc	Mantello bianco	Mantel wit	Carcasa blanco	54
3	8 715 503 372 0	Abdeckung hellgrau	Covering sheet light grey	Couvercle gris clair	Coperchio grigio chiaro	Afdichting lichtgrijs	Chapa de protección girar claro	30
4	8 715 503 397 0	Abdeckung hellgrau	Covering sheet light grey	Couvercle gris clair	Coperchio grigio chiaro	Afdichting lichtgrijs	Chapa de protección girar claro	41
6	8 709 918 666 0	Anode 1"	Anode 1"	Anode 1"	Anodo 1"	ANODE (KETTING) ST120/160-1E /SK 130-3Z	Anodo 1"	43
7	8 714 606 024 0	Klemmfeder	Clamp spring	RESSORT POUR THERMOMETRE	Fermo	KLEMVEER V/THERMOMETER ST/ISO	Muelle fijación	20
8	8 717 208 050 0	Thermometer	Thermometer	Thermomètre	Termometro	Thermometer	Termómetro	31
9	8 710 735 442 0	Einlaufrohr Edelstahl 850mm	Inlet tube stainless steel 850mm	Tube d'arrivée acier spécial 850mm	Tubo della presa acciaio raffinato 850mm	BUIS 850 MM INTERNE BOILERS (INOX)	Pipa del producto acero afinado 850mm	38
10	8 711 006 060 0	Stecker	Plug	Connecteur	Spina	STEKKER NTC-VOELER ST.-1E/SK 300/ST 75	Anection	16
11	8 714 500 034 0	Sensor WW-NTC mit Aderendhülse 6m	Temperature sensor 6mm	SONDE DE TEMPERATURE 6mm	Sensore termometrico 6mm	Temperatuurvoeler 6mm	Sensor de temperatura 6mm	34
12	8 714 606 021 0	Klemmfeder	Clamp spring	Ressort	Fermo	KLEMVEER NTC SK120/140/160-4ZB	Muelle de tecla	25
13	8 738 505 974 0	Ventil	Globe valve	Robinet	Valvola	AFSLUITKRAAN	Válvula de globo	26
17	8 715 503 239 0	Isolierung	Insulation	Bouchon	Isolamento	ISOLATIE SK 300-1 SOLAR (7719001929)	Aislamiento	23
	7 709 500 048	Rückschlagventil 3/4"	Non-return valve 3/4"	Soupape de non-retour 3/4"	Valvola di non ritorno 3/4"	Terugslagklep 3/4"	válvula de retención 3/4"	
	7 709 500 052	Überdruckventil 1/2*3/4" 10 bar	VÁLVULA SEG. 1/2*3/4" 10 bar	VÁLVULA SEG. 1/2*3/4" 10 bar	Valvola di sovrappressione 1/2*3/4" 10 bar	Overdrukvelligheid 1/2*3/4" 10 bar	VÁLVULA SEG. 1/2*3/4" 10 bar	

For:

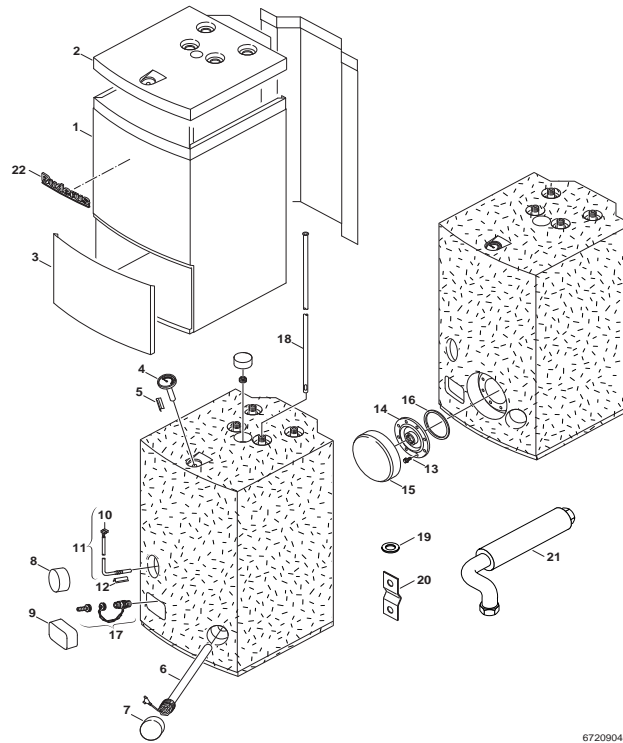
**Ersatzteilliste****Spare parts list****Liste des pièces de rechange****Lista parti di ricambio****Onderdelenlijst****Lista de repuestos****ST160-2E - 7719003067**

6720904582.aa.R

Pos	Bestell-Nr.	Bezeichnung	Description	Dénomination	Descrizione	Benaming	Descripción	PG
1	8 718 007 494 0	Mantel	Front shell	Habillage	Mantello	MANTEL VOOR ST 160-2EB "STORACELL"	Carcasa	50
2	8 715 503 571 0	Haube	Hood	Capot	Carpot	DEKSEL ST 160-2E	Capota	41
3	8 715 503 573 0	Abdeckung	Cover	Couvercle	Coperchio	Afdichting	Chapa de protección	35
4	8 717 208 111 0	Thermometer	Thermometer	Thermomètre	Termometro	THERMOMETER ST 120/160-2E-2EB	Termómetro	30
5	8 714 606 024 0	Klemmfeder	Clamp spring	RESSORT POUR THERMOMETRE	Fermo	KLEMVEER V/THERMOMETER ST/SO	Muelle fijación	20
6	8 718 505 052 0	Anode isoliert, 480mm	Anode 480mm	Anode 480mm	Anodo 480mm	Anode 480mm	Anodo 480mm	41
7	8 710 402 029 0	Kappe	panel	Capot de protection	Tappo	beschermkapje	tapa	20
8	8 710 402 029 0	Kappe	panel	Capot de protection	Tappo	beschermkapje	tapa	20
9	8 710 402 031 0	Isolierung	Insulation	Isolation	Isolamento	Isolatie	Aislamiento	15
10	8 711 006 060 0	Stecker	Plug	Connecteur	Spina	STEKKER NTC-VOELER ST...1E/SK 300/ST 75	Aneccion	16
11	8 714 500 034 0	Sensor WW-NTC mit Aderendhülse 6m	Temperature sensor 6mm	SONDE DE TEMPERATURE 6mm	Sensore termometrico 6mm	Temperatuurvoeler 6mm	Sensor de temperatura 6mm	34
17	8 738 505 974 0	Ventil	Globe valve	Robinet	Valvola	AFSLUITKRAAN	Válvula de globo	26
18	8 710 735 457 0	Einlaufrohr Edelstahl 915lg.	Inlet tube stainless steel	Tube d'arrivée acier spécial	Tubo della presa acciaio raffinato	BUIS (INOX) INTERN BOILERS ST...2E	Pipa del producto acero afinado	39
	8 711 301 131 0	Schelle	Clip	Support	Staffa	Klembeugel	Abrazadera	21
For:								

**Ersatzteilliste**
**Spare parts list**
**Liste des pièces de rechange**
**Lista parti di ricambio**
**Onderdelenlijst**
**Lista de repuestos**

# ST160-2E - 7719003069

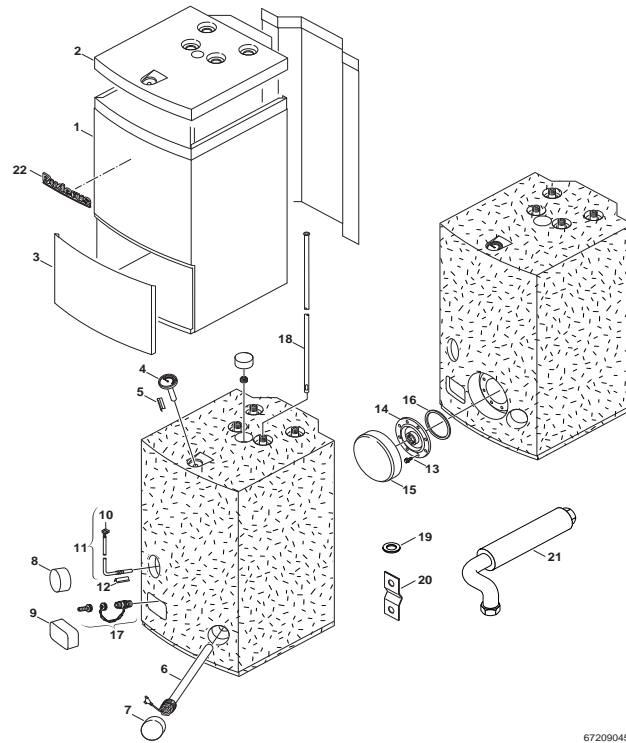

6720904582.aa.R

Pos	Bestell-Nr.	Bezeichnung	Description	Dénomination	Descrizione	Benaming	Descripción	PG
1	8 718 007 494 0	Mantel	Front shell	Habillage	Mantello	MANTEL VOOR ST 160-2EB "STORACELL"	Carcasa	50
2	8 715 503 571 0	Haube	Hood	Capot	Carpot	DEKSEL ST 160-2E	Capota	41
3	8 715 503 573 0	Abdeckung	Cover	Couvercle	Coperchio	Afdichting	Chapa de protección	35
4	8 717 208 111 0	Thermometer	Thermometer	Thermomètre	Termometro	THERMOMETER ST 120/160-2E-2EB	Termómetro	30
5	8 714 606 024 0	Klemmfeder	Clamp spring	RESSORT POUR THERMOMETRE	Fermo	KLEMVEER V/THERMOMETER ST/SO	Muelle fijación	20
6	8 718 505 052 0	Anode isoliert, 480mm	Anode 480mm	Anode 480mm	Anodo 480mm	Anode 480mm	Anodo 480mm	41
7	8 710 402 029 0	Kappe	panel	Capot de protection	Tappo	beschermkapje	tapa	20
8	8 710 402 029 0	Kappe	panel	Capot de protection	Tappo	beschermkapje	tapa	20
9	8 710 402 031 0	Isolierung	Insulation	Isolation	Isolamento	Isolatie	Aislamiento	15
10	8 711 006 060 0	Stecker	Plug	Connecteur	Spina	STEKKER NTC-VOELER ST...1E/SK 300/ST 75	Anection	16
11	8 714 500 034 0	Sensor WW-NTC mit Aderendhülse 6m	Temperature sensor 6mm	SONDE DE TEMPERATURE 6mm	Sensore termometrico 6mm	Temperatuurvoeler 6mm	Sensor de temperatura 6mm	34
17	8 738 505 974 0	Ventil	Globe valve	Robinet	Valvola	AFSLUITKRAAN	Válvula de globo	26
18	8 710 735 457 0	Einlaufrohr Edelstahl 915lg.	Inlet tube stainless steel	Tube d'arrivée acier spécial	Tubo della presa acciaio raffinato	BUIS (INOX) INTERN BOILERS ST...2E	Pipa del producto acero afinado	39
	8 711 301 131 0	Schelle	Clip	Support	Staffa	Klembeugel	Abrazadera	21

For:



**Ersatzteilliste**

Spare parts list

Liste des pièces de rechange

Lista parti di ricambio

Onderdelenlijst

Lista de repuestos

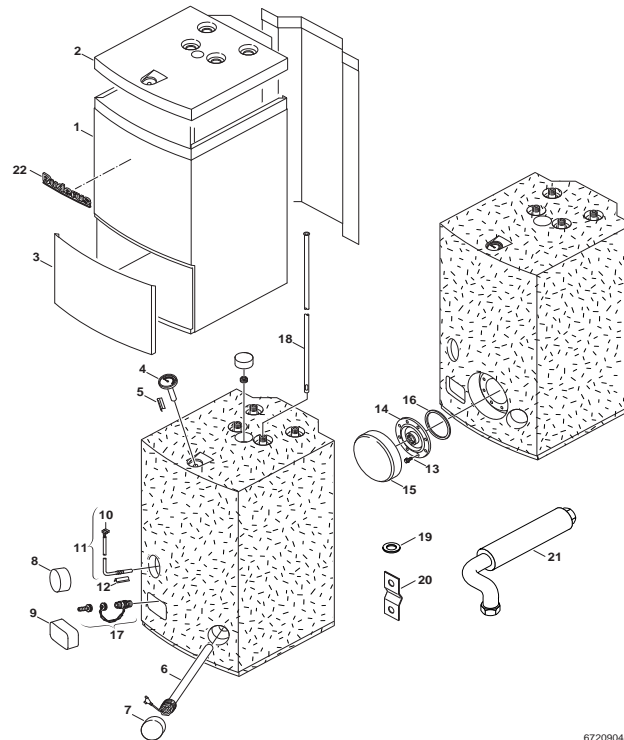
**ST160-2E - 7719003073**

6720904582.aa.R

Pos	Bestell-Nr.	Bezeichnung	Description	Dénomination	Descrizione	Benaming	Descripción	PG
1	8 718 007 494 0	Mantel	Front shell	Habillage	Mantello	MANTEL VOOR ST 160-2EB "STORACELL"	Carcasa	50
2	8 715 503 571 0	Haube	Hood	Capot	Carpot	DEKSEL ST 160-2E	Capota	41
3	8 715 503 573 0	Abdeckung	Cover	Couvercle	Coperchio	Afdichting	Chapa de protección	35
4	8 717 208 111 0	Thermometer	Thermometer	Thermomètre	Termometro	THERMOMETER ST 120/160-2E-2EB	Termómetro	30
5	8 714 606 024 0	Klemmfeder	Clamp spring	RESSORT POUR THERMOMETRE	Fermo	KLEMVEER V/THERMOMETER ST/ISO	Muelle fijación	20
6	8 718 505 052 0	Anode isoliert, 480mm	Anode 480mm	Anode 480mm	Anodo 480mm	Anode 480mm	Anodo 480mm	41
7	8 710 402 029 0	Kappe	panel	Capot de protection	Tappo	beschermkapje	tapa	20
8	8 710 402 029 0	Kappe	panel	Capot de protection	Tappo	beschermkapje	tapa	20
9	8 710 402 031 0	Isolierung	Insulation	Isolation	Isolamento	Isolatie	Aislamiento	15
10	8 711 006 060 0	Stecker	Plug	Connecteur	Spina	STEKKER NTC-VOELER ST...1ESK 300/ST 75	Anection	16
11	8 714 500 034 0	Sensor WW-NTC mit Aderendhülse 6m	Temperature sensor 6mm	SONDE DE TEMPERATURE 6mm	Sensore termometrico 6mm	Temperatuurvoeler 6mm	Sensor de temperatura 6mm	34
17	8 738 505 974 0	Ventil	Globe valve	Robinet	Valvola	AFSLUITKRAAN	Válvula de globo	26
18	8 710 735 457 0	Einlaufrohr Edelstahl 915lg.	Inlet tube stainless steel	Tube d'arrivée acier spécial	Tubo della presa acciaio raffinato	BUIS (INOX) INTERN BOILERS ST...2E	Pipa del producto acero afinado	39
	8 711 301 131 0	Schelle	Clip	Support	Staffa	Klembeugel	Abrazadera	21
For:								



Ersatzteilliste  
Spare parts list  
Liste des pièces de rechange  
Lista parti di ricambio  
Onderdelenlijst  
Lista de repuestos

**ST160-2EB - 7719002757**

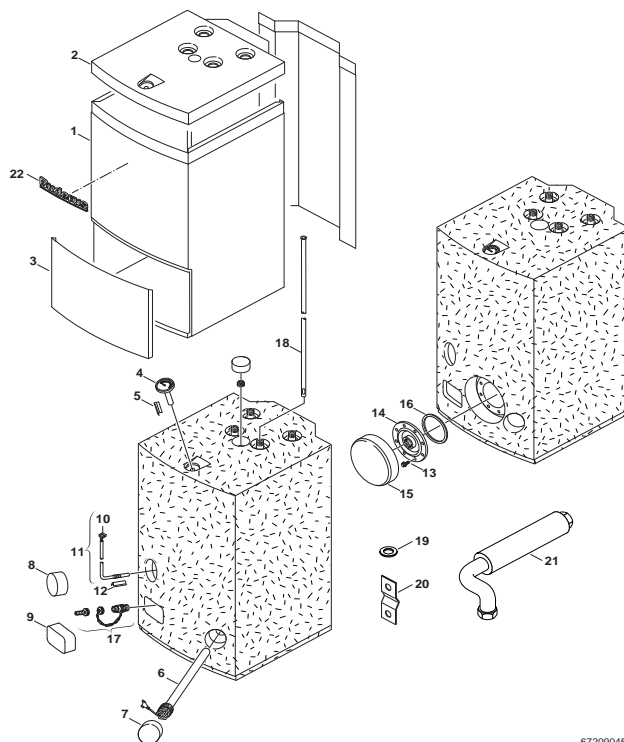

6720904582.aa.R

Pos	Bestell-Nr.	Bezeichnung	Description	Dénomination	Descrizione	Benaming	Descripción	PG
1	<b>8 718 007 494 0</b>	Mantel	Front shell	Habillage	Mantello	MANTEL VOOR ST 160-2EB "STORACELL"	Carcasa	50
2	<b>8 715 503 571 0</b>	Haube	Hood	Capot	Carpot	DEKSEL ST 160-2E	Capota	41
3	<b>8 715 503 573 0</b>	Abdeckung	Cover	Couvercle	Coperchio	Afdichting	Chapa de protección	35
4	<b>8 717 208 111 0</b>	Thermometer	Thermometer	Thermomètre	Termometro	THERMOMETER ST 120/160-2E-2EB	Termómetro	30
5	<b>8 714 606 024 0</b>	Klemmfeder	Clamp spring	RESSORT POUR THERMOMETRE	Fermo	KLEMVEER V/THERMOMETER ST/ISO	Muelle fijación	20
6	<b>8 718 505 052 0</b>	Anode isoliert, 480mm	Anode 480mm	Anode 480mm	Anodo 480mm	Anode 480mm	Anodo 480mm	41
7	<b>8 710 402 029 0</b>	Kappe	panel	Capot de protection	Tappo	beschermkapje	tapa	20
8	<b>8 710 402 029 0</b>	Kappe	panel	Capot de protection	Tappo	beschermkapje	tapa	20
9	<b>8 710 402 031 0</b>	Isolierung	Insulation	Isolation	Isolamento	Isolatie	Aislamiento	15
10	<b>8 711 006 060 0</b>	Stecker	Plug	Connecteur	Spina	STEKKER NTC-VOELER ST...1E/ISK 300/ST 75	Anection	16
11	<b>8 714 500 034 0</b>	Sensor WW-NTC mit Aderendhülse 6m	Temperature sensor 6mm	SONDE DE TEMPERATURE 6mm	Sensore termometrico 6mm	Temperatuurvoeler 6mm	Sensor de temperatura 6mm	34
13	<b>2 911 060 291 0</b>	Schraube M10x25 (10x)	Screw M10x25 (10x)	Vis M10x25 (10x)	Vite M10x25 (10x)	Schroef M10x25 (10x)	Tornillo M10x25 (10x)	18
14	<b>8 715 503 396 0</b>	Flansch 1 1/2	Connecting flange 1 1/2	Trappe de visite 1 1/2	Flangia 1 1/2	Aansluitflens 1 1/2	Brida de conexión 1 1/2	40
15	<b>8 718 006 674 0</b>	Isolierung	Insulation	Isolation	Isolamento	Isolatie	Aislamiento	27
16	<b>8 710 103 096 0</b>	Dichtungs-Set 100x109D - 115/138Dx3 (1x)	Set of seals 100x109D - 115/138Dx3 (1x)	Jeu de joints 100x109D - 115/138Dx3 (1x)	Set guarnizioni 100x109D - 115/138Dx3	DICHTING FLENS SK...22BI-3ZB (VANAF 0710	conjunto de juntas 100x109D - 115/138Dx3	23
17	<b>8 738 505 974 0</b>	Ventil	Globe valve	Robinet	Valvola	AFLSLUITKRAAN	Válvula de globo	26
18	<b>8 710 735 457 0</b>	Einlaufrohr Edelstahl 915lg.	Inlet tube stainless steel	Tube d'arrivée acier spécial	Tubo della presa acciaio raffinato	BUIS (INOX) INTERN BOILERS ST...2E	Pipa del producto acero afinado	39
	<b>8 711 301 131 0</b>	Schelle	Clip	Support	Staffa	Klembeugel	Abrazadera	21

For:

Ersatzteilliste  
 Spare parts list  
 Liste des pièces de rechange  
 Lista parti di ricambio  
 Onderdelenlijst  
 Lista de repuestos

# ST160-2EB - 7719002886

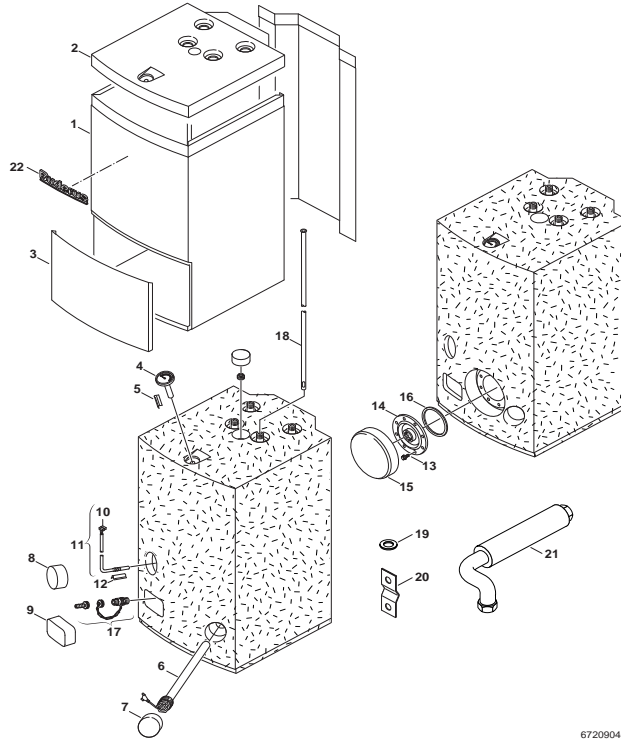

6720904582.aa.R

Pos	Bestell-Nr.	Bezeichnung	Description	Dénomination	Descrizione	Benaming	Descripción	PG
1	8 718 007 494 0	Mantel	Front shell	Habillage	Mantello	MANTEL VOOR ST 160-2EB "STORACELL"	Carcasa	50
2	8 715 503 571 0	Haube	Hood	Capot	Carpot	DEKSEL ST 160-2E	Capota	41
3	8 715 503 573 0	Abdeckung	Cover	Couvercle	Coperchio	Afdichting	Chapa de protección	35
4	8 717 208 111 0	Thermometer	Thermometer	Thermomètre	Termometro	THERMOMETER ST 120/160-2E-2EB	Termómetro	30
5	8 714 606 024 0	Klemmfeder	Clamp spring	RESSORT POUR THERMOMETRE	Fermo	KLEMVEER V/THERMOMETER ST/SO	Muelle fijación	20
6	8 718 505 052 0	Anode isoliert, 480mm	Anode 480mm	Anode 480mm	Anodo 480mm	Anode 480mm	Anodo 480mm	41
7	8 710 402 029 0	Kappe	panel	Capot de protection	Tappo	beschermkapje	tapa	20
8	8 710 402 029 0	Kappe	panel	Capot de protection	Tappo	beschermkapje	tapa	20
9	8 710 402 031 0	Isolierung	Insulation	Isolation	Isolamento	Isolatie	Aislamiento	15
10	8 711 006 060 0	Stecker	Plug	Connecteur	Spina	STEKKER NTC-VOELER ST...1E/SK 300/ST 75	Anection	16
11	8 714 500 034 0	Sensor WW-NTC mit Aderendhülse 6m	Temperature sensor 6mm	SONDE DE TEMPERATURE 6mm	Sensore termometrico 6mm	Temperatuurvoeler 6mm	Sensor de temperatura 6mm	34
13	2 911 060 291 0	Schraube M10x25 (10x)	Screw M10x25 (10x)	Vis M10x25 (10x)	Vite M10x25 (10x)	Schroef M10x25 (10x)	Tornillo M10x25 (10x)	18
14	8 715 503 396 0	Flansch 1 1/2	Connecting flange 1 1/2	Trappe de visite 1 1/2	Flangia 1 1/2	Aansluitflens 1 1/2	Brida de conexión 1 1/2	40
15	8 718 006 674 0	Isolierung	Insulation	Isolation	Isolamento	Isolatie	Aislamiento	27
16	8 710 103 096 0	Dichtungs-Set 100x109D - 115/138Dx3 (1x)	Set of seals 100x109D - 115/138Dx3 (1x)	Jeu de joints 100x109D - 115/138Dx3 (1x)	Set guarnizioni 100x109D - 115/138Dx3	DICHTING FLENS SK...22BI-32B (VANAF 0710	conjunto de juntas 100x109D - 115/138Dx3	23
17	8 738 505 974 0	Ventil	Globe valve	Robinet	Valvola	AFSLUITKRAAN	Válvula de globo	26
18	8 710 735 457 0	Einlaufrohr Edelstahl 915lg.	Inlet tube stainless steel	Tube d'arrivée acier spécial	Tubo della presa acciaio raffinato	BUIS (INOX) INTERN BOILERS ST...2E	Pipa del producto acero afinado	39
	8 711 301 131 0	Schelle	Clip	Support	Staffa	Klembeugel	Abrazadera	21

For:

Ersatzteilliste  
Spare parts list  
Liste des pièces de rechange  
Lista parti di ricambio  
Onderdelenlijst  
Lista de repuestos

**ST160-2EB - 7719003270**

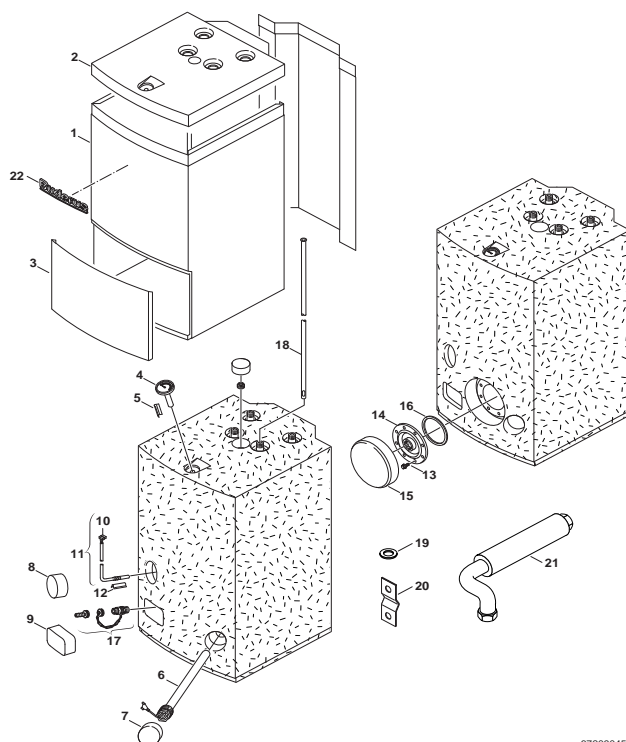

6720904582.aa.R

Pos	Bestell-Nr.	Bezeichnung	Description	Dénomination	Descrizione	Benaming	Descripción	PG
1	8 718 007 494 0	Mantel	Front shell	Habillage	Mantello	MANTEL VOOR ST 160-2EB "STORACELL"	Carcasa	50
2	8 715 503 571 0	Haube	Hood	Capot	Carpot	DEKSEL ST 160-2E	Capota	41
3	8 715 503 573 0	Abdeckung	Cover	Couvercle	Coperchio	Afdichting	Chapa de protección	35
4	8 717 208 111 0	Thermometer	Thermometer	Thermomètre	Termometro	THERMOMETER ST 120/160-2E-2EB	Termómetro	30
5	8 714 606 024 0	Klemmfeder	Clamp spring	RESSORT POUR THERMOMETRE	Fermo	KLEMVEER V/THERMOMETER ST/ISO	Muelle fijación	20
6	8 718 505 052 0	Anode isoliert, 480mm	Anode 480mm	Anode 480mm	Anodo 480mm	Anode 480mm	Anodo 480mm	41
7	8 710 402 029 0	Kappe	panel	Capot de protection	Tappo	beschermkapje	tapa	20
8	8 710 402 029 0	Kappe	panel	Capot de protection	Tappo	beschermkapje	tapa	20
9	8 710 402 031 0	Isolierung	Insulation	Isolation	Isolamento	Isolatie	Aislamiento	15
10	8 711 006 060 0	Stecker	Plug	Connecteur	Spina	STEKKER NTC-VOELER ST...1E/SK 300/ST 75	Anection	16
11	8 714 500 034 0	Sensor WW-NTC mit Aderendhülse 6m	Temperature sensor 6mm	SONDE DE TEMPERATURE 6mm	Sensore termometrico 6mm	Temperatuurvoeler 6mm	Sensor de temperatura 6mm	34
13	2 911 060 291 0	Schraube M10x25 (10x)	Screw M10x25 (10x)	Vis M10x25 (10x)	Vite M10x25 (10x)	Schroef M10x25 (10x)	Tornillo M10x25 (10x)	18
14	8 715 503 396 0	Flansch 1 1/2	Connecting flange 1 1/2	Trappe de visite 1 1/2	Flangia 1 1/2	Aansluitflens 1 1/2	Brida de conexión 1 1/2	40
15	8 718 006 674 0	Isolierung	Insulation	Isolation	Isolamento	Isolatie	Aislamiento	27
16	8 710 103 096 0	Dichtungs-Set 100x109D - 115/138Dx3 (1x)	Set of seals 100x109D - 115/138Dx3 (1x)	Jeu de joints 100x109D - 115/138Dx3 (1x)	Set guarnizioni 100x109D - 115/138Dx3	DICHTING FLENS SK...22BI-3ZB (VANAF 07/0)	conjunto de juntas 100x109D - 115/138Dx3	23
17	8 738 505 974 0	Ventil	Globe valve	Robinet	Valvola	AFSLUITKRAAN	Válvula de globo	26
18	8 710 735 457 0	Einlaufrohr Edelstahl 915lg.	Inlet tube stainless steel	Tube d'arrivée acier spécial	Tubo della presa acciaio raffinato	BUIS (INOX) INTERN BOILERS ST...2E	Pipa del producto acero afinado	39
	8 701 103 134 0	Warenzeichen	Trade mark badge	Marquage	Targhetta	Fabrieksmerk	Marca	15
	8 711 301 131 0	Schelle	Clip	Support	Staffa	Klembeugel	Abrazadera	21

For:

Ersatzteilliste  
Spare parts list  
Liste des pièces de rechange  
Lista parti di ricambio  
Onderdelenlijst  
Lista de repuestos

# ST160ES - 7719001980

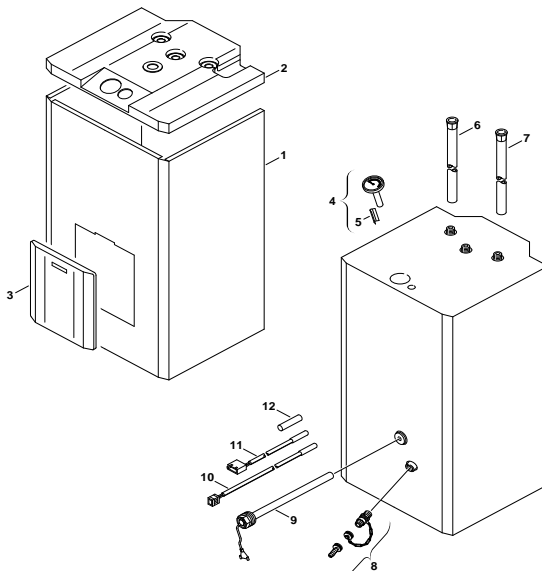

6720901199/G

Pos	Bestell-Nr.	Bezeichnung	Description	Dénomination	Descrizione	Benaming	Descripción	PG
1	8 715 401 296 0	Mantel weiß	Front shell white	Habillage blanc	Mantello bianco	Mantel wit	Carcasa blanco	54
2	8 715 503 363 0	Haube hellgrau	Hood light grey	Carpot gris clair	Coperchio grigio chiaro	DEKSEL ST 160 ES "STORAMAXX"	Capota girar claro	43
3	8 715 503 397 0	Abdeckung hellgrau	Covering sheet light grey	Couvercle gris clair	Coperchio grigio chiaro	Afdichting lichtgrijs	Chapa de protección girar claro	41
4	8 717 208 050 0	Thermometer	Thermometer	Thermomètre	Termometro	Thermometer	Termómetro	31
5	8 714 606 024 0	Klemmfeder	Clamp spring	RESSORT POUR THERMOMETRE	Fermo	KLEMVEER V/THERMOMETER ST/SO	Muelle fijación	20
6	8 710 735 187 0	Auslaufrohr Edelstahl 120mm	Outlet tube stainless steel 120mm	Tube de sortie acier spécial 120mm	Tubo di uscita in acciaio 120mm	Stalen uitloopbuisje 120mm	Tubo de salida del producto acero afinar	36
7	8 718 225 014 0	Rohr-Einlaufrohr 900mm	Pipe 900mm	Tube d'arrivée 900mm	Tubo della presa 900mm	Pijp 900mm	Pipa del producto 900mm	36
8	8 738 505 974 0	Ventil	Globe valve	Robinet	Valvola	AFSLUITKRAAN	Válvula de globo	26
9	8 718 505 037 0	Anode	Anode	Anode	Anodo	Anode	Anodo	34
10	8 714 500 088 0	Temperaturfühler NTC1	Temperature sensor NTC1	Sonde de temperature CTN1	Sensore termometrico NTC1	Temperatuurvoeler NTC1	Sensor de temperatura NTC1	34
11	8 714 500 090 0	Temperaturfühler NTC2	Temperature sensor NTC2	Sonde de temperature CTN2	Sensore termometrico NTC2	Temperatuurvoeler NTC2	Sensor de temperatura NTC2	39
12	8 740 703 047 0	Silikonschlauch 250mm	Silicon hose 250mm	Tuyau de silicone 250mm	Tubo flessibile di silicone 250mm	SLANG ST 120/160 ES	Tubo flexible silicone 250mm	24

For:

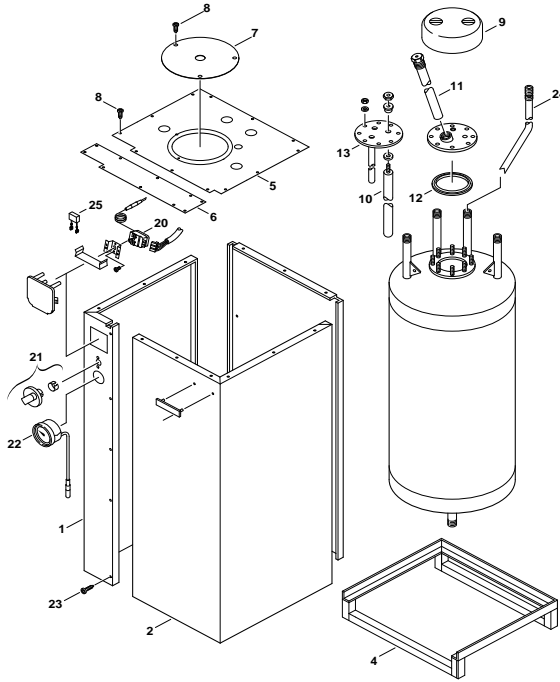
**Ersatzteilliste**
**Spare parts list**
**Liste des pièces de rechange**
**Lista parti di ricambio**
**Onderdelenlijst**
**Lista de repuestos**
**SU110E - 7719000856**

6720901204.AC/G

Pos	Bestell-Nr.	Bezeichnung	Description	Dénomination	Descrizione	Benaming	Descripción	PG
1	8 718 005 392 0	Seitenwand links	Side panel left	Côté gauche	Pannelo laterale sinistra	Zijpaneel links	Pared lateral a la izquierda	41
2	8 718 005 393 0	Seitenwand rechts	Side panel right	Côté droit	Pannelo laterale a destra	Zijpaneel rechts	Pared lateral a la derecha	42
4	8 709 918 660 0	Untergestell	Underframe	Chassis	Piastra di fissaggio	Chassis	Armaçon inferior	52
5	8 718 005 394 0	Deckel	Cover	Couvercle	Coperchio	Deksel	Tapa	33
6	8 718 005 395 0	Deckel	Cover	Couvercle	Coperchio	Deksel	Tapa	30
7	8 700 000 046 0	Abdeckung	Covering sheet	Couvercle	Coperchio	Afdichting	Chapa de protección	30
8	8 713 403 008 0	Schraube (10x)	Screw	Vis (10x)	Vite (10x)	Schroef (10x)	Tornillo (10x)	11
9	8 715 503 149 0	Abdeckung	Covering sheet	Couvercle	Coperchio	Afdichting	Chapa de protección	34
10	8 709 918 505 0	Anode	Anode	Anode	Anodo	ANODE SO 120-SK 130/22-ST 120	Anodo	39
10	8 719 918 767 0	Anode	Anode	Anode	Anodo	Anode	Anodo	41
12	8 710 103 512 0	Dichtung	Washer	Joint	Guarnizione	DICHTING ST 110-E	Junta	19
13	8 715 705 052 0	Flansch	Connecting flange	Bride de raccordement	Flangia	FLENS ST 110E	Brida de conexión	46
20	8 717 206 186 0	Temperaturregler	Flow thermostat	Thermostat	Thermostat	AQUASTAAT MWISSELKONTAKT SO 120-160-200	Regulador de temperatura	36
21	8 712 000 034 0	Drehknopf	Rotary handle	Bouton de réglage	Manopola	Regelknop	Botón rotativo	12
22	8 737 208 991 0	Thermometer	Thermometer	Thermomètre	Termometro	THERMOMETER SO...ZZ-3Z - Z(W)...F	Termómetro	37
23	2 910 614 431 0	Schraube 4,8X9,5 (10x)	Screw 4,8X9,5 (10x)	Vis 4,8X9,5 (10x)	Vite 4,8X9,5 (10x)	Schroef 4,8X9,5 (10x)	Tornillo 4,8X9,5 (10x)	11
24	8 710 715 466 0	Einlaufrohr	Inlet tube	Tube d'arrivée	Tubo della presa	Toevoerpijp	Pipa del producto	36
25	8 717 301 017 0	Entstörkondensator	ENTSTÖRKONDENSATOR	Condensateur	Condensatore	CONDENSATOR VOOR AQUASTAAT 8 737 206 974	Condensador filtro	14

For:

**Ersatzteilliste**

Spare parts list

Liste des pièces de rechange

Lista parti di ricambio

Onderdelenlijst

Lista de repuestos

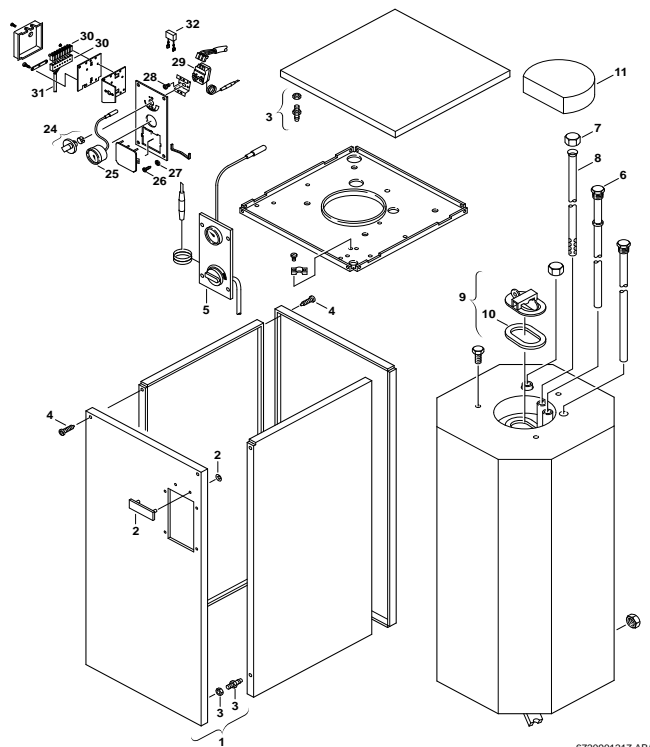
**SW300-1 - 7739100070**

6720901217.AB/G

Pos	Bestell-Nr.	Bezeichnung	Description	Dénomination	Descrizione	Benaming	Descripción	PG
1	8 735 402 977 0	Vorderwand	Cover	Couvercle	Coperchio	Voordeksel	Tapa	44
2	8 701 103 029 0	Warenzeichen	Trade mark badge	Marquage	Targhetta	Fabrieksmerk	Marca	15
3	8 719 918 772 0	Befestigungssatz	Fixing set	Joint de fixation	Set di fissaggio	Bevestigingsset	Juego piezas de fijacion	23
4	8 713 403 008 0	Schraube (10x)	Screw	Vis (10x)	Vite (10x)	Schroef (10x)	Tornillo (10x)	11
6	8 709 918 506 0	Anode	Anode	Anode	Anodo	<small>ANODE SO 160-160/1-200-200/1-SK 180-300-</small>	Anodo	43
7	8 733 304 999 0	Kappe	Protective cap	Capot de protection	Sigillo	Beschermkap	Capuchón protector	20
10	8 730 103 973 0	Dichtung	Washer	Joint	Guarnizione	Pakkingring	Junta	31
11	8 732 303 973 0	Isolierung	Insulation	Isolation	Isolamento	Isolatie	Aislamiento	26
24	8 712 000 034 0	Drehknopf	Rotary handle	Bouton de réglage	Manopola	Regelknop	Botón rotativo	12
25	8 737 208 991 0	Thermometer	Thermometer	Thermomètre	Termometro	<small>THERMOMETER SO...SK...-22-3Z - Z(W)... F</small>	Termómetro	37
26	8 713 403 008 0	Schraube (10x)	Screw	Vis (10x)	Vite (10x)	Schroef (10x)	Tornillo (10x)	11
27	2 916 030 006 0	Sicherungsscheibe (10x)	Retaining ring (10x)	Circlips (10x)	Rondella (10x)	<small>BORGRING UIT TTB 771900055P</small>	Arandela de seguridad (10x)	11
29	8 717 206 186 0	Temperaturregler	Flow thermostat	Thermostat	Thermostat	<small>AQUASTAAT MWISSELKONTAKT SO 120-160-200</small>	Regulador de temperatura	36
30	8 711 006 046 0	Klemmleiste 24V	Terminal strip 24V	Bornier 24V	Cablaggio 24V	Klemmenstrook 24V	Regleta de bornes 24V	08
31	8 714 401 396 0	Kabel	Cable	Faisceau	Cablaggio	Kabel	Cable	23
32	8 717 301 017 0	Entstörkondensator	ENTSTÖRKONDENSATOR	Condensateur	Condensatore	<small>CONDENSATOR VOOR AQUASTAAT 8 737 206 974</small>	Condensador filtro	14

For:



**Ersatzteilliste**  
**Spare parts list**  
**Liste des pièces de rechange**  
**Lista parti di ricambio**  
**Onderdelenlijst**  
**Lista de repuestos**

# TS200 - 7739300336

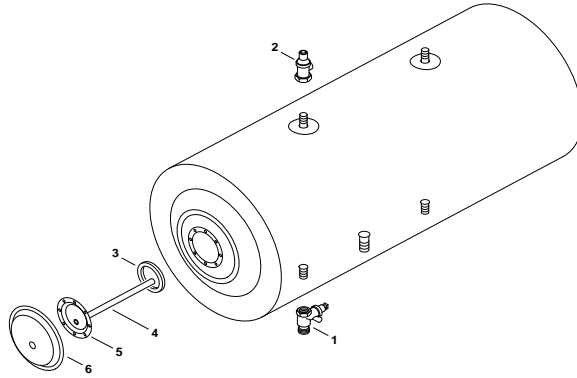

6720904386 AA/G

Pos	Bestell-Nr.	Bezeichnung	Description	Dénomination	Descrizione	Benaming	Descripción	PG
1	8 717 401 033 0	Sicherheitsventil	Safety relief valve	Soupape de sécurité	Valvola sicurezza	Veiligheidsklep	Válvula de sobrepresión	25
2	8 717 401 034 0	Sicherheitsventil	Safety relief valve	Soupape de sécurité	Valvola sicurezza	Veiligheidsklep	Válvula de sobrepresión	24
3	8 710 103 211 0	Dichtung	Washer	Joint	Guarnizione	Afdichting	Junta	22
4	8 719 928 411 0	Anode	Anode	Anode	Anodo	Anode	Anodo	25
5	8 715 503 559 0	Flansch	Connecting flange	Trappe de visite	Flangia	Aansluitflens	Brida de conexión	28
6	8 718 005 859 0	Deckel	Cover	Couvercle	Coperchio	Deksel	Tapa	26
	7 739 300 379	ETS2 Flansch f. Elektroheizstab	ETS2	ETS2	ETS2	ETS2	ETS2	

For: \_\_\_\_\_







Original Quality by  
Bosch Thermotechnik GmbH  
Sophienstraße 30-32  
D-35576 Wetzlar/Germany